

DAIHATSU

G202

Chassis

BRAKES

BRAKE PEDAL ADJUSTMENTS	BR- 2	REPLACEMENT OF BRAKE PAD	BR-20
BRAKE BOOSTER OPERATION CHECK	BR- 3	REPLACEMENT OF CALIPER RELATED	
ON THE VEHICLE CHECK	BR- 3	PARTS	BR-22
AIR BLEEDING OF BRAKE SYSTEM	BR- 4	REPLACEMENT OF CUP AND DUST	
ON THE VEHICLE CHECK	BR- 4	SEAL	BR-23
BRAKE PEDAL	BR- 5	INSTALLATION	BR-24
COMPONENTS	BR- 5	REAR DRUM BRAKES	BR-26
REMOVAL	BR- 5	COMPONENTS	BR-26
INSTALLATION	BR- 6	INSPECTION OF BRAKE SHOE &	
MASTER CYLINDER	BR- 7	DRUM	BR-27
COMPONENTS	BR- 7	REPLACEMENT OF WHEEL CYLINDER	BR-28
REMOVAL	BR- 8	REPLACEMENT OF BRAKE SHOE &	
DISASSEMBLY	BR- 8	BACKING PLATE	BR-29
REPLACEMENT	BR- 9	PARKING BRAKE	BR-32
INSTALLATION	BR-10	COMPONENTS	BR-32
BRAKE BOOSTER	BR-11	REMOVAL	BR-33
COMPONENTS	BR-11	INSTALLATION	BR-34
REMOVAL	BR-12	ADJUSTMENT OF WORKING TRAVEL	BR-34
DISASSEMBLY	BR-13	PROPORTIONING VALVE	BR-35
REPLACEMENT	BR-15	COMPONENTS	BR-35
ADJUSTMENT OF BOOSTER PUSH ROD		REPLACEMENT	BR-35
HEIGHT	BR-17	INSTALLATION	BR-35
INSTALLATION	BR-18	APPENDIX	BR-36
FRONT BRAKE	BR-19	SST	BR-36
COMPONENTS	BR-19	SERVICE SPECIFICATIONS	BR-37
INSPECTION OF BRAKE PAD WEAR	BR-19	TIGHTENING TORQUE	BR-38

G2BR0001-00000

NO. 9188

BRAKE PEDAL ADJUSTMENTS

1. Pedal height check

Measure the brake pedal height.

Specified Value: 151 - 156 mm

2. Pedal height adjustment

(1) Disconnect the connector from the stop lamp switch. Slacken the nut ① and turn the switch, until the pedal has a free travel.

(2) Slacken the nut ②. Turn the push rod ③ so as to adjust the pedal height. Lock the nut ②.

Tightening Torque: 12 - 17 N·m (120 - 180 kgf·cm)

(3) Turn the switch, until the pedal cushion comes in contact with the edge of the threaded portion of the stop lamp switch. Lock the nut ①.

Tightening Torque: 12 - 27 N·m (120 - 280 kgf·cm)

(4) Connect the connector of the stop lamp switch.

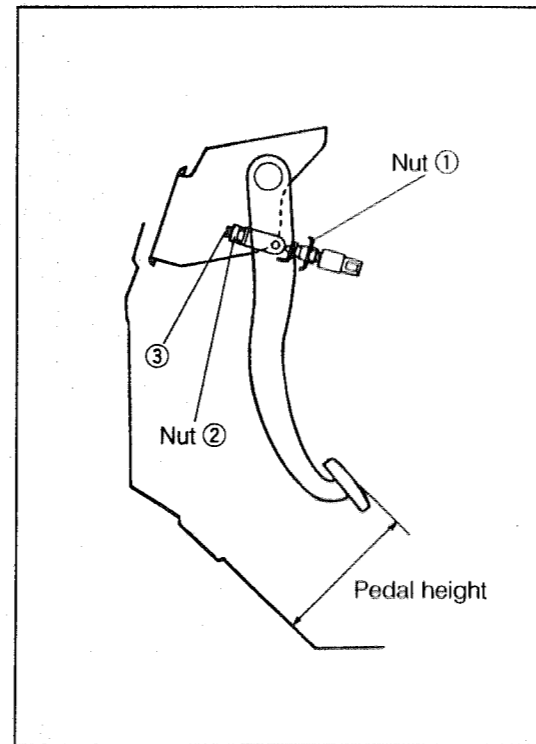

G2BR00002-00001

3. Pedal free play check

After stopping the engine, depress the brake pedal strongly several times so that no vacuum may remain in the brake booster. Measure the brake pedal free play by pushing the brake pedal lightly by hand. Here, the pedal free play means the distance from a point where the brake pedal is free to a point where you begin to feel a resistance.

Specified Value: 0.5 - 2 mm

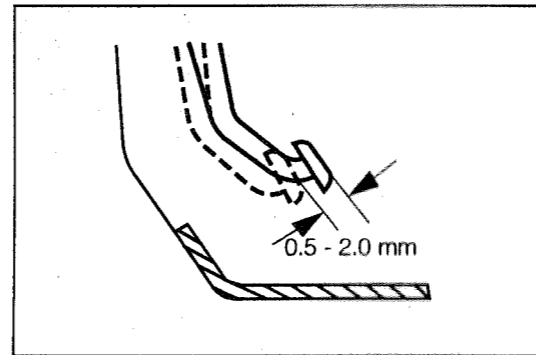

G2BR00003-00002

4. Pedal free travel adjustment

(1) Slacken the nut ②. Turn the push rod ③ so as to adjust the pedal free travel.

(2) Upon completion of the adjustment, ensure that the pedal height is proper and the stop lamp functions properly.

G2BR00004-00000

5. Pedal reserve travel check

With the engine running at the idling speed and with the parking brake lever in its returned state, depress the brake pedal with a pedal applying force of 300 N (30 kgf, 66 lb.). Measure the gap between the position where the depressed pedal stops and the floor panel.

Specified Value: Not less than 72 mm

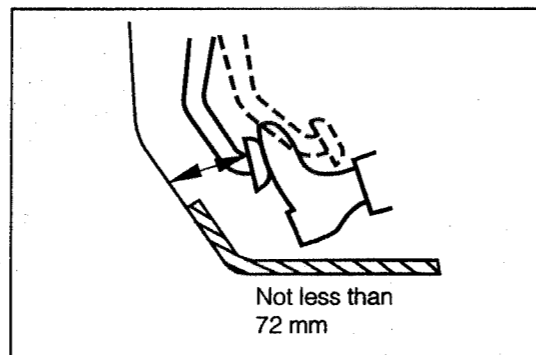

G2BR00005-00003

BRAKE BOOSTER OPERATION CHECK ON THE VEHICLE CHECK

1. Booster air-tight performance check

Start the engine. After a few minutes, stop the engine. Depress the brake pedal several times. If the position of the brake pedal rises progressively at the second and third applications, it indicates the brake booster is functioning properly.

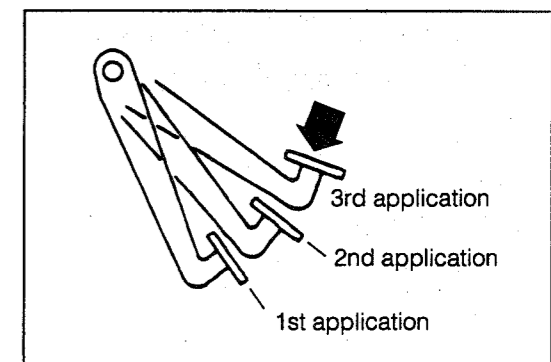

G2BR00006-00004

NOTE:

- Intervals of the pedal depressing applications should be at least five seconds.

2. Booster air-tight performance check under loaded condition

With the engine running, depress the brake pedal. While maintaining this condition, stop the engine. If the brake pedal height remains at the same level at least 30 seconds, it indicates that the booster is functioning properly.

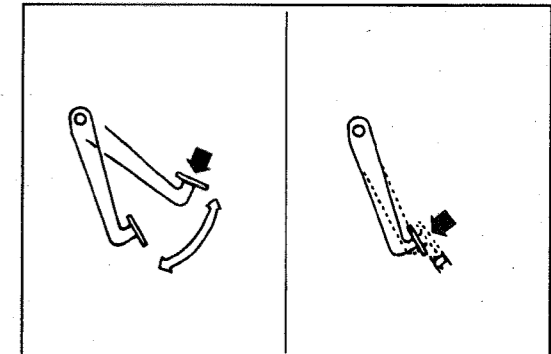

G2BR00007-00005

3. Booster operation check

With the engine stopped, depress the brake pedal several times, applying the same force at each brake application. Ensure that the brake pedal height will not vary at each brake application. Then, start the engine while depressing the brake pedal. If the brake pedal moves in slightly, it indicates that the booster is functioning properly.

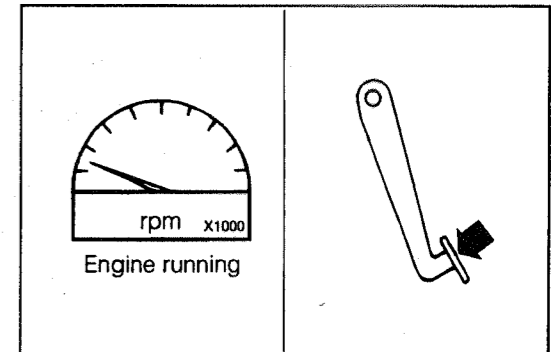

G2BR00008-00006

4. Booster air-tight performance check under loaded condition

Connect a negative pressure gauge to the booster, using a "T or Y" pipe joint.

With the engine running, depress the brake pedal with a pedal applying force of 200 N (20 kgf, 44 lb.). Stop the engine when the negative pressure exceeds 500 mmHg, stop the engine. Ensure that the negative pressure will not drop more than 25 mmHg for a period of 15 seconds following the stoppage of the engine.

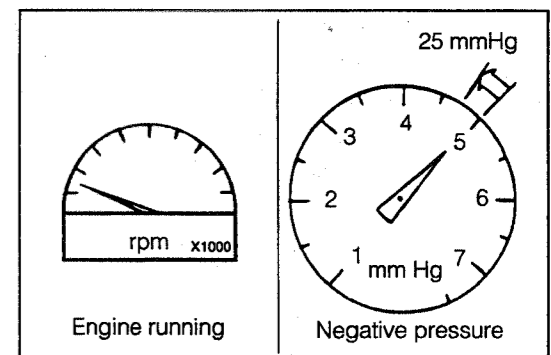

G2BR00009-00007

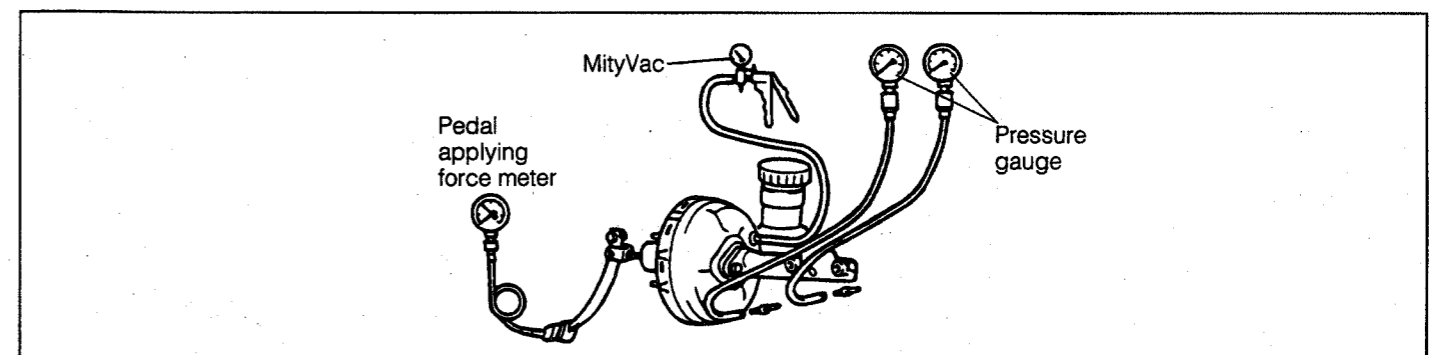

G2BR00010-00008

**AIR BLEEDING OF BRAKE SYSTEM
ON THE VEHICLE CHECK**

1. Filling brake fluid
Fill the brake master cylinder reservoir with the brake fluid.

NOTE:

- If the brake fluid is spilled inadvertently over the paint-finish surface of the vehicle, quickly wipe off the brake fluid.

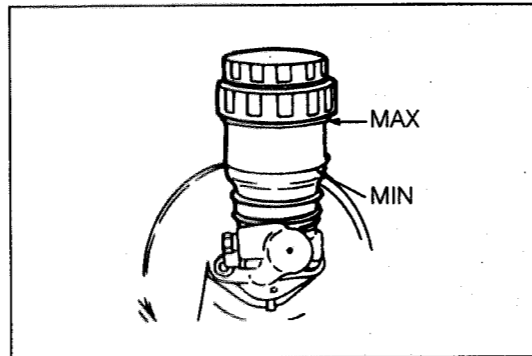

G2BR00011-00009

2. Connection of vinyl hose to bleeder plug of wheel cylinder

- (1) Submerge one end of a vinyl hose in a container filled with the brake fluid. Connect the other end of the vinyl hose to the wheel cylinder bleeder plug of the vehicle.
- (2) Start this air bleeding operation at the wheel cylinder which is located at the furthest point from the master cylinder.

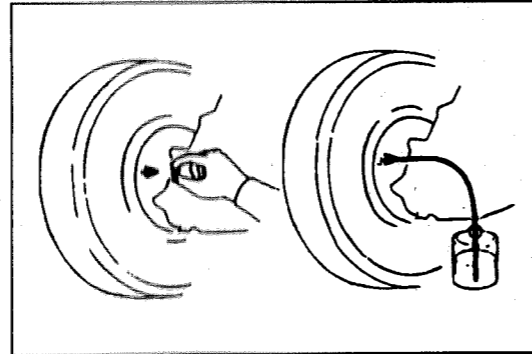

G2BR00012-00010

3. Air bleeding

- (1) Perform the operation by two persons. One person should depress the brake pedal slowly and hold it in a depressed state.
- (2) The other person slackens the bleeder plug 1/3 through 1/2 turn at a time. Be sure to tighten the bleeder plug before the hydraulic pressure ceases to exist in the cylinder.

Tightening Torque: 7 - 9 N·m (70 - 100 kgf·cm)

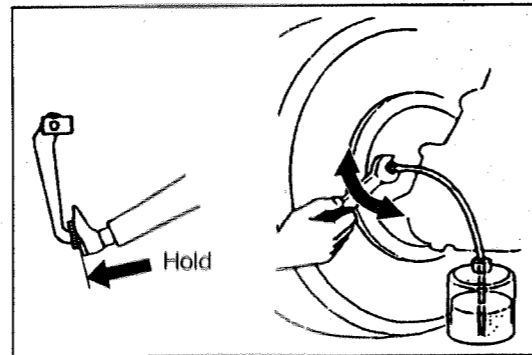

G2BR00013-00011

- (3) Repeat the steps (1) and (2) above, until you no longer observe bubbles in the fluid.

4. Checking of brake fluid leakage

Depress the brake pedal and ensure that each section of the pipe line exhibits no fluid leakage.

G2BR00014-00000

**BRAKE PEDAL
COMPONENTS**

□ : Tightening torque
Unit : N·m
★ : Non-reusable part

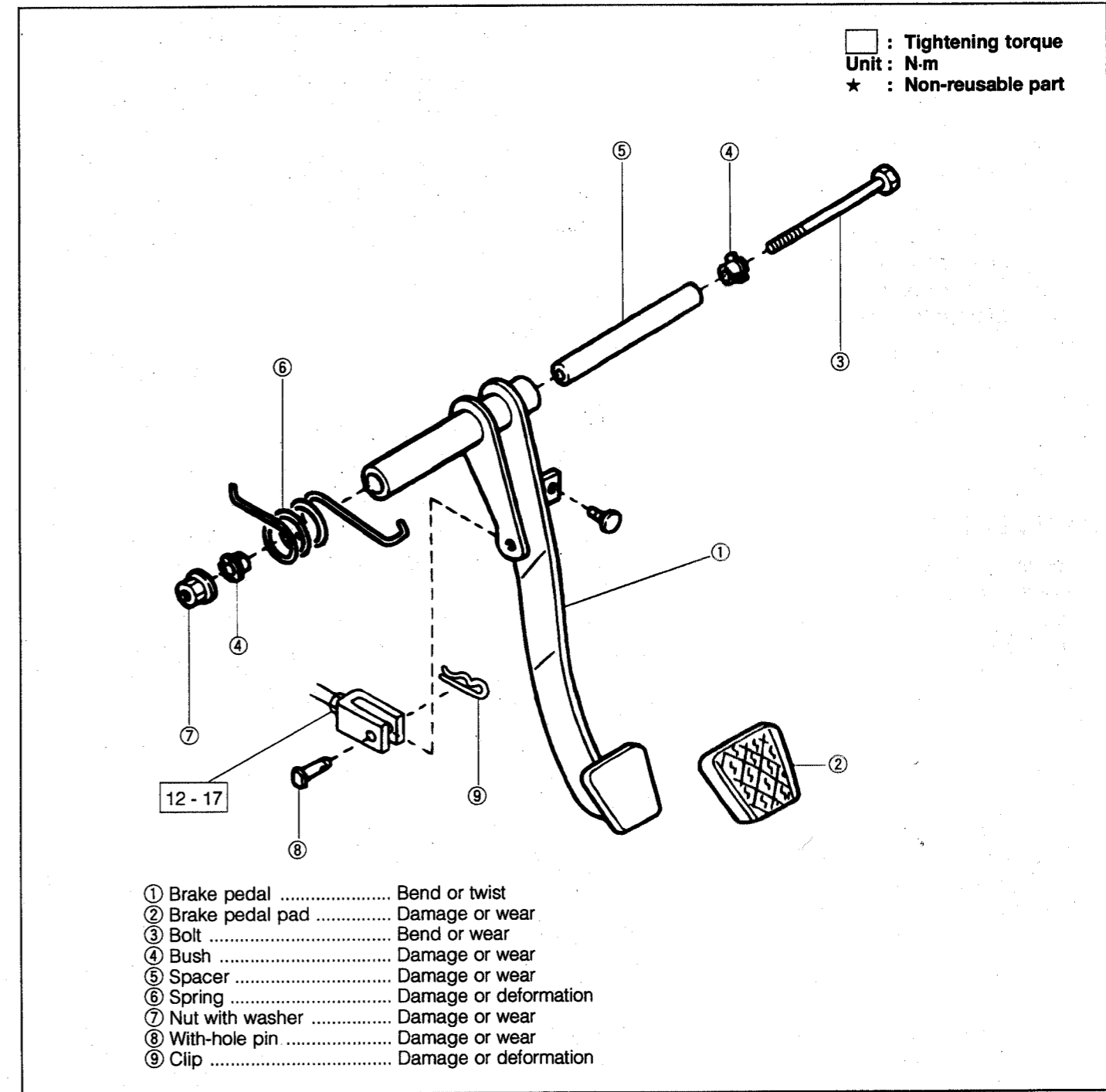

- | | | |
|-------------------|-------|-----------------------|
| ① Brake pedal | | Bend or twist |
| ② Brake pedal pad | | Damage or wear |
| ③ Bolt | | Bend or wear |
| ④ Bush | | Damage or wear |
| ⑤ Spacer | | Damage or wear |
| ⑥ Spring | | Damage or deformation |
| ⑦ Nut with washer | | Damage or wear |
| ⑧ With-hole pin | | Damage or wear |
| ⑨ Clip | | Damage or deformation |

G2BR00015-00012

REMOVAL

1. Remove the instrument panel finish lower panel.
2. Detach the stop lamp switch connector.
3. Disengage the clutch cable from the clutch pedal.
4. Remove the steering column with steering wheel from the pedal support assembly by removing the bolts and nuts.

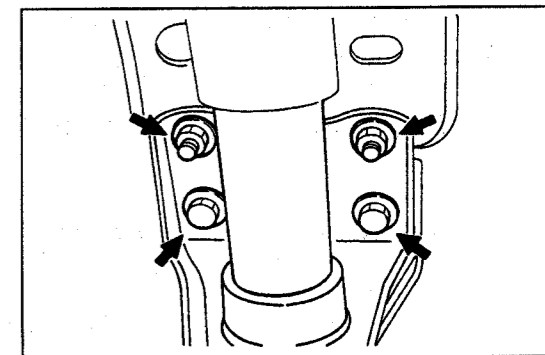

G2BR00016-00013

5. Remove the clip and the with-hole pin from the connecting section of the master cylinder push rod with the brake pedal.

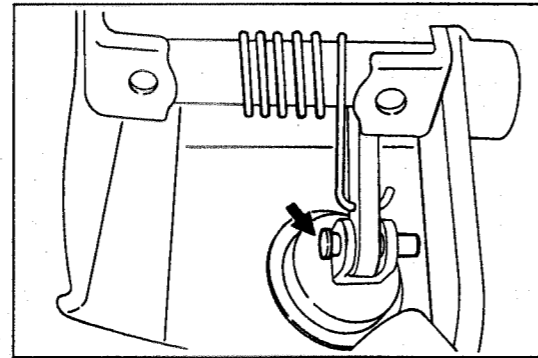

G2BR00017-00014

6. Remove the brake pedal by removing the bolt and nut from the brake pedal bracket.
 7. Remove the spring, bush, spacer, brake pedal pad and cushion from the brake pedal.

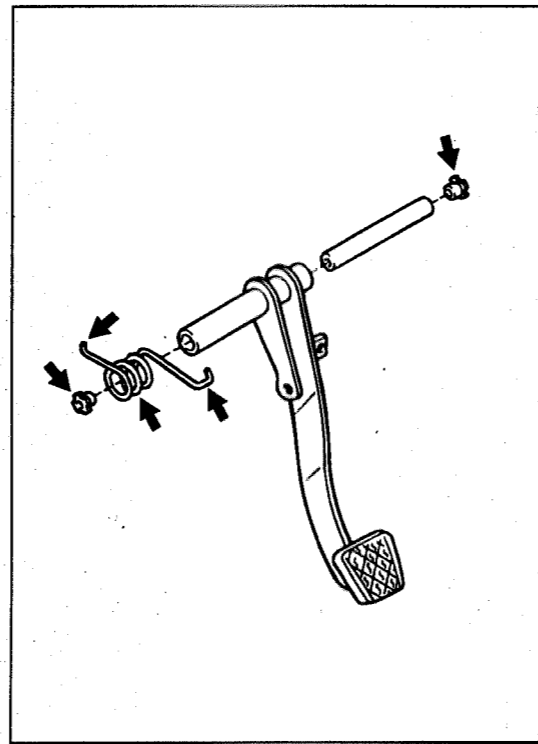

G2BR00018-00015

INSTALLATION

1. Install the cushion, brake pedal pad, spacer, bush and spring on the brake pedal.

NOTE:

- Be sure to apply specified grease to those points indicated by fingers in the right figure.
 Specified Grease: Lithium base multi-purpose grease

2. Install the brake pedal on the brake pedal bracket.
 3. Install the brake pedal attaching bolt and nut.
 Tightening Torque: 15 - 21 N·m

G2BR00019-00000

4. Install the with-hole pin and the clip on the connecting section of the master cylinder push rod with the brake pedal.
 Clevis Lock Nut Tightening Torque: 18 - 24 N·m

5. Install the stop lamp switch.
 6. Perform the check and adjustment of the brake pedal.
 Refer to page BR-2.

G2BR00020-00000

MASTER CYLINDER COMPONENTS

□ : Tightening torque
 Unit : N·m
 ★ : Non-reusable parts

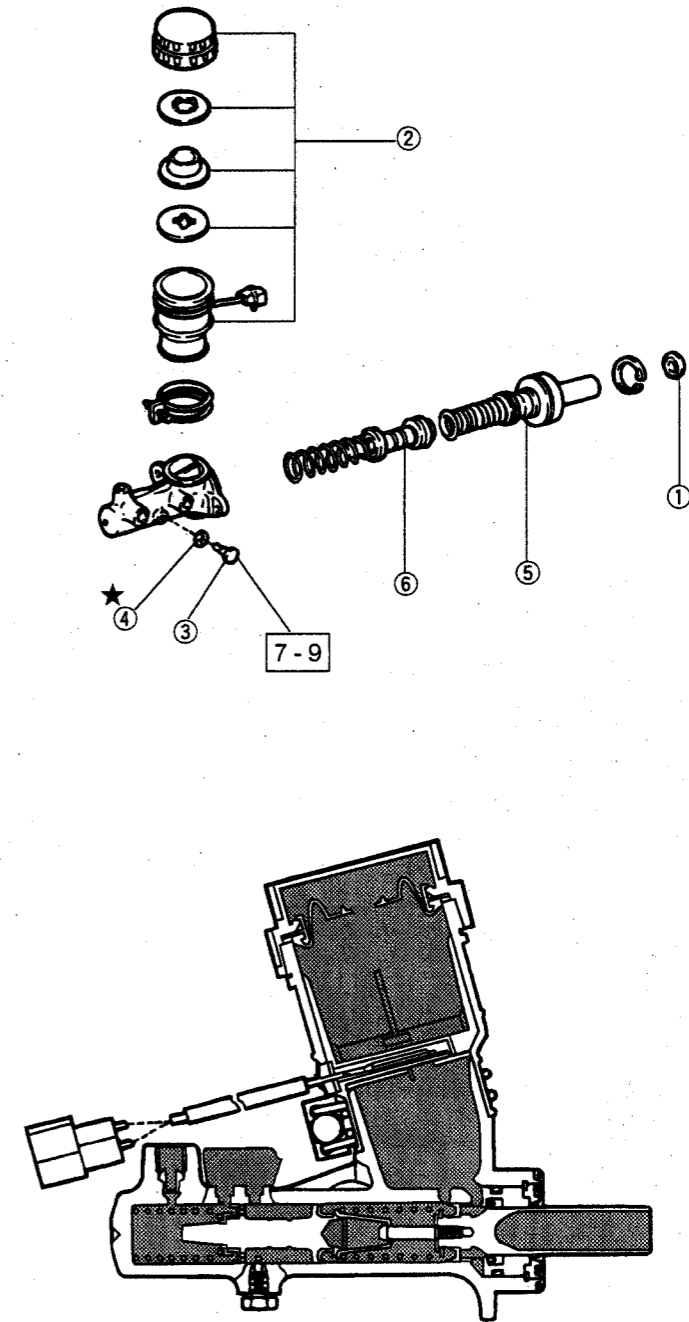

- ① Brake master cylinder piston seal
- ② Reservoir tank
- ③ Set bolt
- ④ Gasket
- ⑤ Master cylinder piston assembly No. 1
- ⑥ Master cylinder piston assembly No. 2

REMOVAL

1. Disconnect the connector of the brake fluid level switch.
2. Drain the brake fluid.
3. Disconnect the brake tubes from the master cylinder.
4. Remove the master cylinder and gasket.
5. Remove the master cylinder and gasket from the brake booster.

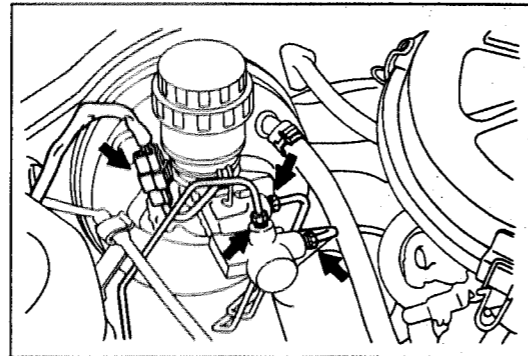

G2BR0022-00201

DISASSEMBLY

1. Removal of reservoir tank
Heat the clump section of the reservoir. Remove the reservoir by removing the clump.

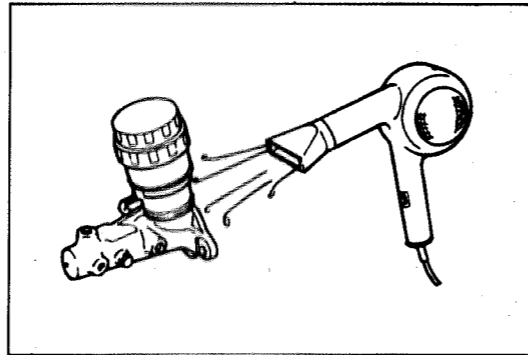

G2BR0023-00018

2. Remove the set bolt and gasket while the pistons are being pushed fully by means of a suitable bar.

NOTE:

- Measure the master cylinder piston height, before removing the piston. Refer to page BR-10.
- During the removal, be sure to push the piston slowly so as to prevent the brake fluid from splashing.

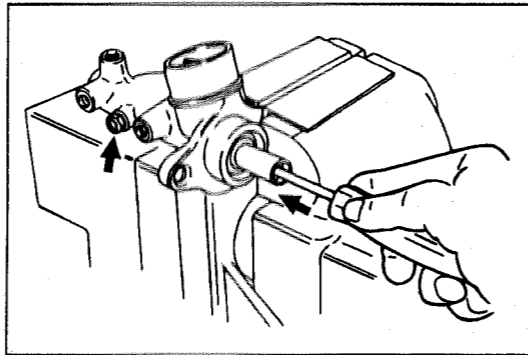

G2BR0025-00020

3. Using a snap ring pliers, detach the snap ring while the pistons are being pushed by means of a suitable bar.

4. Remove the pistons No. 1 from the master cylinder.

NOTE:

- Remove the piston straight, being very careful not to scratch the cylinder bore.

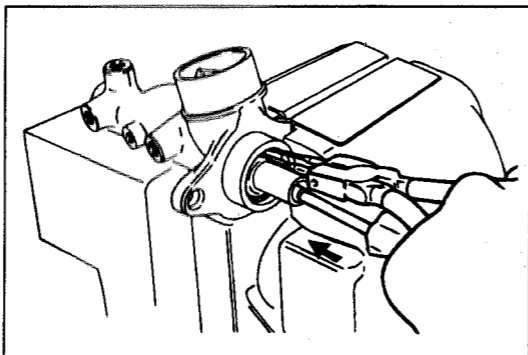

G2BR0026-00021

5. Remove the piston No. 2 by lightly tapping the flange surface.

NOTE:

- Remove the piston straight, being very careful not to scratch the cylinder bore.

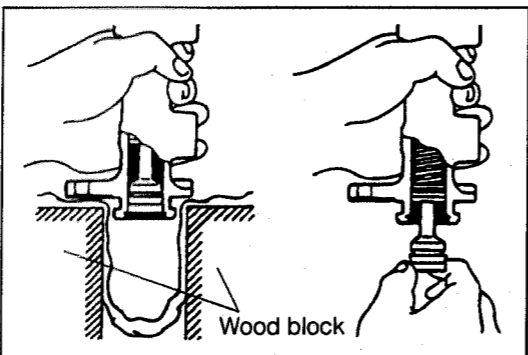

G2BR0027-00022

REPLACEMENT

1. Preparation of following new parts (Repair kit)
 - Brake master cylinder piston seal
 - Gasket
 - Brake master cylinder piston assembly No. 1
 - Brake master cylinder piston assembly No. 2

NOTE:

- Apply rubber grease to those points indicated in the illustration.

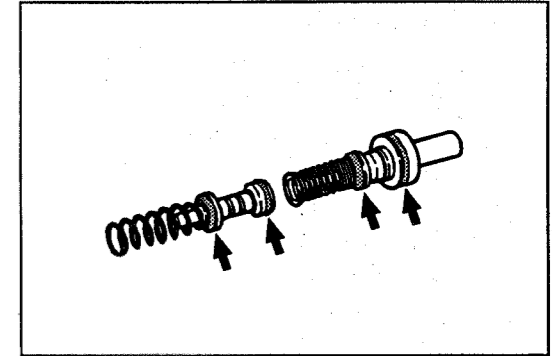

G2BR0028-00202

2. With the pistons in their fully pushed in state, install a new snap ring.

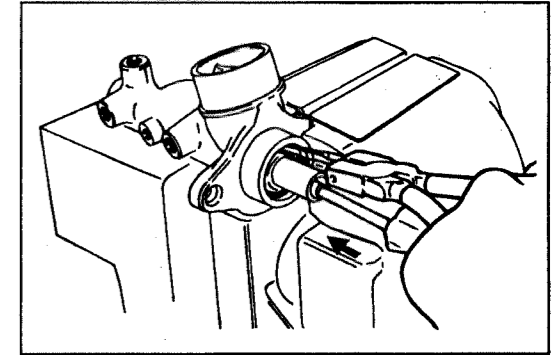

G2BR0029-00021

3. While pushing the piston fully with a screwdriver, assemble the set bolt with a new gasket.

Tightening Torque: 7 - 11 N·m (70 - 110 kgf·cm)

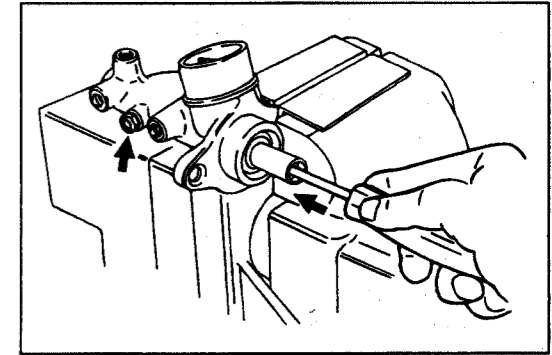

G2BR0030-00020

4. Installation of reservoir tank

- (1) Heat the clump section of the reservoir. Install the reservoir tank to the master cylinder.
- (2) Tighten the clump.

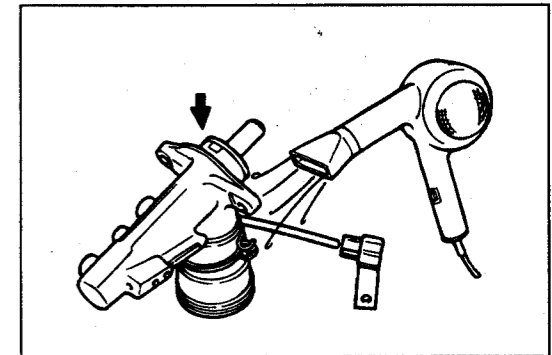

G2BR0031-00026

INSTALLATION

1. Check the clearance between the master cylinder and the brake booster push rod.

NOTE:

- In case where the master cylinder only is replaced, be sure to measure the master cylinder height before the replacement, using the SST. After installing the new master cylinder piston assembly, adjust the push rod height of the booster to the same clearance as that before the replacement.

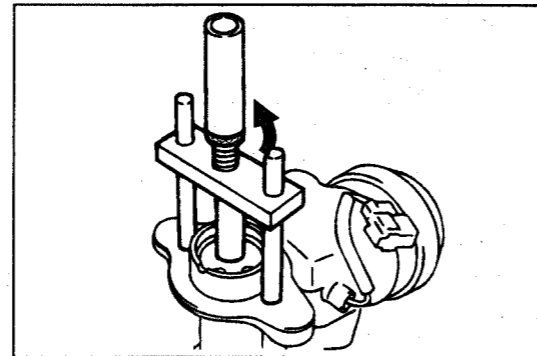

G2BR00033-00028

2. With a new gasket interposed, install the master cylinder, using the two nuts.

Tightening Torque: 12 - 17 N·m (120 - 184 kgf·cm)

NOTE:

- The master cylinder attaching nut at the right side (L.H.D. vehicle), as viewed toward the vehicle, should be used to tighten the bracket of the connector of the fluid level switch, too. As the R.H.D. vehicle, the bracket that are located at opposite side.

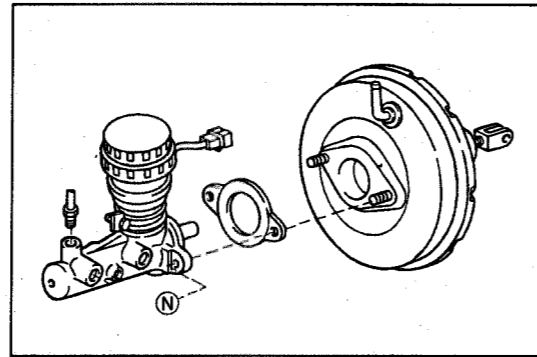

G2BR00034-00029

3. Connect the brake tubes.

- (1) Temporarily connect the three brake tubes to the master cylinder by hands.

- (2) Tighten the brake tubes to the master cylinder.
Tightening Torque: 13 - 17 N·m (133 - 184 kgf·cm)

G2BR00035-00000

4. Connect the level switch connector.
5. Fill the brake fluid.
6. Perform air bleeding for the brake system.
7. Check the brake system for brake fluid leakage.
8. Perform the checks and adjustments for the brake pedal height.

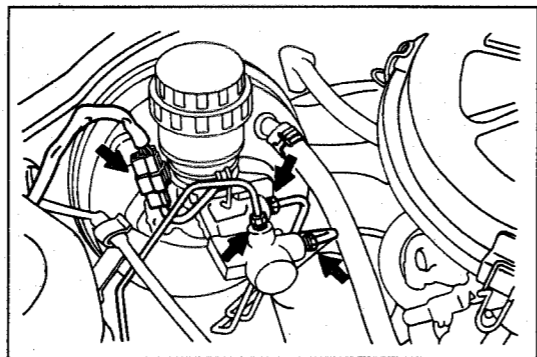

G2BR00036-00201

BRAKE BOOSTER COMPONENTS

□ : Tightening torque
Unit : N·m
★ : Non-reusable part

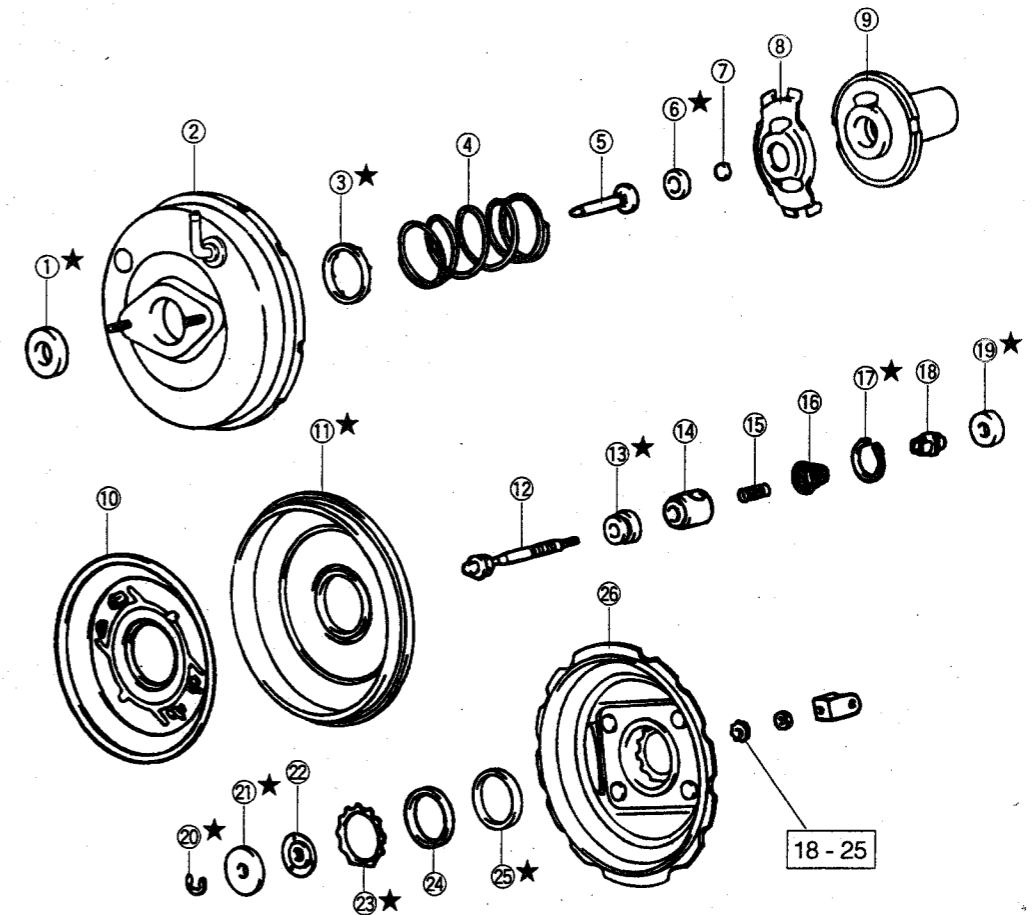

- ① Master cylinder piston seal
- ② Booster body
- ③ Spring retainer
- ④ Booster spring
- ⑤ Booster piston rod
- ⑥ Reaction disc
- ⑦ Air valve seal
- ⑧ Set cover
- ⑨ Valve body
- ⑩ Booster plate
- ⑪ Diaphragm
- ⑫ Booster with rod, valve subassembly
- ⑬ Poppet valve

- ⑭ Air valve spring retainer
- ⑮ Control valve spring
- ⑯ Valve spring
- ⑰ Piston return spring retainer
- ⑱ Control valve spring retainer
- ⑲ Element A
- ⑳ E-ring
- ㉑ Element B
- ㉒ Adjustment nut
- ㉓ Booster push rod seal retainer
- ㉔ Valve ring
- ㉕ Piston seal
- ㉖ Booster housing

G2BR00037-00031

REMOVAL

1. Remove the instrument finish lower panel.
 2. Disconnect the connectors for the multi-use lever switch and key switch.
 3. Remove the steering column assembly from the reinforcement, by removing the two nuts and four bolts.
 4. Remove the clip and the with-hole pin at the brake pedal. Separate the master cylinder push rod clevis and from the brake pedal.
 5. Remove the attaching nuts of the booster.
 6. Disconnect the connector of the brake fluid level switch.
 7. Drain the brake fluid.
 8. Disconnect the brake pipes from the master cylinder.
 9. Remove the master cylinder and gasket.
 10. Disconnect the vacuum hose.
- NOTE:**
- If the brake fluid is spilled inadvertently over the paint finish surface of the vehicle, quickly wipe off the brake fluid.
11. Remove the ignition coil. (For L.H.D. vehicle)
 - Remove the air cleaner. (For L.H.D. vehicle)

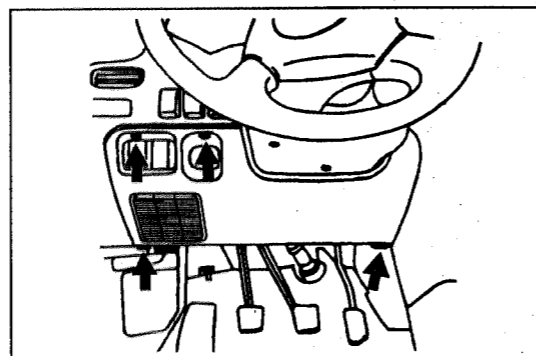

G2BR00038-00032

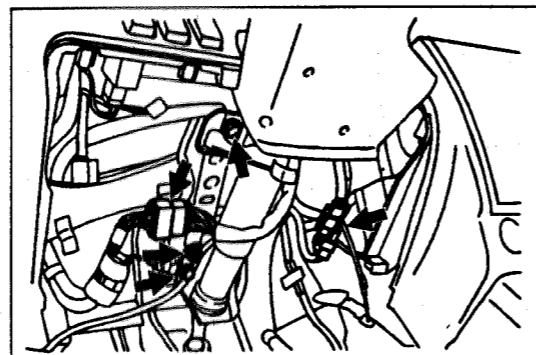

G2BR00039-00033

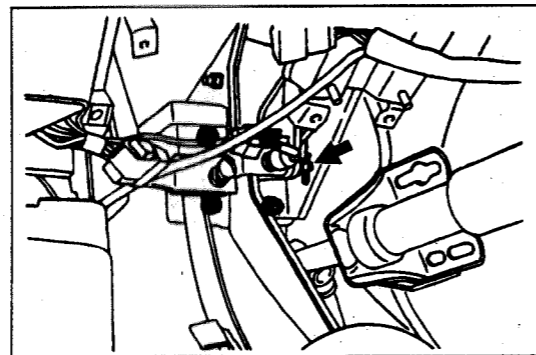

G2BR00040-00034

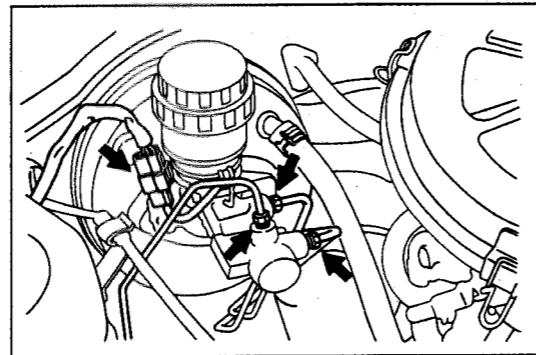

G2BR00041-00201

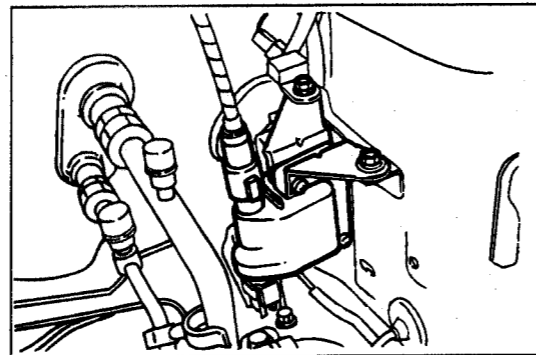

G2BR00042-00205

12. Removal of clutch cable support bracket. (For L.H.D. vehicle)
 - (1) Remove the battery and the engine coolant reservoir tank.
 - (2) Slacken the adjusting ring. Disconnect the clutch cable from the transmission side.
 - (3) Remove the clutch cable support bracket.
13. Remove the brake booster assembly and gasket from the vehicle.

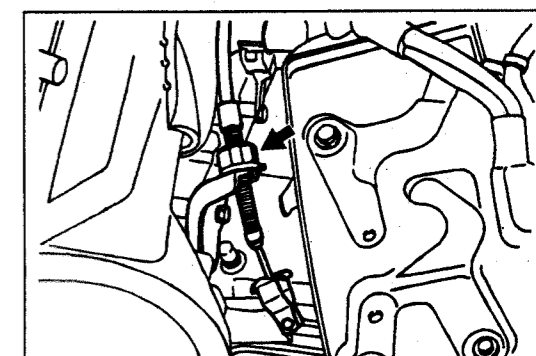

G2BR00043-00037

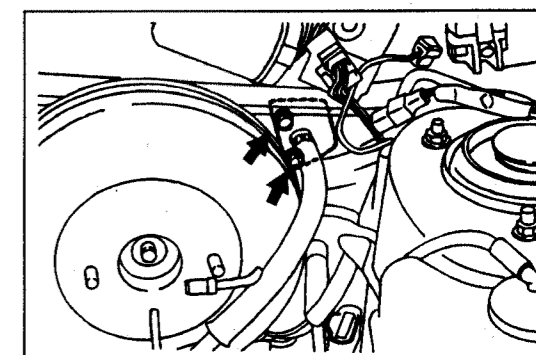

G2BR00044-00038

DISASSEMBLY

1. Remove the master cylinder push rod clevis and lock nut.
2. Secure the brake booster on the following SST.
 - SST: 09753-87701-000

NOTE:

- Be certain to evenly tighten the SST nuts at the right and left side.
- Put mate marks on the booster body and booster housing.

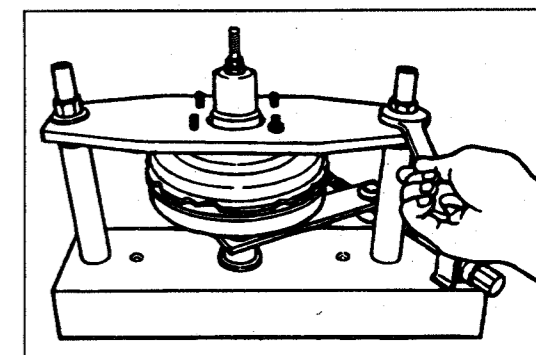

G2BR00045-00039

3. Separate the booster housing from the booster body, using the cut-out section provided at the side of the booster body, by means of turning the SST screw clockwise so as to disengage the booster housing from the booster body.

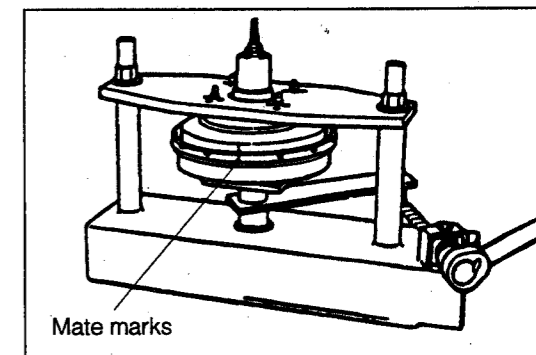

Mate marks

G2BR00046-00040

4. Detach the brake booster from the SST.

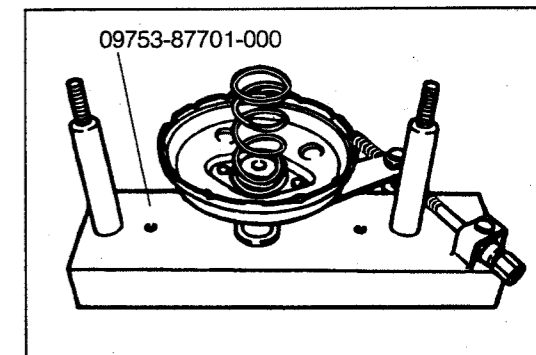

09753-87701-000

G2BR00047-00041

5. Disassembly of booster

- (1) Remove the booster spring and spring retainer.
- (2) Disassembly of set cover as following
 - (a) Slide the claw section of the set cover using a screwdriver.
 - (b) Disassemble the set cover from booster plate.

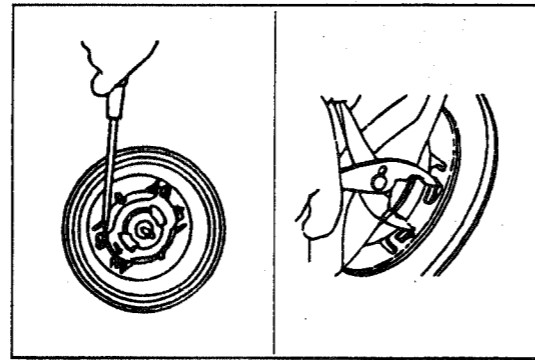

G2BR00048-00042

(3) Removal of following parts

- (a) Booster piston rod
- (b) Reaction disc
- (c) Air valve seal
- (d) Valve body assembly
- (e) Booster plate
- (f) Diaphragm

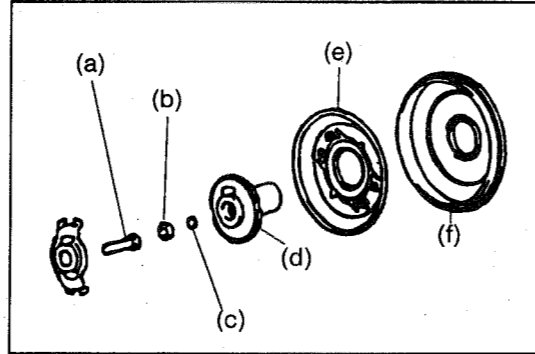

G2BR00049-00043

(4) Removal of following parts

- (a) Lock nut
- (b) Adjusting nut
- (c) Element B

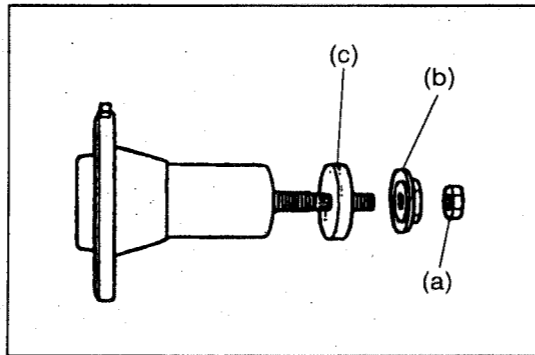

G2BR00050-00044

(5) Disassembly of air valve spring retainer in conjunction with the following parts from the valve body as following.

NOTE:

- Remove the piston return spring retainer. Then, push the valve body in combination with the booster piston rod by hands as indicated in the illustration.

- (a) Piston return spring retainer
- (b) E-ring
- (c) Element A
- (d) Control valve spring retainer
- (e) Valve spring
- (f) Control valve spring
- (g) Air valve spring retainer
- (h) Poppet valve
- (i) Booster valve subassembly with rod

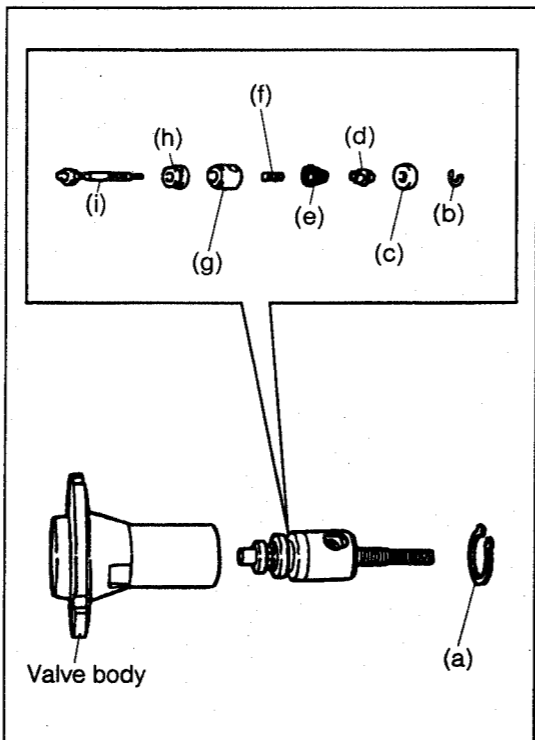

G2BR00051-00045

REPLACEMENT

1. Prepare following new parts.

- Master cylinder piston seal
- Spring retainer
- Reaction disc
- Diaphragm
- Poppet valve
- Element A
- Piston return spring retainer
- E-ring
- Element B
- Booster push rod seal retainer
- Piston seal

2. Assembly of air valve spring retainer

- (1) Assemble a new poppet valve and the valve spring retainer.
- (2) Install the booster valve subassembly with rod into the valve spring retainer.
- (3) Install the control valve spring and valve spring into the rod.

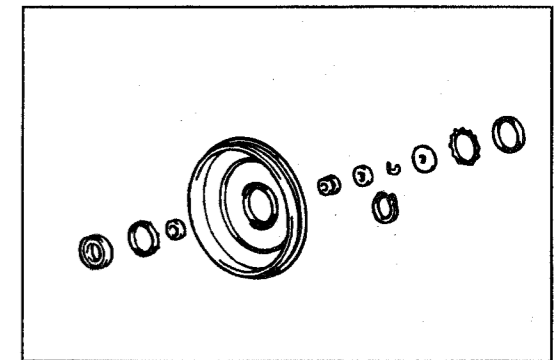

G2BR00052-00046

(4) Assemble a new element A and the new control valve spring retainer.

- (5) Install them into the rod.
- (6) Attach the new E-ring in place of the rod while pushing the control valve spring retainer with finger. Then, install the E-ring with a pliers.

NOTE:

- Make sure to installation direction of the control valve spring retainer that its long side faces spring side and short faces element side.

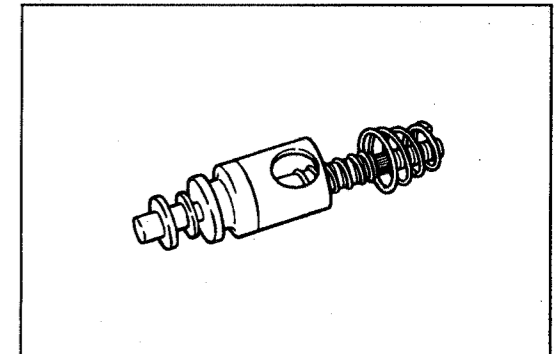

G2BR00053-00047

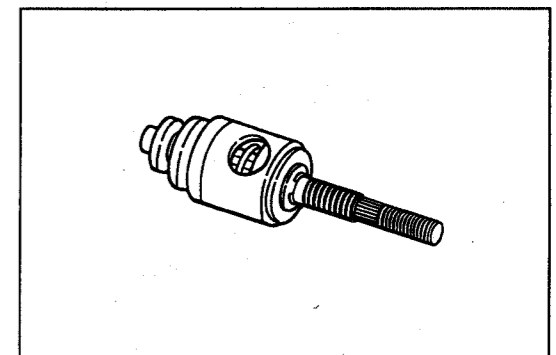

G2BR00054-00048

3. Assembly of valve body

- (1) Apply silicon grease around the poppet valve. Then, install them into the valve body.
- (2) Place the piston return spring retainer into the valve body with a snap ring pliers.

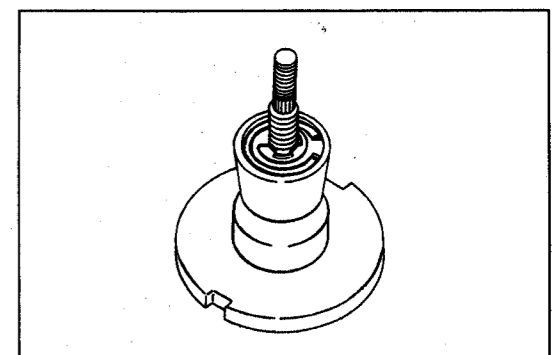

G2BR00055-00049

- (3) Install a new element ③, adjusting nut ② and lock nut ① into the rod as temporarily.

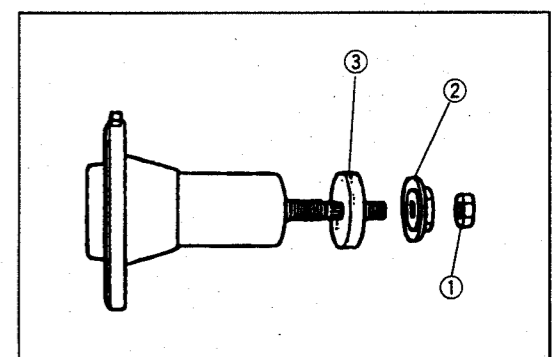

G2BR00056-00050

4. Apply silicone grease to the inner and outer periphery of the piston seal ⑫ as well as to the inside of the groove. Insert the piston seal into the booster housing. Also, insert the valve ring ⑭. Secure them with the booster push rod seal retainer ⑬.

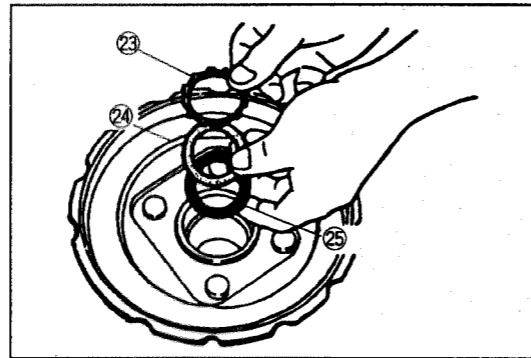

G2BR00057-00051

5. Assemble the new diaphragm ⑩ and booster plate ⑨. Then, attach them into the booster housing.
6. Apply silicone grease to the outer periphery of the valve body. Then, assemble them into the booster housing.

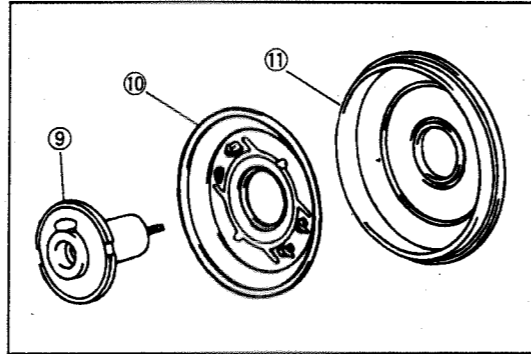

G2BR00058-00052

7. Installation of following parts in the valve body.

- (a) Reaction plate ⑦
(b) New reaction disc ⑥
(c) Booster piston rod ⑤

NOTE:

- Install the reaction plate in such a direction that its flat side faces upward.
- Apply silicone grease to the reaction disc.

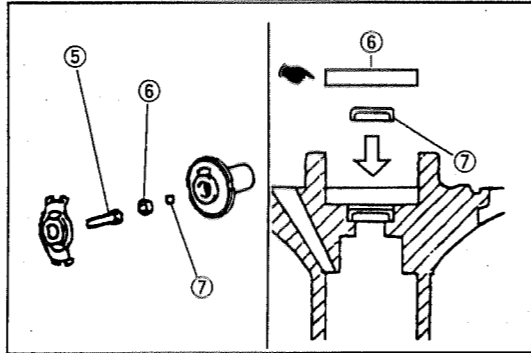

G2BR00059-00053

8. Installation of set cover ① as follows:

- (1) Temporarily install the set cover on the booster plate.

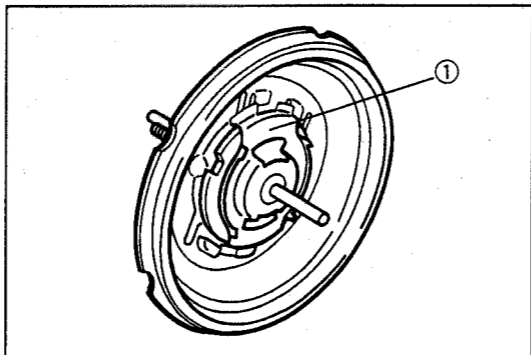

G2BR00060-00054

- (2) Assemble the set cover by pinching the joint section of the booster plate with the claw section of the set cover, using a pliers.

- (3) Slide the claw section of the set cover using a screwdriver, until it touched the stopper.

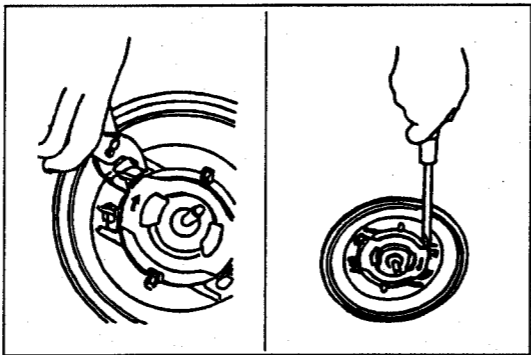

G2BR00061-00055

9. Assembly of the booster body and booster housing

- (1) Place the booster body in the following SST.
SST: 09753-87701-000

- (2) place the new spring retainer and booster piston return spring on the booster body.

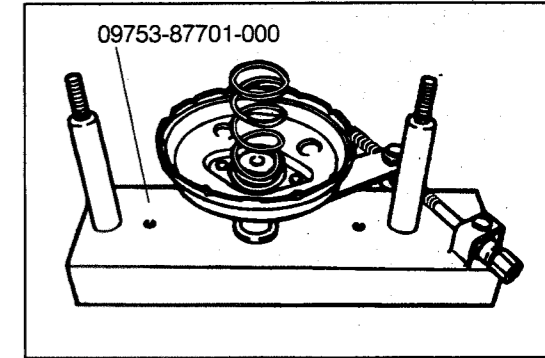

G2BR00062-00041

10. Align the cut-out section of the booster body with projected section. Join the booster body with the booster housing in the SST and tighten the SST nuts until booster housing and booster body will be contacted.

NOTE:

- Be certain to evenly tighten the SST nuts at the right and left sides. Be careful no to tighten excessively.
- Make sure that matching marks placed near each other.

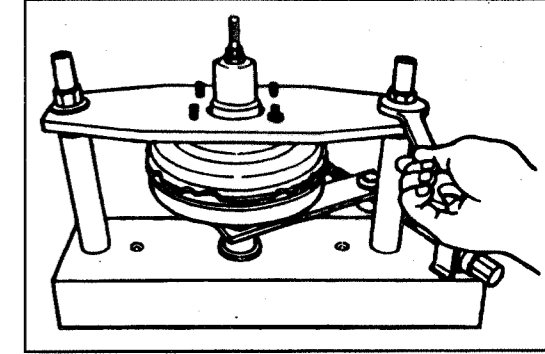

G2BR00063-00039

11. Turn the SST screw so that the mating marks ① may be lined up.

NOTE:

- If the force required for turning is great, Check the diaphragm pinched. Then, apply a small amount of silicone grease to the portion where the booster body is making contact with the booster housing.

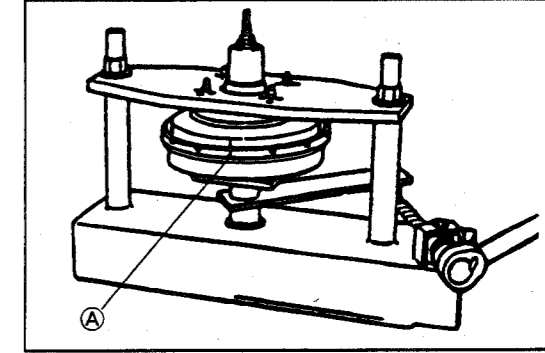

G2BR00064-00058

12. Remove the SST nuts and remove the brake booster from the SST.

ADJUSTMENT OF BOOSTER PUSH ROD HEIGHT

1. Set the SST in such a way that the SST rod makes a light contact with the piston of the master cylinder by turning the SST rod, as indicated in the illustration.

SST: 09737-87002-000

NOTE:

- Be sure to carry out this adjustment with the gasket attached in position of the master cylinder.

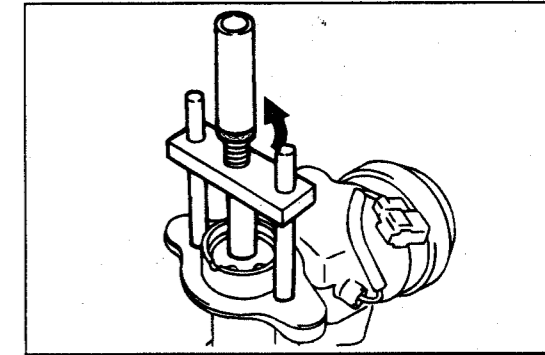

G2BR00066-00028

2. Turn over the SST and set the SST on the booster as indicated in the illustration.

3. Apply vacuum of 66 kPa (500 mmHg) on the booster housing, using the MityVac.

4. Measure the rod height by turning the SST rod so that it may make contact with the booster piston rod and SST rod.

NOTE:

- When booster piston rod will over contact with SST rod, turn the SST it self.
- The SST rod employs a screw of 1 mm pitch. Therefore, one turn of the rod moves 1 mm.

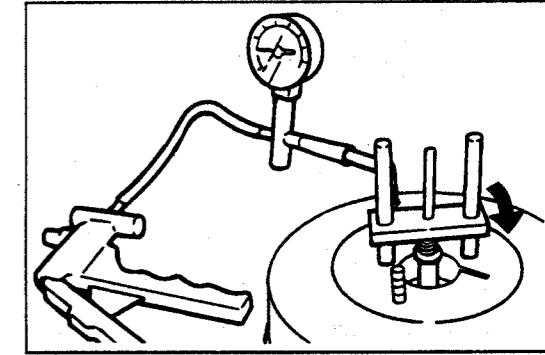

G2BR00067-00061

- Adjust the height of the booster piston rod by turning the adjusting nut provided at the booster valve with rod, until SST rod and booster piston rod will contact so that the clearance of booster piston rod and master cylinder piston may become the specified value. Then, tighten the booster valve with rod rock nut.

Specified Value: 0.1 - 0.3 mm
 Tightening Torque: 18 - 24 N·m
 (180 - 250 kgf·cm)

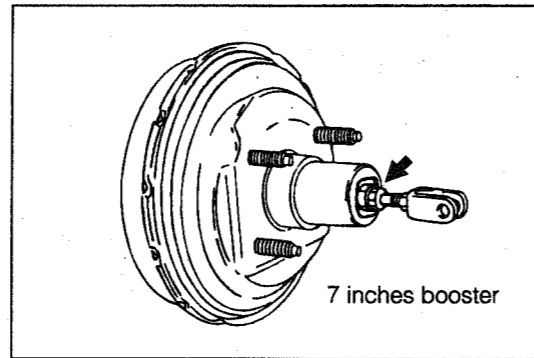

INSTALLATION

- Install the brake booster on the body with a new gasket interposed.

Tightening Torque: 10 - 15 N·m (100 - 160 kgf·cm)

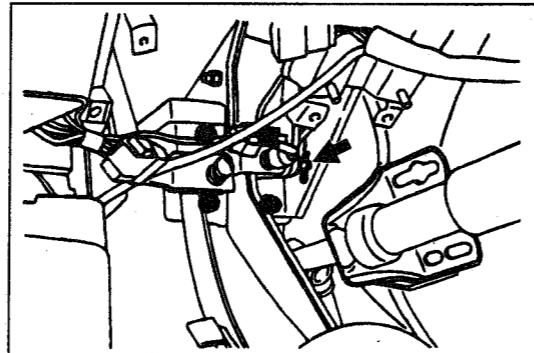

- Install the steering column assembly to the reinforcement.
- Connect the connectors for the multi-use lever switch and key switch.

Tightening Torque:
 Bolt: 15 - 21 N·m (150 - 220 kgf·cm)
 Nut: 10 - 15 N·m (100 - 160 kgf·cm)

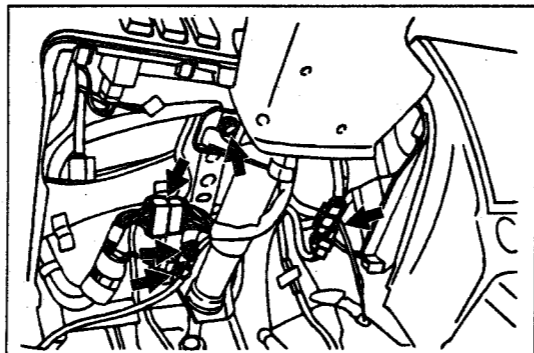

- Install the instrument finish lower panel.

- Install the clutch cable support bracket to the body. (For L.H.D. vehicle)
 Connect the clutch cable.
 Adjust the clutch pedal free play and reserve travel.

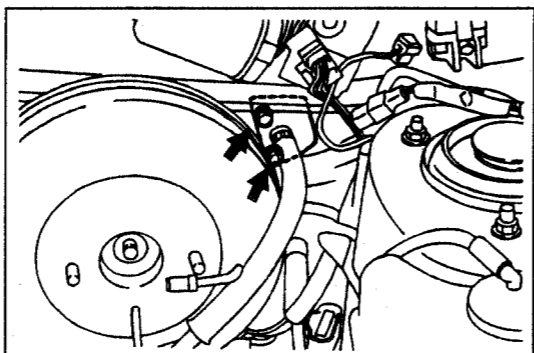

- Install the air cleaner and the ignition coil. (For L.H.D. vehicle)

- Connect the new vacuum hose between the intake manifold and the booster.

- Install the master cylinder with a new gasket interposed.
 Engage the master cylinder and booster with nuts.

Tightening Torque: 12.7 N·m (130 kgf·cm)

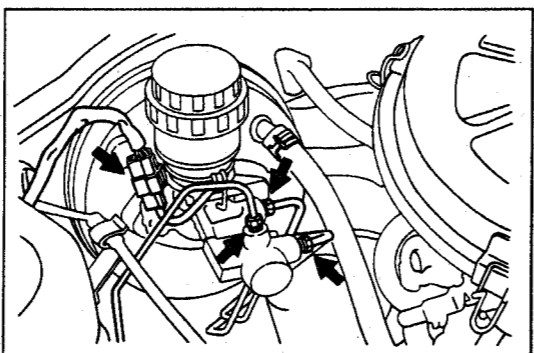

- Connect the brake tube to the master cylinder.

Tightening Torque: 13 - 17 N·m (130 - 180 kgf·cm)

- Connect the terminal of the brake fluid level switch.

- Perform the air bleeding for brake system.

Refer to page BR-4.

FRONT BRAKE COMPONENTS

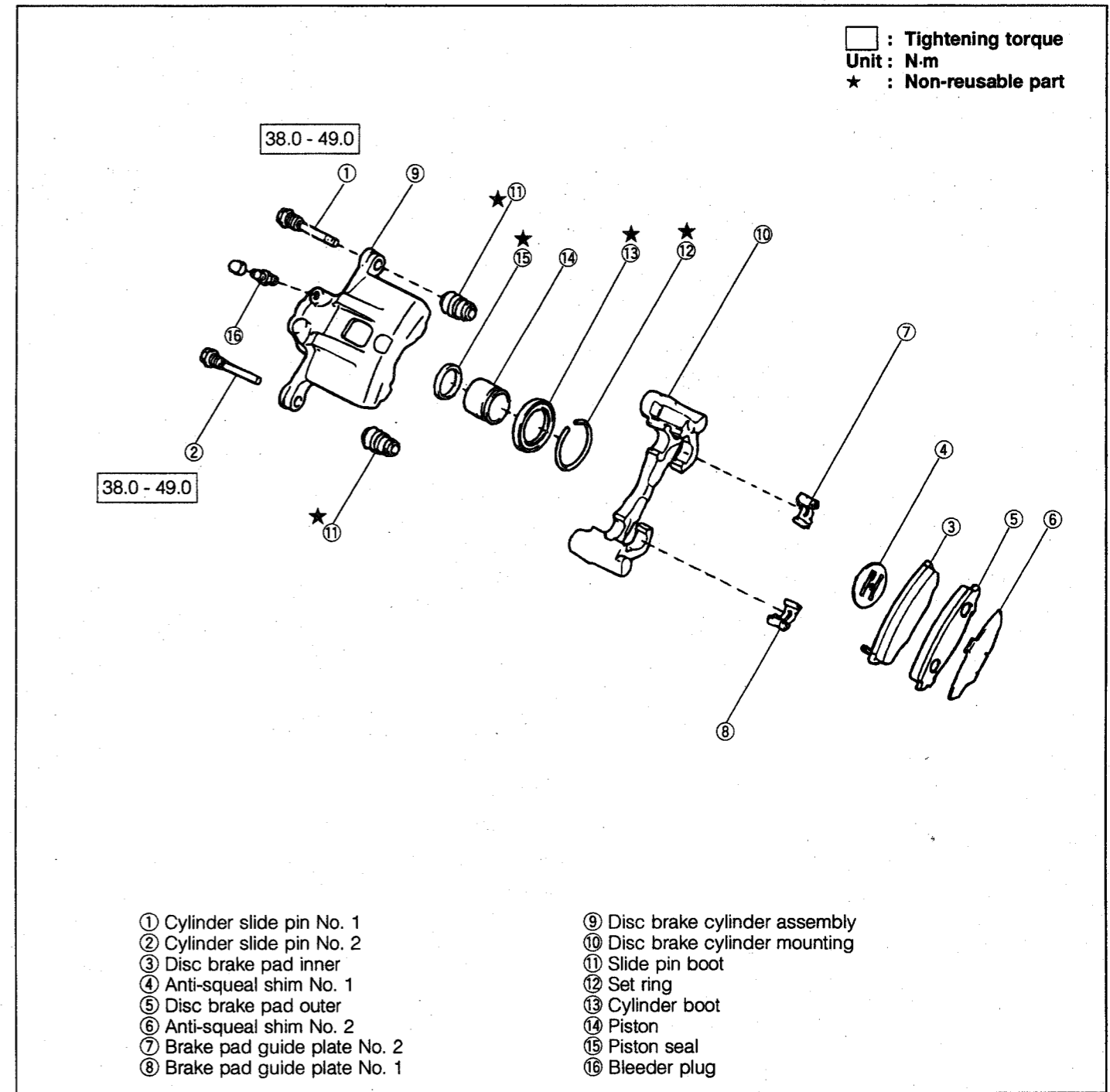

INSPECTION OF BRAKE PAD WEAR

- Jack up the vehicle with safety stands.
- Check that the front wheel bearing exhibits no excessive looseness.
 Refer to page FS-4.
- Remove the front wheel.
- Inspect the pad thickness through the inspection hole (A) provided in the disc brake caliper.

Specified Thickness: 10 mm
 Minimum Thickness: 1 mm

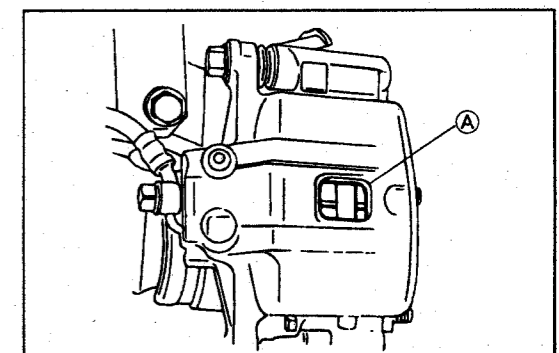

REPLACEMENT OF BRAKE PAD

DISASSEMBLY

1. Remove the brake hose bracket from the shock absorber.
2. Remove the cylinder slide pin No. 1.

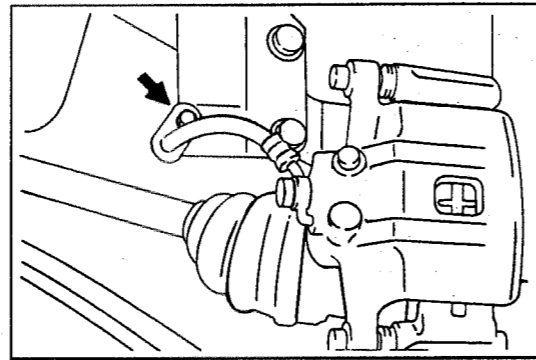

G2BR00076-00070

3. Turn the cylinder assembly upward so as to remove the brake pad.

NOTE:

- Be sure to carry out the pad replacement operation for one wheel at a time, for there is a possibility that the piston at the opposite side may be jumped out.
- Suspend the cylinder assembly with suitable a string.

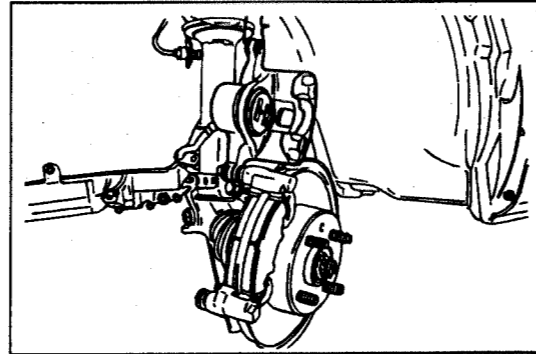

G2BR00077-00071

4. Detach the following parts from the disc brake cylinder mounting.

- Disk brake pad ②
- Anti-squeal shim No. 1 ③ and No. 2 ⑤
- Brake pad guide plate No. 1 ⑥ and No. 2 ⑦

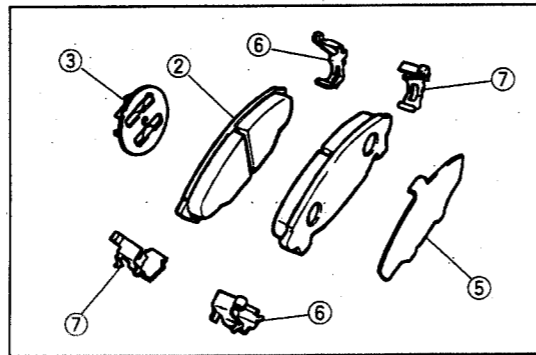

G2BR00078-00072

INSPECTION

1. Inspect the disc brake pad thickness for uneven wear and damage.
2. Inspect the disc rotor thickness.

Specified Thickness: 11 mm for solid disc
18 mm for ventilated disc

Minimum Thickness: 10 mm for solid disc
17 mm for ventilated disc

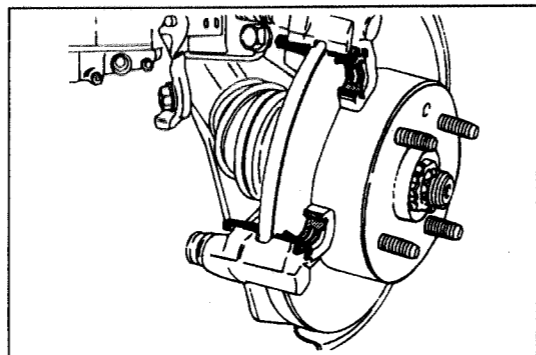

G2BR00079-00073

3. Inspection of disc rotor runout

- (1) Perform the measurement with the disc in the attached condition on the hub.

(The disc should be tightened securely by means of the hub nuts.)

- (2) Ensure that the wheel bearings exhibit no looseness.
- (3) Perform the runout measurement at a point 8 mm inward from the outer edge.

Maximum Disc Runout: 0.10 mm

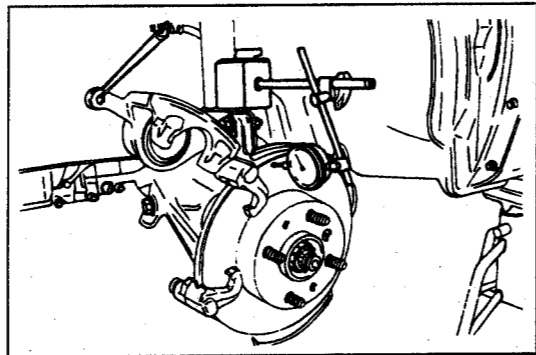

G2BR00080-00074

- (4) If the runout exceeds the allowable limit, change the installation position of the disc relative to the hub. Carry out the measurement again.

- (5) If the runout still exceeds the allowable limit even after the phase of the installation position has been changed, replace the disc.

NOTE:

- Replace the disc rotor, as required.
- Refer to page FS-10.

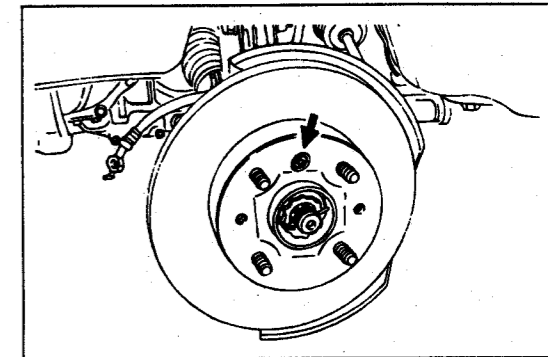

G2BR00081-00075

REPLACEMENT

1. Place the anti-squall shim No. 1 on the cylinder.
2. Place the anti-squall shim No. 2 on the disc brake pad outer.

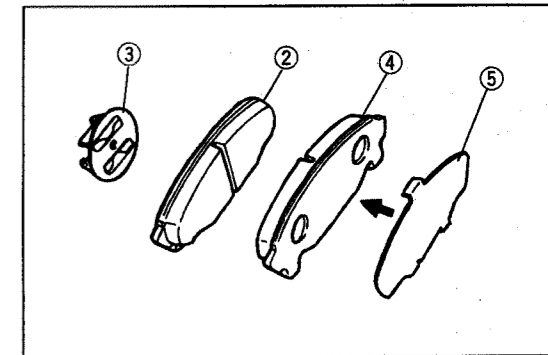

G2BR00082-00076

3. Install the disc brake pad guide plate No. 1 on the disc brake cylinder mounting.
4. Install the disc brake pad guide plate No. 2 on the disc brake cylinder mounting.

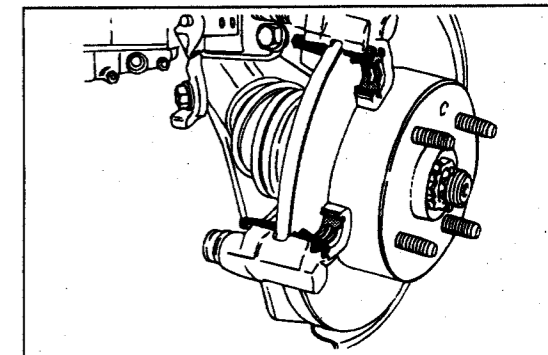

G2BR00083-00073

5. Install the brake pad in conjunction with anti-squall shim in the disc brake cylinder mounting.

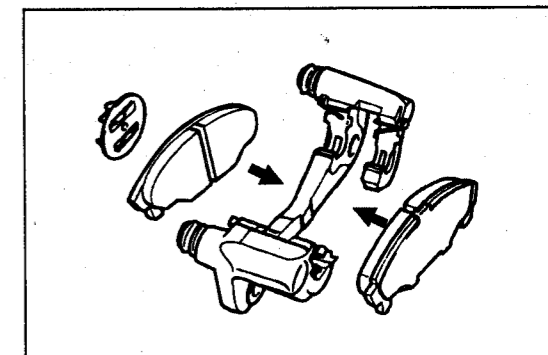

G2BR00084-00078

6. Install the disc brake cylinder assembly with cylinder slide pin No. 1. Tighten the pin.

Tightening Torque: 38 - 49 N-m (380 - 500 kgf-cm)

7. Install the brake hose bracket.

Tightening Torque: 7 - 15 N-m (70 - 160 kgf-cm)

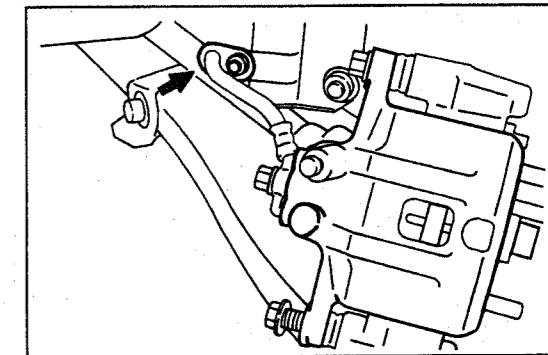

G2BR00085-00079

REPLACEMENT OF CALIPER RELATED PARTS

DISASSEMBLY

1. Drain the brake fluid from the master cylinder reservoir.
2. Disengage the brake hose from the disc brake cylinder assembly by removing the union bolt and gasket.
3. Remove the cylinder slide pin No. 1. Then, turn the cylinder assembly upward and slide out the disc brake cylinder assembly from the cylinder mounting.

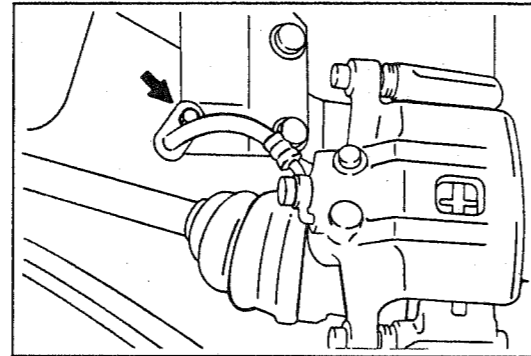

G2BR00086-00070

4. Remove the disc brake cylinder mounting by removing the attaching bolts.

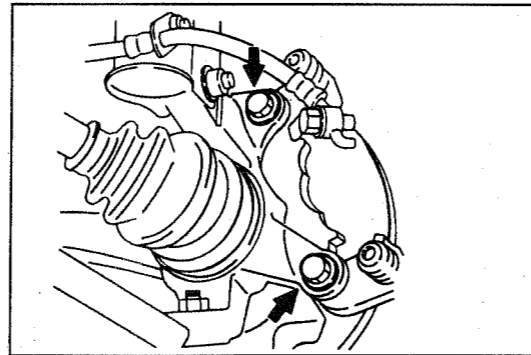

G2BR00087-00081

5. Remove the pin boot from the disc brake cylinder mounting.

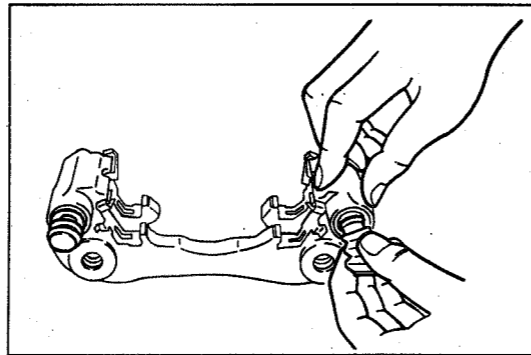

G2BR00088-00082

NOTE:

- Replace the front disc brake cover, as required. Refer to page FS-11.

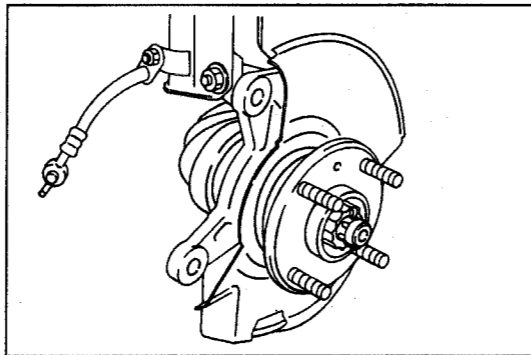

G2BR00089-00083

ASSEMBLY

1. Prepare the following new parts.

- Pin boots

NOTE:

- Also, replace any damaged part(s).

2. Apply rubber grease to the inside of the pin boot. Then, install the pin boot to the disc brake cylinder mounting by hand.

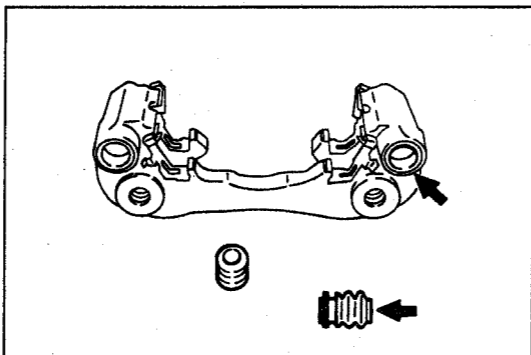

G2BR00090-00084

3. Install the disc brake cylinder mounting to the steering knuckle with the attaching bolts.

Tightening Torque: 90 - 135 N·m (920 - 1380 kgf·cm)

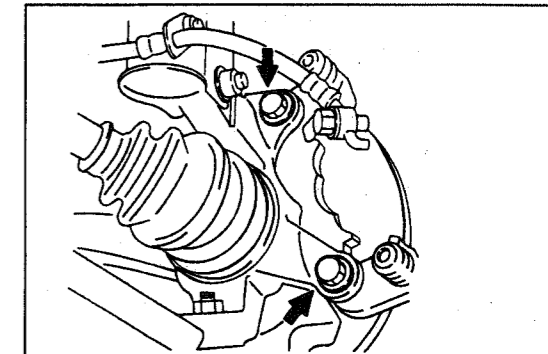

G2BR00091-00081

4. Install the disc brake pad.

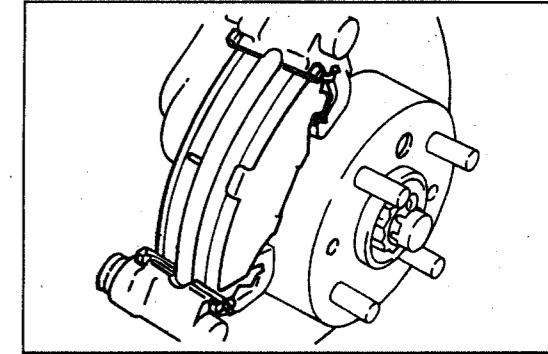

G2BR00092-00086

REPLACEMENT OF CUP AND DUST SEAL

DISASSEMBLY

1. Detach the cylinder boot set ring and cylinder boot, using a screwdriver.

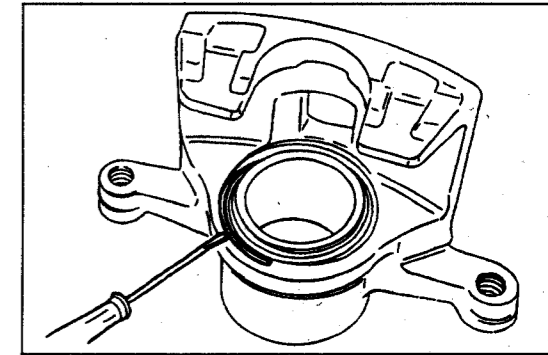

G2BR00093-00087

2. With a wooden piece or a cloth placed at the end of the disc cylinder, as indicated in the illustration. Drive out the piston by applying compressed air.

CAUTION:

- Special caution must be exercised so that no brake fluid may be splashed. Also, be very careful not to allow your finger be pinched.

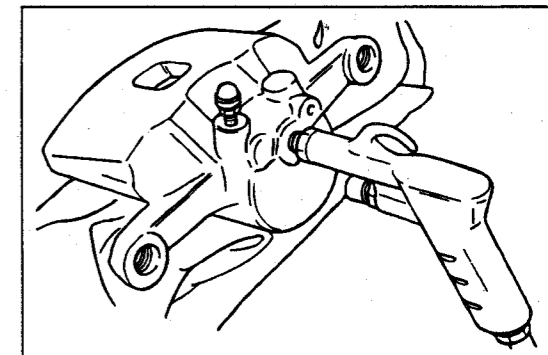

G2BR00094-00088

3. Detach the piston seal, using a screwdriver.

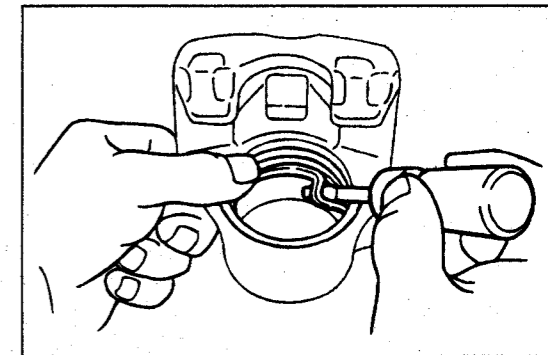

G2BR00095-00089

ASSEMBLY

1. Prepare the following new parts.

- Piston seal
- Cylinder boot
- Set ring
- Bush dust boot

NOTE:

- Also, replace any damaged parts.
- Apply brake rubber grease to those points indicated in the illustration.

2. Assemble the piston seal seal in the disc brake caliper.

3. Insert the piston into the caliper, making sure that the piston is not tilted during the installation.

4. Assemble the cylinder boot in the caliper.

NOTE:

- Make sure that the boot is fitted securely in the groove.

5. Assemble the cylinder boot set ring, making sure not to scratch the boot.

INSTALLATION

1. Place the disc brake cylinder to the disc brake cylinder mounting.

2. Install the cylinder slide pin No. 1 and No. 2 to the disc brake cylinder. Then, Tighten the bolts.

Tightening Torque: 38 - 49 N·m (380 - 500 kgf·cm)

NOTE:

- Care must be exercised so that the caliper boot may not be pinched during the installation.

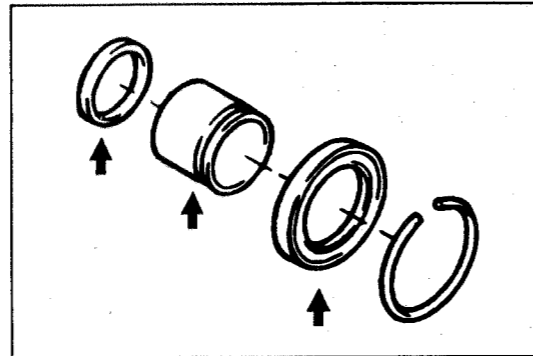

G2BR00096-00090

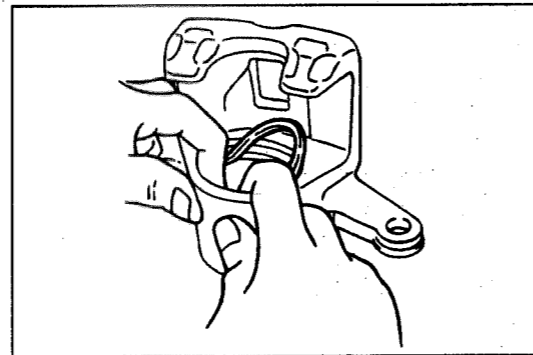

G2BR00097-00091

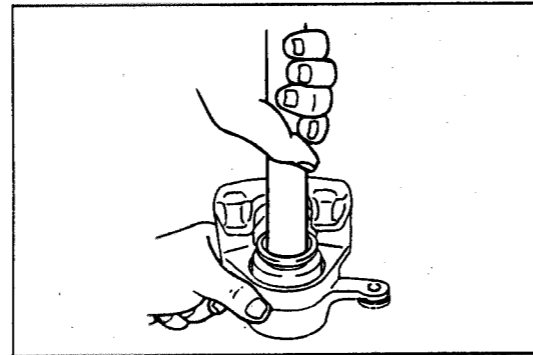

G2BR00098-00092

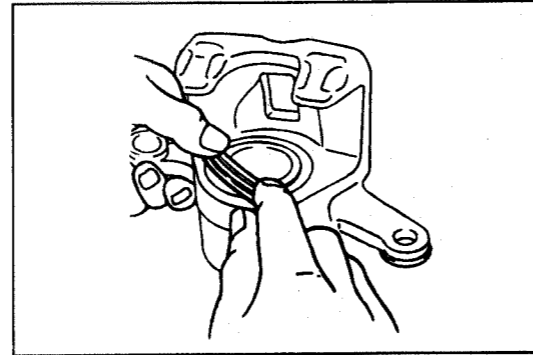

G2BR00099-00093

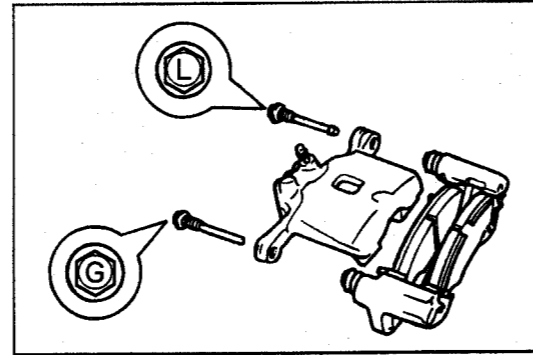

G2BR00100-00094

3. Install the brake hose with new gasket interposed.
Tightening Torque: 27 - 34 N·m (270 - 350 kgf·cm)

NOTE:

- Make sure that the brake hose is not twisted or stretched.
- After completion of the installation, turn the steering wheel from lock to lock position. Make sure that the brake hose is not interfering with any part of the body.

4. Install the brake hose bracket to the shock absorber.

5. Perform air bleeding for the brake system.
Refer to page BR-4.

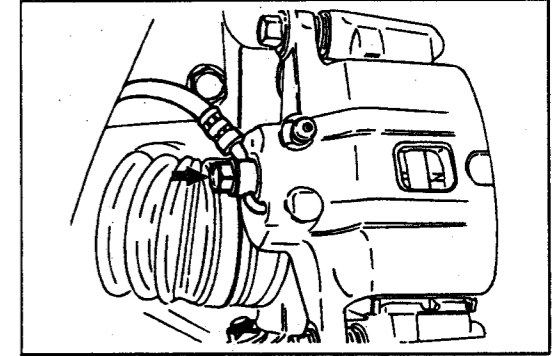

G2BR00101-00095

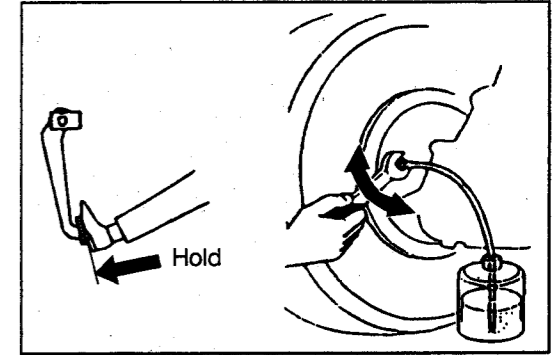

G2BR00102-00096

REAR DRUM BRAKES COMPONENTS

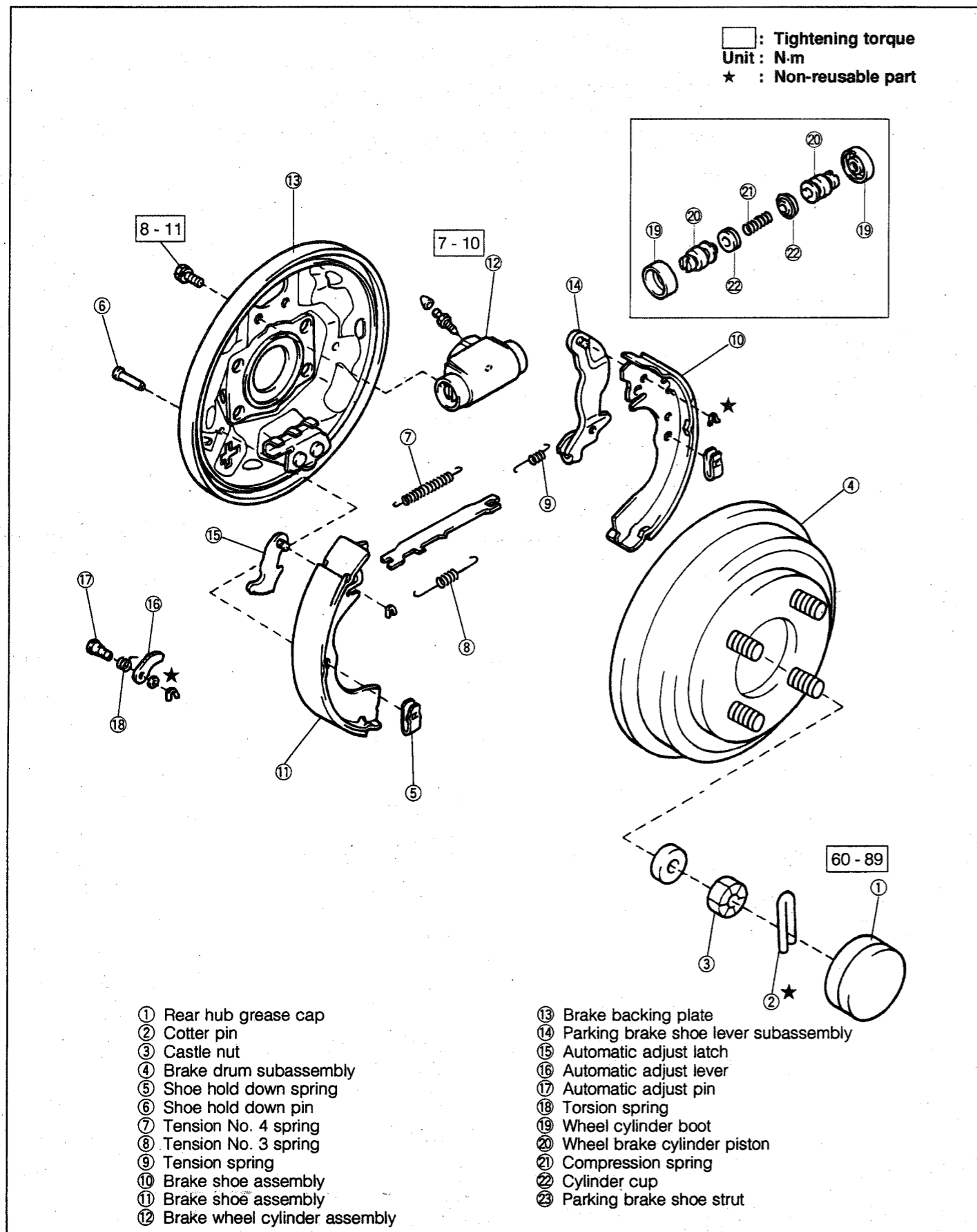

G2BR00103-00097

INSPECTION OF BRAKE SHOE & DRUM

- Remove the gum plug at the inspection hole provided on the backing plate.
- Inspect the brake shoe lining wear through the inspection hole.

Allowable Limit: 1 mm

- Jack up the vehicle with safety stands.
- Remove the rear wheels.
- Remove the grease cap, cotter pin, lock cap, castle nut and conical washer.
- Remove the brake drum, using the following SST.
SST: 09510-87301-000

- Inspect the brake drum diameter.
Specified Diameter: 180 mm
Allowable Limit: 181 mm

- Inspect the brake lining thickness.
Specified Thickness: 4.0 mm
Allowable Limit: 1 mm

- Inspection of working face of the brake shoe with the brake drum.

- Apply powder of chalk to the brake drum. Then, check the brake shoe attaching surface of the brake drum for warpage by means of hand lapping.
- Clean the brake shoe and brake drum after the hand lapping of the brake shoe.

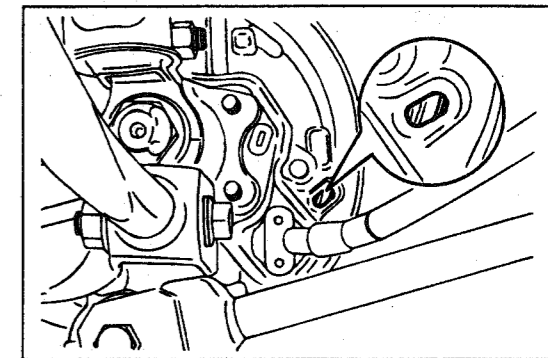

G2BR00104-00098

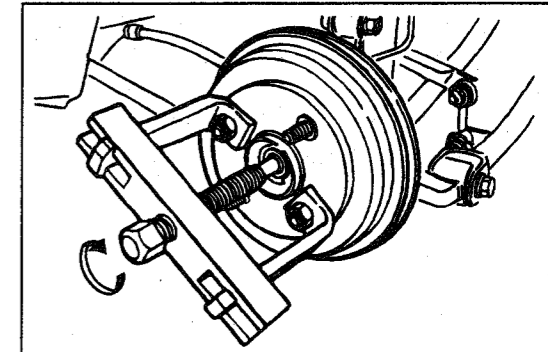

G2BR00105-00099

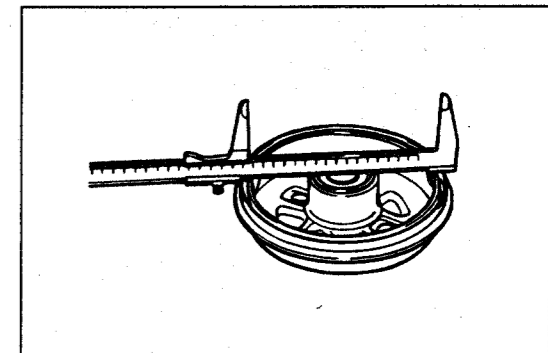

G2BR00106-00100

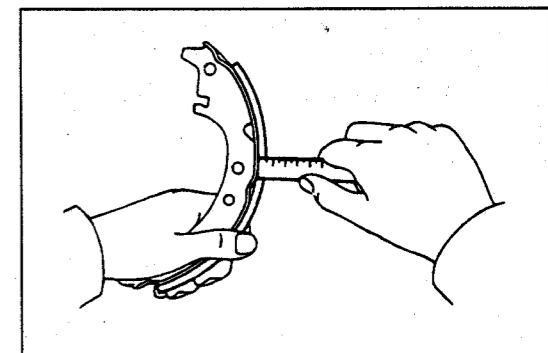

G2BR00107-00101

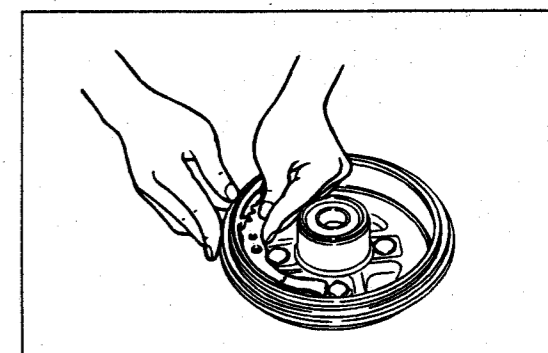

G2BR00108-00102

REPLACEMENT OF WHEEL CYLINDER

1. Remove the tension No. 4 spring.
2. Remove the brake tube from the wheel cylinder, using the brake pipe wrench.
3. Remove the attaching bolts of the wheel cylinder. Proceed to remove the wheel cylinder from the backing plate.

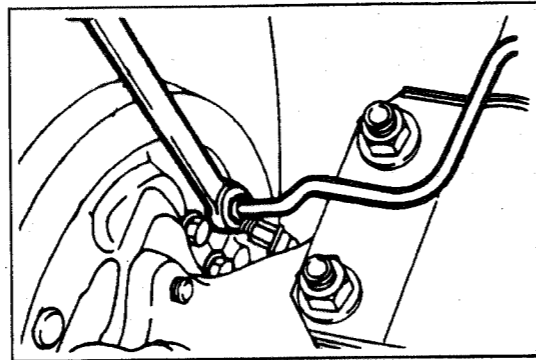

G2BR00109-00103

4. Disassembly of wheel cylinder
 - (1) Remove the wheel cylinder boot.
 - (2) Remove the wheel cylinder piston with cup
 - (3) Remove the compression spring.
5. Prepare the rear wheel cylinder repair kit.
 - Wheel cylinder boot ①
 - Wheel cylinder piston cups ②
 - Compression spring ③

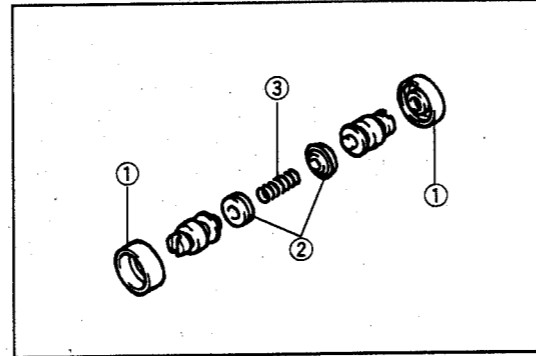

G2BR00110-00104

6. Assemble the cup on the wheel cylinder piston.

NOTE:

 - Be sure to install the cup in the correct direction.
 - Apply brake rubber grease to the piston cup.

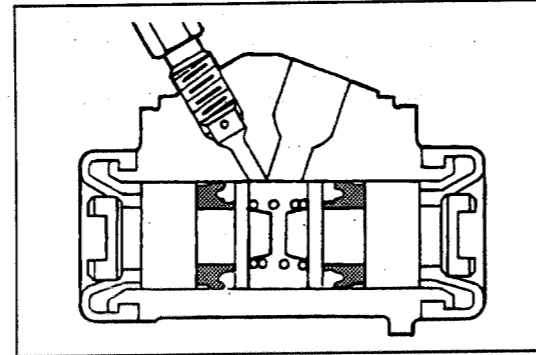

G2BR00111-00105

7. Assemble the pistons and compression spring to the wheel cylinder.
8. Assemble the wheel cylinder boots to the wheel cylinder.

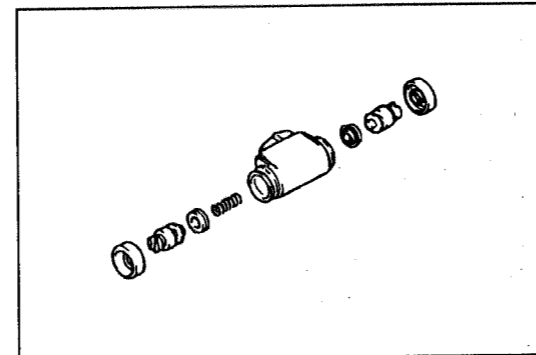

G2BR00112-00106

9. Install the rear wheel brake cylinder to the backing plate.

Tightening Torque: 8 - 11 N·m (80 - 120 kgf·cm)

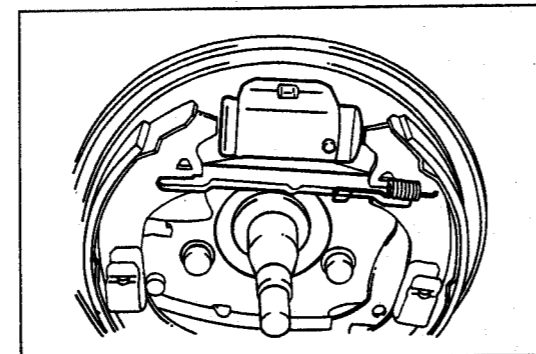

G2BR00113-00107

10. Install the brake tube to the wheel cylinder temporarily by hand. Then, tighten the nut of brake tube, using the brake tube wrench.

Tightening Torque: 13 - 17 N·m (130 - 180 kgf·cm)
11. Install the tension No. 4 spring to the brake shoe sub-assembly.

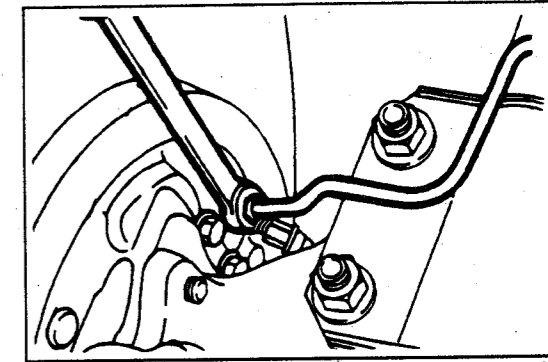

G2BR00114-00103

REPLACEMENT OF BRAKE SHOE & BACKING PLATE

1. Removal of shoe assembly
 - (1) Remove the tension No. 4 spring.
 - (2) Remove the tension spring.

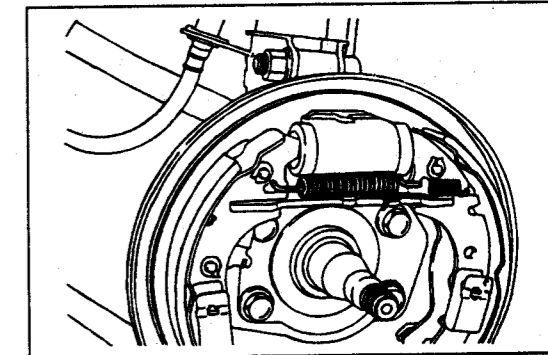

G2BR00115-00109

- (3) Remove the shoe hold-down pins from the shoe hold-down springs.
- (4) Remove the tension No. 3 spring from the shoe.

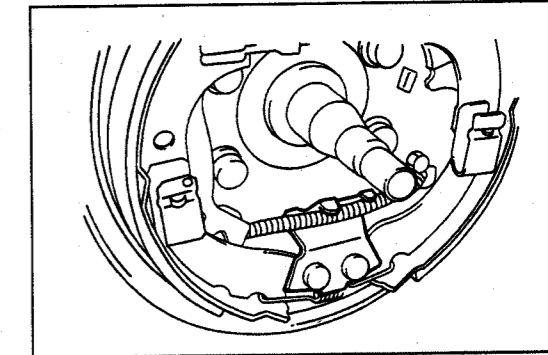

G2BR00116-00110

- (5) Remove the parking brake cable from the parking brake shoe lever.
- (6) Remove the parking brake cable from the backing plate.

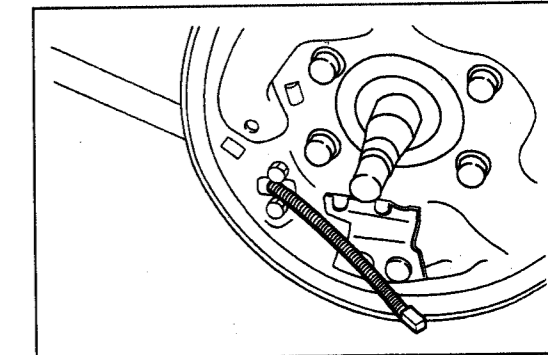

G2BR00117-00111

2. Disassembly of shoe
 - (1) Disengage the parking brake shoe lever ① from the shoe by removing the C-ring ②.

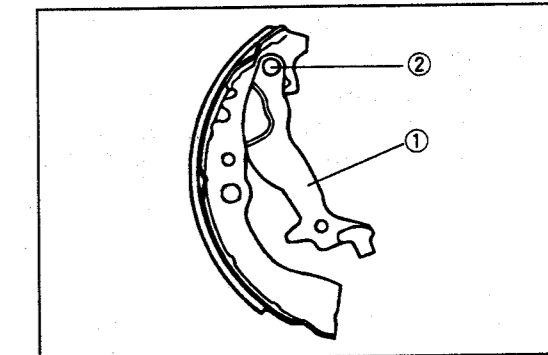

G2BR00118-00112

- (2) Remove the strut ③.
- (3) Disengage the automatic adjust latch ④ from the shoe by removing the C-ring.
- (4) Disengage the automatic adjust lever ⑤, automatic adjust pin ⑥ and torsion spring ⑦ from the shoe by removing the C-ring.

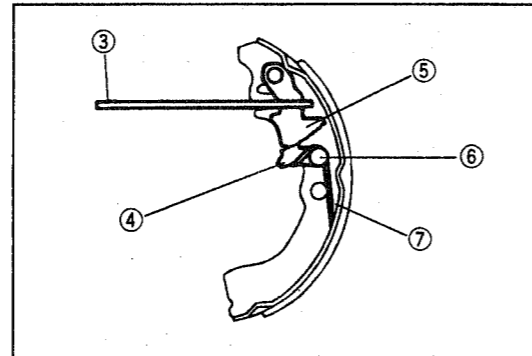

G2BR00119-00113

3. Inspect the backing plate for damage or wear.
4. Replacement of backing plate

NOTE:

- Do not remove the backing plate, unless its replacement is required due to the damage or deformation.

- (1) Remove the wheel cylinder.
- (2) Remove the parking brake cable by removing the attaching bolts.
- (3) Remove the rear brake backing plate from the rear axle carrier.
- (4) Install the backing plate to the axle carrier.
Tightening Torque: 44 - 58 N·m (450 - 600 kgf·cm)
- (5) Route the parking brake cable through the backing plate. Tighten the attaching bolts.
Tightening Torque: 7 - 9 N·m (64 - 96 kgf·cm)

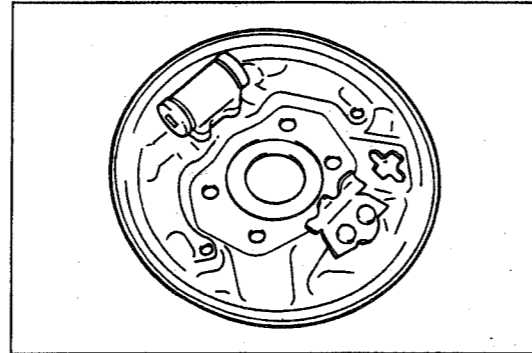

G2BR00120-00114

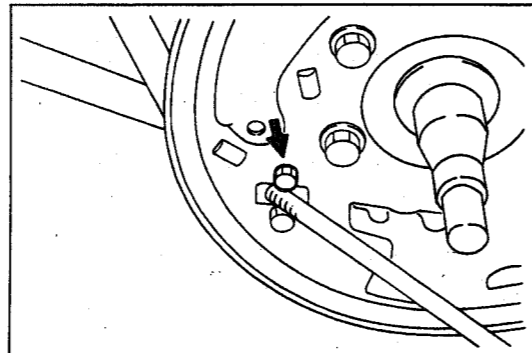

G2BR00121-00115

5. Prepare the following parts.

- (1) Rear brake shoe kit
(For rear right wheel and rear left wheel)

NOTE:

- The brake shoe must be replaced at both right and left sides of the wheel at the same time.

- (2) New C-ring
(For six pieces)

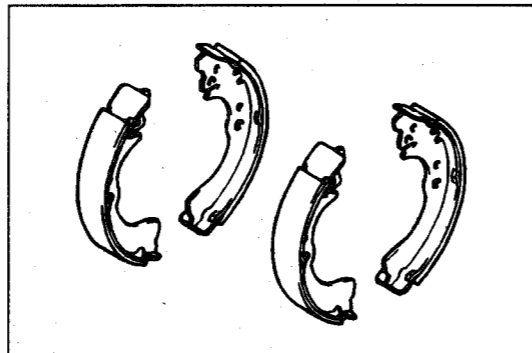

G2BR00122-00116

6. Assembly of brake shoe

- (1) Install the parking brake shoe lever to the brake shoe with a new C-ring.
- (2) Install the automatic adjusting lever and related parts to the brake shoe with a new C-ring.

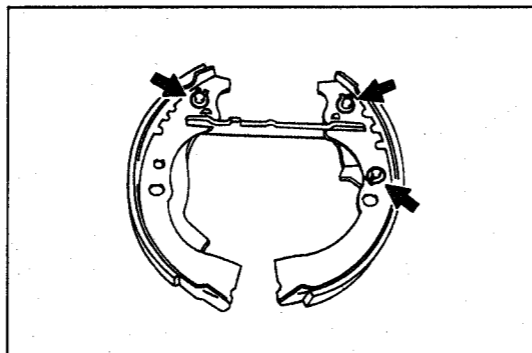

G2BR00123-00117

7. Installation of brake shoe

- (1) Apply brake grease to the 6 points at ledge surface of the backing plate with the brake shoe.

NOTE:

- Be careful not to allow lubricants, such as grease, to get the wheel cylinder boot or shoe lining.

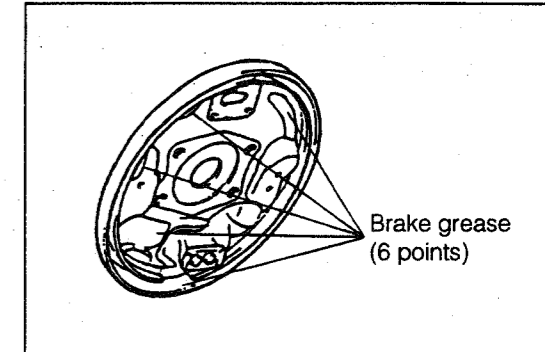

G2BR00124-00118

- (2) Connect the parking brake cable to the parking brake shoe lever, using a pliers.

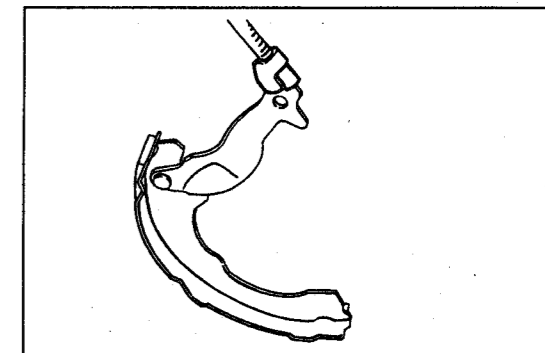

G2BR00125-00119

- (3) Install the tension No. 3 spring to the brake shoes.
- (4) Assemble the brake shoes on the backing plate. Then, install the shoe-down spring and pin.
- (5) Install the tension spring.
- (6) Install the tension spring No. 4.

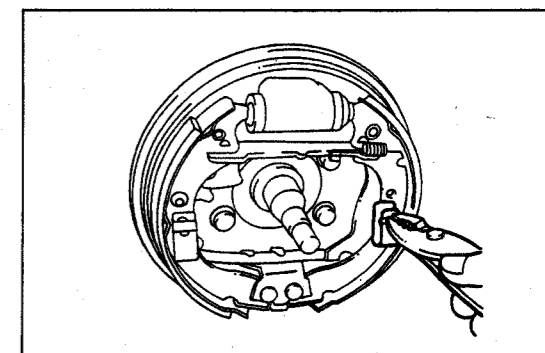

G2BR00126-00120

8. Install the brake drum provided with the wheel bearing and secure it with the plate washer and the bearing lock nut.
Tightening Torque: 60 - 89 N·m (610 - 910 kgf·m)

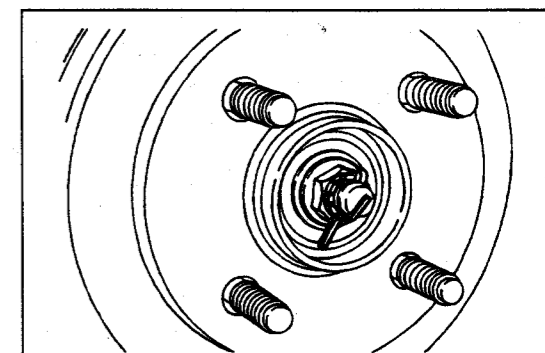

G2BR00127-00121

9. Install the new cotter pin and the grease cap.
Refer to page RS-8.

10. Perform air bleeding for the brake system.
Refer to page BR-4.

11. Depress the brake pedal. Ensure that the automatic adjusting mechanism emits operating sounds. Continue this operation, until you no longer hear any operating sound.

12. Adjust the working travel of the parking brake lever.
Refer to page BR-34.

13. Install the rear wheels.

14. Lower the vehicle with jack.

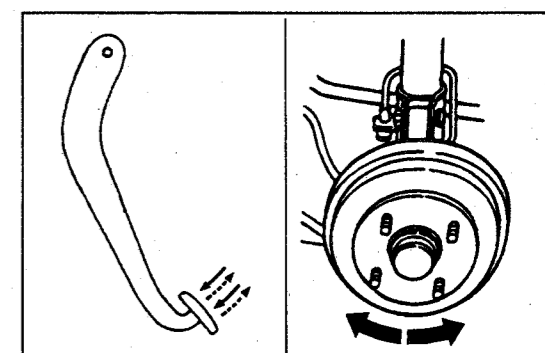

G2BR00128-00122

PARKING BRAKE COMPONENTS

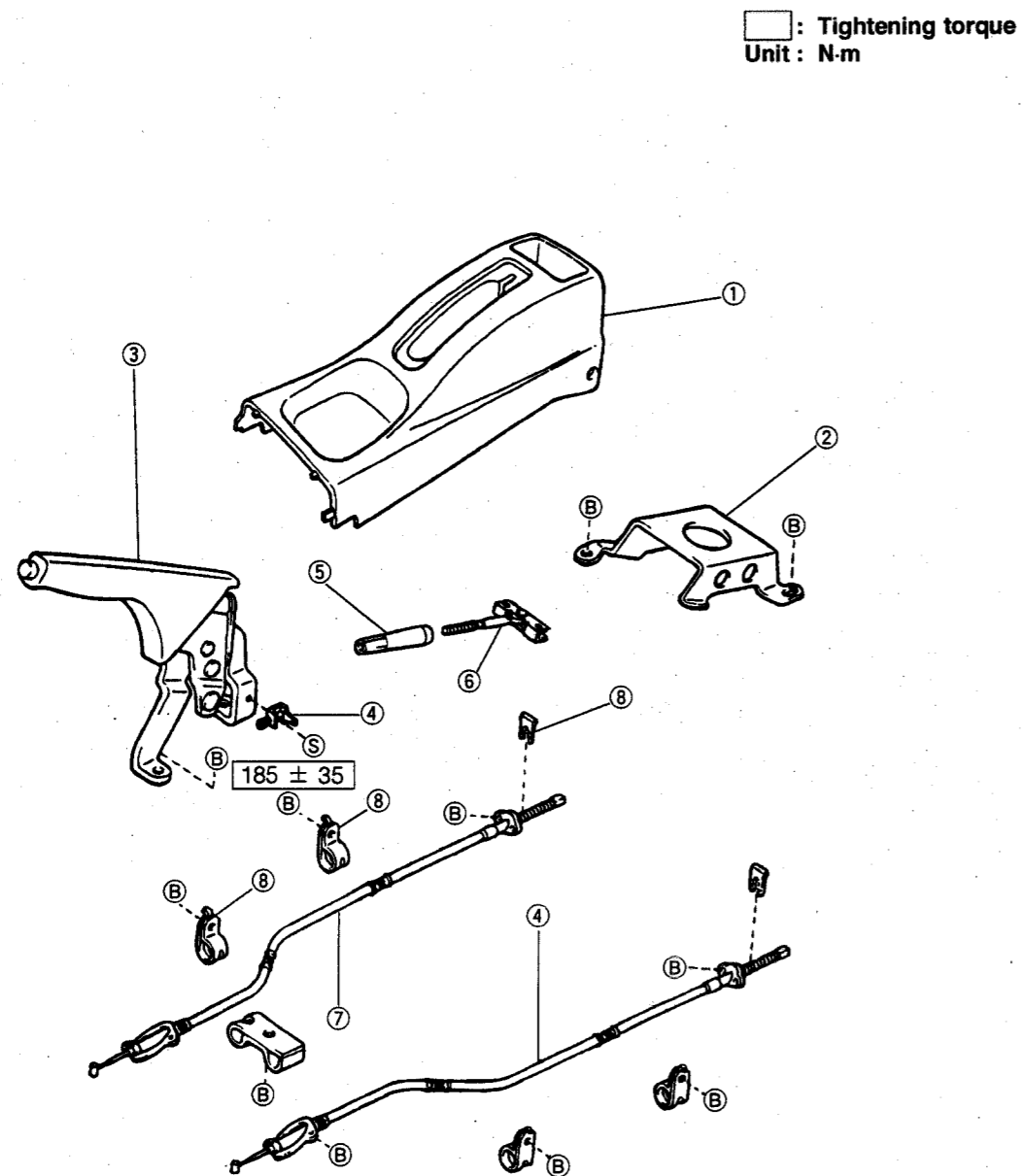

- ① Rear console box
- ② Parking brake tube protector
- ③ Parking brake handle assembly
- ④ Switch
- ⑤ Adjusting nut
- ⑥ Parking brake pull rod
- ⑦ Parking brake cable assembly
- ⑧ Clamp

G2BR00160-00154

REMOVAL

1. Remove the screws provided at the side of the rear console box. Take out the rear console box, as required.
2. Remove the carpet located beneath the parking brake lever. Remove the parking brake tube protector, as required.
3. Remove the adjusting nut from the parking brake pull rod. Disconnect the connector of the parking brake switch. Disconnect the parking brake cable from the parking brake pull rod.
4. Remove the parking brake lever assembly from the body.
5. Remove the parking brake switch from the parking brake lever assembly.
6. Jack up the vehicle. Remove the clamp-related parts provided under the body.
7. Removal of rear brake-related parts.
(Drum brake)
 - (1) Remove the rear wheels. Then, remove the brake drum. Refer to page RS-5.
 - (2) Remove the brake shoe.
 - (3) Disconnect the parking brake cable from the brake shoe.
 - (4) Remove the parking brake cable assembly from the backing plate.

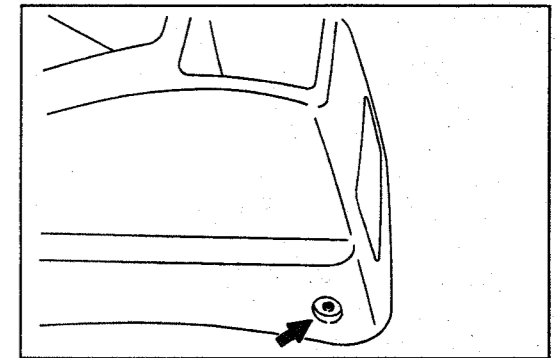

G2BR00161-00155

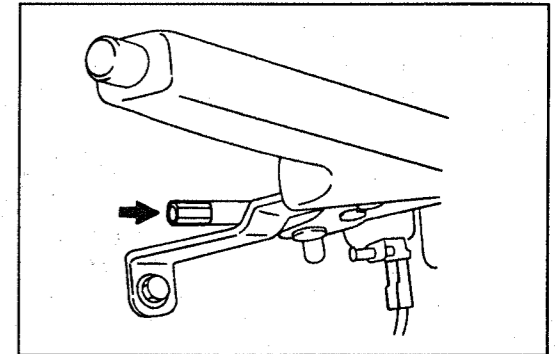

G2BR00162-00156

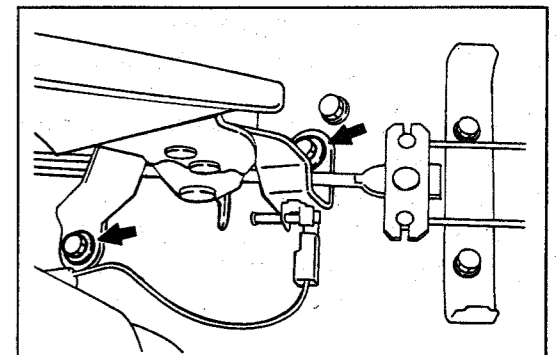

G2BR00163-00157

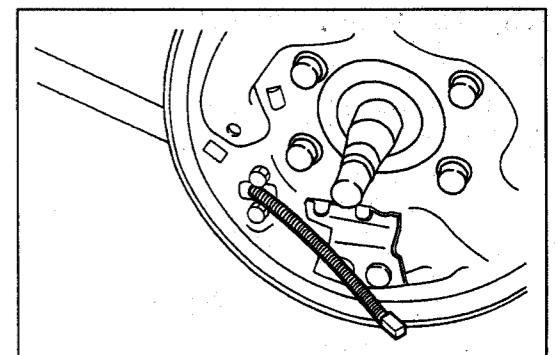

G2BR00164-00111

INSTALLATION

- Installation of rear brake-related parts (Drum brake)
 - Install the parking brake cable to the rear brake backing plate.
Tightening Torque: 7 - 9 N·m (64 - 96 kgf·cm)
 - Connect the parking brake cable to the parking brake shoe lever.
 - Install the brake shoe-related parts.
 - Install the brake drum.
- Install the clamp-related parts provided under the body.
Tightening Torque: 4 - 7 N·m (40 - 70 kgf·cm)
- Install the parking brake switch to the parking brake handle assembly.
- Install the parking brake handle assembly to the body.
Tightening Torque: 15 - 21 N·m (150 - 220 kgf·cm)
- Connect the connector of the parking brake switch.
- Connect the parking brake cable to the parking brake pull rod.
- Route the parking brake pull rod through the parking brake handle assembly.
- Install the adjusting nut.
- Ensure that the brake warning lamp goes on when the parking brake handle is pulled.

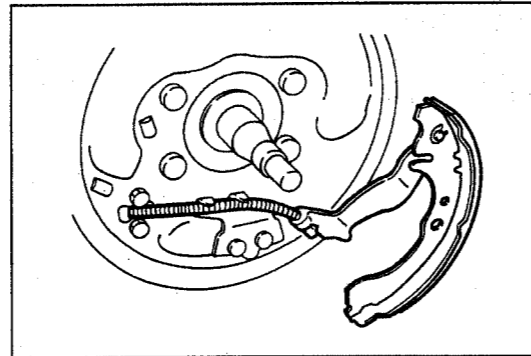

G2BR00166-00160

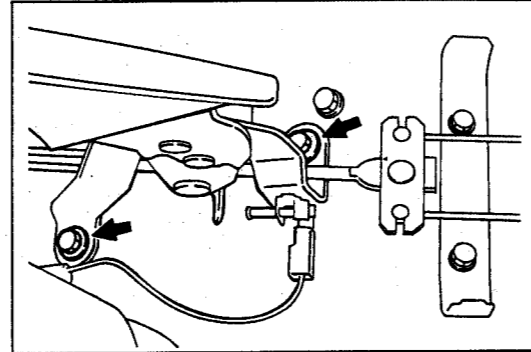

G2BR00168-00157

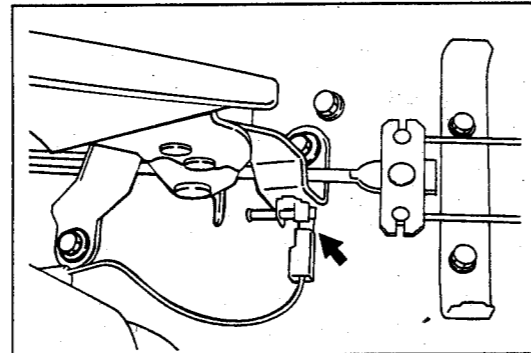

G2BR00169-00207

ADJUSTMENT OF WORKING TRAVEL

- Depressed the brake pedal repeatedly and fully, until no clicking sound occurs.
- Adjust the working travel to the specified value by means of the adjusting nut.
Specified Value: 4 - 7 notches
[When pulled by a force of 196 N (20 kgf, 44 lb.)]
- Reinstall the parts which were removed at the steps 1 and 2 of the removal.

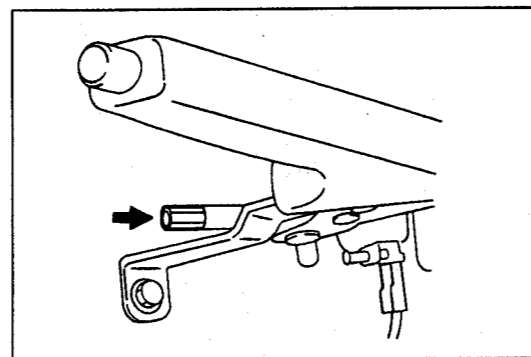

G2BR00170-00164

PROPORTIONING VALVE COMPONENTS

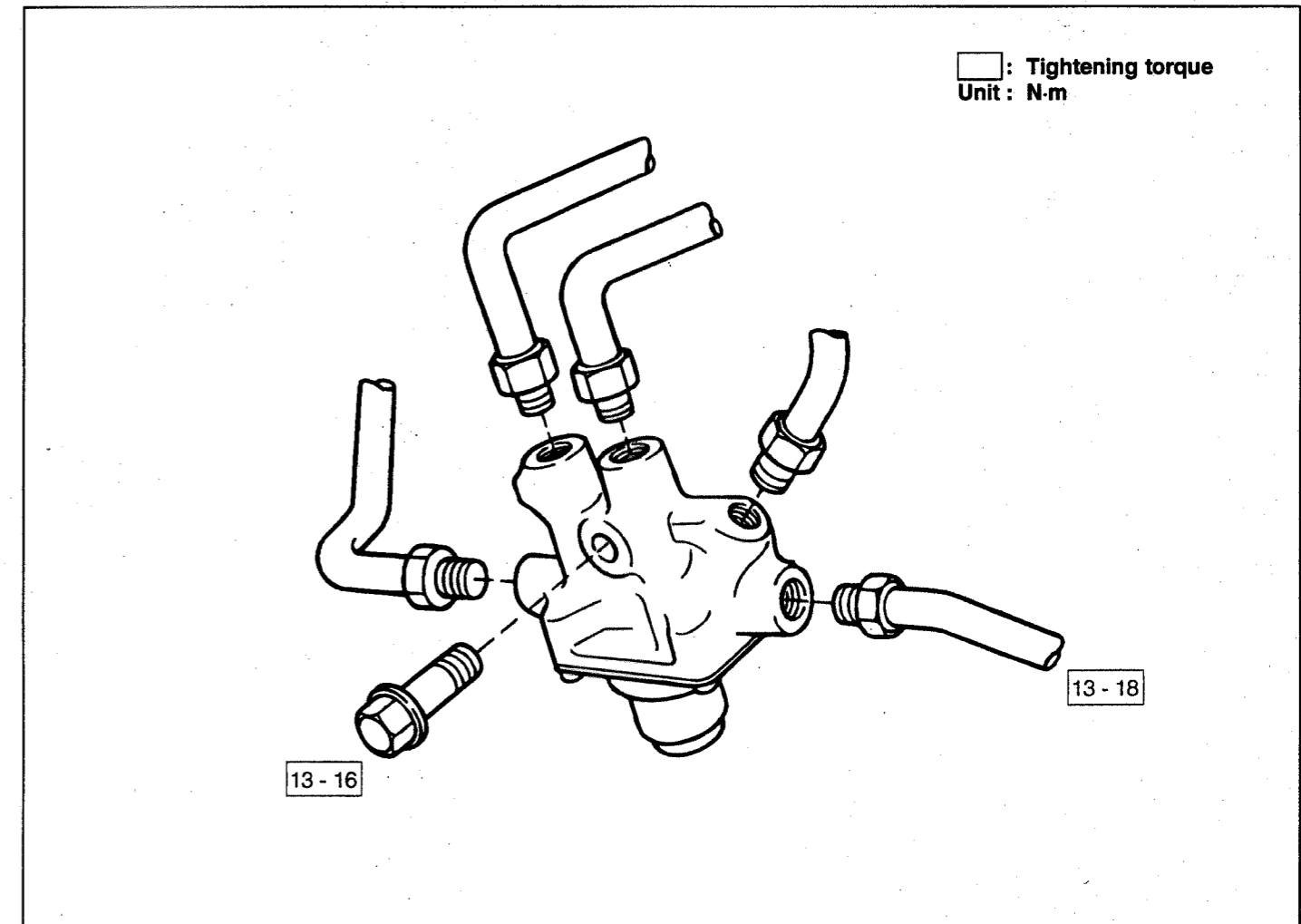

G2BR00171-00165

REPLACEMENT

- Open the engine hood.
- Remove the brake fluid from the master cylinder reservoir tank.
- Disconnect the brake tubes from the proportioning valve.
- Remove the bolt from the body.

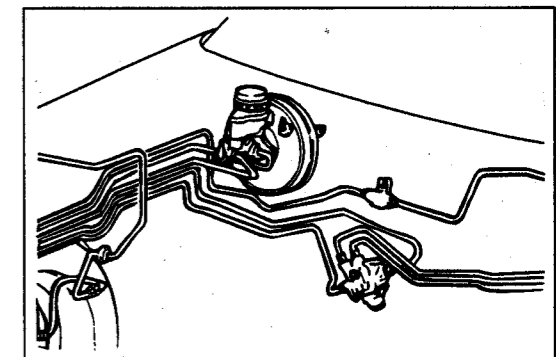

G2BR00172-00166

INSTALLATION

- Install new proportioning valve with the bolt.
Tightening Torque: 13 - 15 N·m (130 - 160 kgf·cm)
- Install the brake tubes to the proportioning valve.
Tightening Torque: 13 - 17 N·m (130 - 180 kgf·cm)
- Perform the air bleeding for the brake system.
Refer to page BR-4.

G2BR00173-00000

APPENDIX
SST

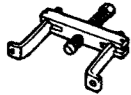
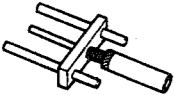
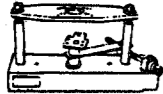
Shape	Part No.	Part name
	09510-87301-000	Front hub & drum puller
	09737-87002-000	Brake booster push rod gauge
	09753-87701-000	Brake booster overhaul tool S/A

G2BR00174-00167

SERVICE SPECIFICATIONS
BRAKE PEDAL

Unit: mm (inch)

Item		Specified value	Allowable limit	Remarks
Brake pedal	Free play	0.5 - 2 (0.02 - 0.08)	—	When engine is stopped
	Height	R.H.D. 151 - 156 (5.94 - 6.14)	—	
	Reserve travel	R.H.D. Not less than 72 (2.83)	—	Distance between center of pedal pad upper surface and dash panel

G2BR00175-00000

FRONT BRAKE

Unit: mm (inch)

Item	Specified value	Allowable limit	Remarks
Pad thickness	10.0 (0.39)	1.0 (0.04)	
Disc thickness	11.0 (0.43)	10.0 (0.39)	
Disc rotor run-out	—	0.10 (0.004)	On the 214 mm diameter

G2BR00176-00000

REAR BRAKE

Unit: mm (inch)

Item		Specified value	Allowable limit	Remarks
Drum brake	Inner diameter	180 (7.09)	181 (7.13)	
	Lining thickness	4.0 (0.16)	1.0 (0.04)	
Parking brake lever working travel	Drum brake	4 - 7 notches	—	Pulling force: 196 N (20 kgf, 44 lb.)

G2BR00177-00000

BR-38

TIGHTENING TORQUE

Tightening components	Tightening torque		
	N-m	kgf-cm	ft-lb
Bleeder plug	6.9 - 9.8	70 - 100	5.1 - 7.2
Booster clevis lock nut	11.8 - 17.6	120 - 180	8.7 - 13.0
Booster valve with rod, lock nut	17.7 - 24.5	180 - 250	13.0 - 18.1
Brake booster × Body	9.8 - 15.7	100 - 160	7.2 - 11.6
Brake booster × Master cylinder	11.8 - 17.7	120 - 180	8.7 - 13.0
Brake hose × Disc brake cylinder	26.5 - 34.3	270 - 350	19.5 - 25.3
Brake tube × Master cylinder	12.7 - 17.7	130 - 180	9.4 - 13.0
Brake tube × Wheel cylinder	12.7 - 17.7	130 - 180	9.4 - 13.0
Disc brake, front brake rotor × Axle hub	1.0 - 2.9	10 - 30	0.7 - 2.2
Disc brake, front cylinder mounting × Knuckle	90.2 - 135.0	920 - 1380	66.5 - 99.8
Disc brake, dust cover × Axle carrier	44.1 - 58.8	450 - 600	32.5 - 43.4
Master cylinder piston set bolt	6.9 - 10.8	70 - 110	5.1 - 8.0
Master cylinder × Reservoir assembly set bolt	1.0 - 2.0	10 - 20	0.7 - 1.4
Parking brake lever assembly × Body	14.7 - 21.6	150 - 220	10.8 - 15.9
Parking brake cable clamps × Body	3.9 - 6.9	40 - 70	2.9 - 5.1
Parking brake cable bracket × Backing plate	6.3 - 9.2	64 - 96	4.6 - 6.9
Wheel cylinder × Backing plate (Rear brake)	7.8 - 11.8	80 - 120	5.8 - 8.7

G2BR00178-00000