

DAIHATSU

G202

FRONT AXLE & SUSPENSION

COMPONENTS	FS- 2
WHEEL ALIGNMENT	FS- 3
PREPARATION	FS- 3
CAMBER	FS- 5
CASTER AND KINGPIN ANGLES	FS- 6
TOE-IN	FS- 7
TURNING RADIUS	FS- 8
FRONT AXLE	FS- 9
INSPECTION	FS- 9
REMOVAL	FS-10
INSTALLATION	FS-12
SHOCK ABSORBER AND SPRING	FS-15
INSPECTION	FS-15
INSTALLATION	FS-18
FRONT STABILIZER BAR	FS-19
INSPECTION	FS-19
INSTALLATION	FS-20
SUSPENSION LOWER ARM	FS-21
INSPECTION	FS-21
INSTALLATION	FS-23
DRIVE SHAFT & RELATED PARTS	FS-24
INSPECTION	FS-24
INSTALLATION	FS-30
SSTs	FS-32
TIGHTENING TORQUE	FS-34
SERVICE SPECIFICATIONS	FS-34

G2FS00001-00000

NO. 9188

COMPONENTS

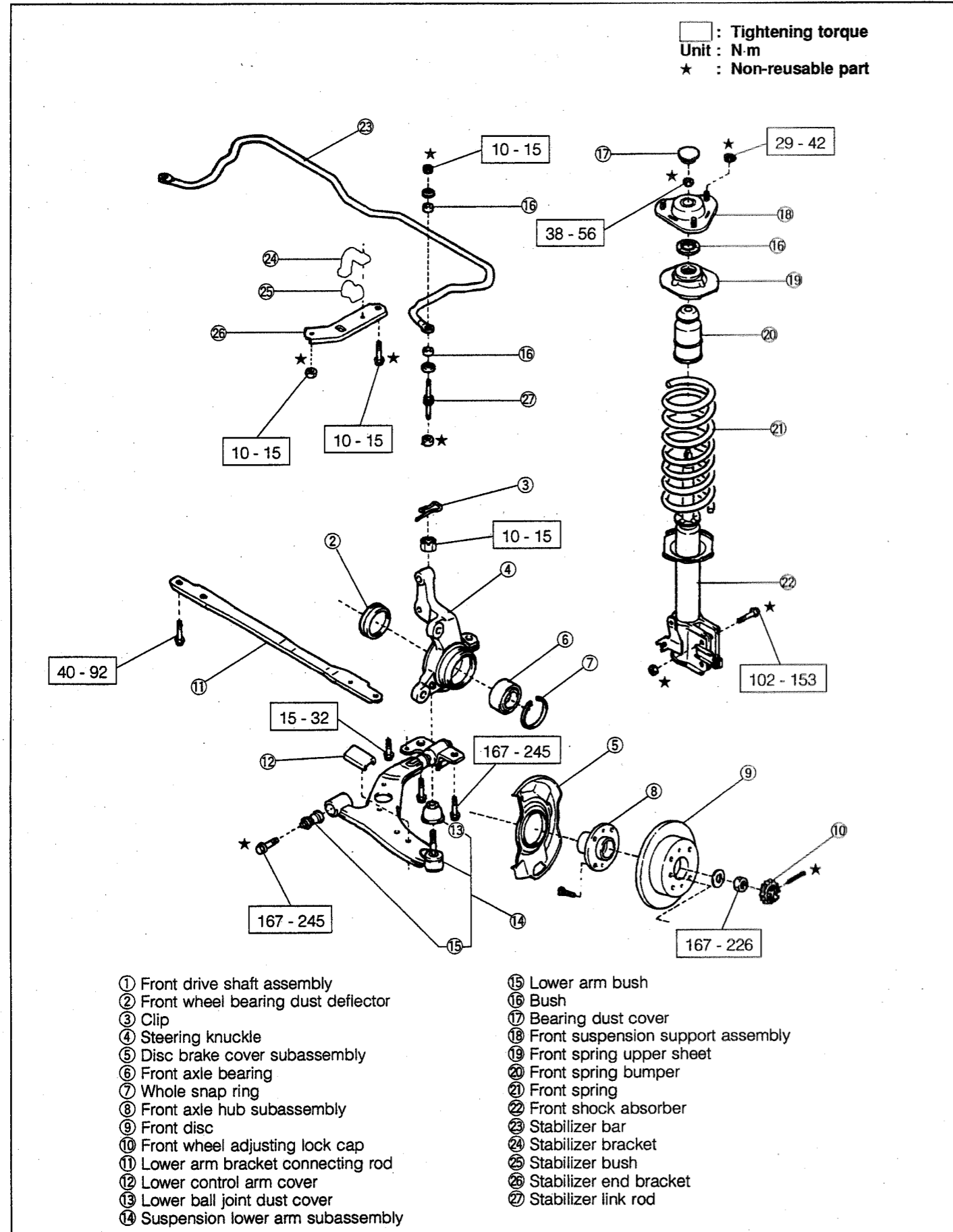

WHEEL ALIGNMENT

PREPARATION

Prior checks

1. Inspect the wear of the tires.
2. Inspect the air pressure of the tires.

NOTE:

- Perform the check on a level floor.
- Make sure that the wheels are same maker's tire and size.
- Keep the vehicle in an unloaded state. An unloaded state are fulfilled fuel tank, installed the spare tire, installed the standard tools and jack at correct storage locations.

Tire size	Air pressure	
	Front	Rear
145/80R13 74S	180 (1.8, 26)	180 (1.8, 26)
155/80R13 78S 6.15-13-4PR	200 (2.0, 29)*	200 (2.0, 29)*
	180 (1.8, 26)	180 (1.8, 26)

* For Australian

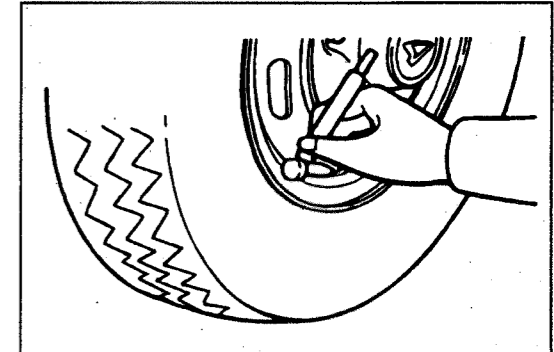

G2FS0003-0002

3. Inspect the runout of the tires.
Maximum Limit: 2 mm for Right-and-Left
1.4 mm for Up-and-Down

NOTE:

- The measurement should be conducted within five minutes after the vehicle has been run at least 30 minutes at a speed of 60 to 80 km/h.

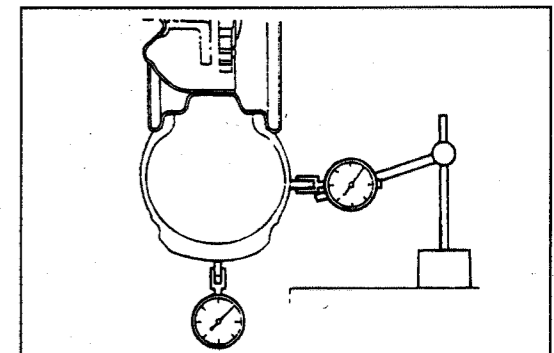

G2FS0004-0003

4. Check of bolts of related sections for tightened condition
5. Check of related sections for excessive amount of play
 - (1) Jack up the vehicle. Alternately push and pull the upper and lower parts of each tire. Ensure that the tire exhibits no excessive play.
 - (2) If the tire exhibits an excessive amount of play, perform the following check while the brake pedal is being depressed.

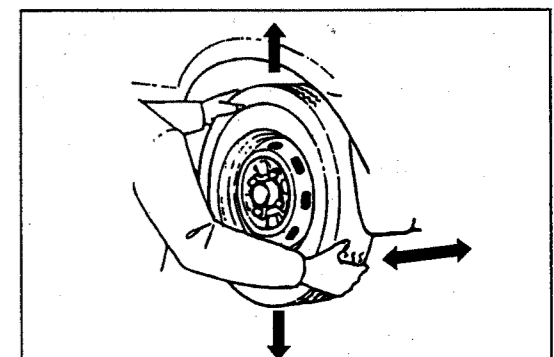

G2FS0005-0004

Installation procedure of the CCK gauge

- (1) Jack up the vehicle.
- (2) Compensate the mechanical zero line by turning the compensating dial of the compensator.

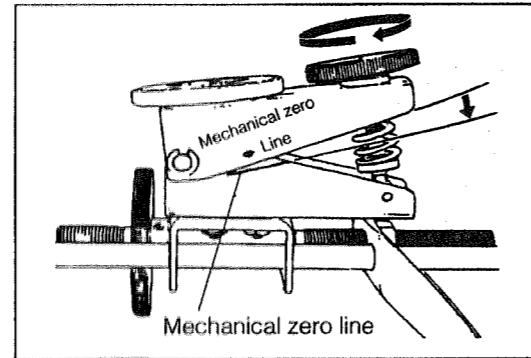

G2FS00006-00005

- (3) While turning the clamp dial of the CCK gauge compensator, hook the four pawls to the wheel edges securely. While pushing the compensator, lock the compensator positively by turning the clamp dial.

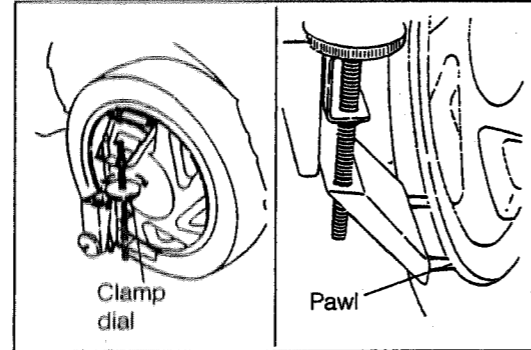

G2FS00007-00006

- (4) Set the camber, caster and kingpin gauge to the installation plate of the CCK gauge compensator. At this point, align the lines on the gauge and compensator with each other.

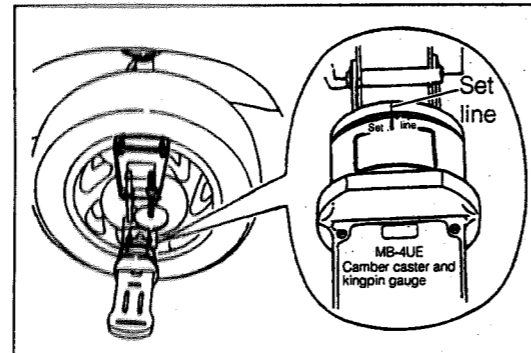

G2FS00008-00007

- (5) Turn the wheel so that the level air bubble in the gauge comes to the central position. At this position, turn the caster adjusting screw of the gauge so that the caster air bubble may be aligned with the graduation zero position.

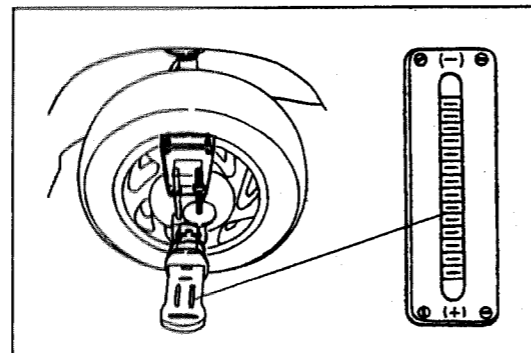

G2FS00009-00008

- (6) Turn the wheel 180 degrees so that the gauge may be turned over. Proceed to align the set lines on the gauge and compensator with each other. Next, turn the wheel so that the level air bubble in the gauge comes to the central position.
- (7) Record the caster reading of the gauge. Turn the compensating dial of the compensator so that it may be aligned with 1/2 of the recorded caster reading.

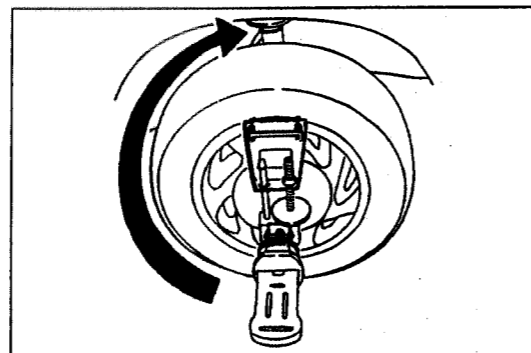

G2FS00010-00009

NOTE:

- Be sure not to tamper the caster adjusting screw of the gauge.

- (8) Repeat the steps described in (6) and (7). Ensure that the air bubble of the caster gauge registers the same reading when the wheel is turned 180 degrees in a normal direction and in a reversed direction.

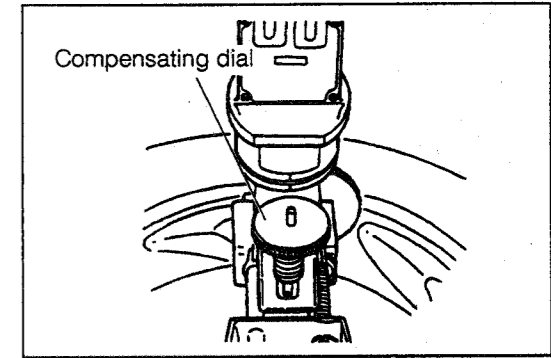

G2FS00011-00010

CAMBER

1. The wheel on the turning radius gauge. (Jack down the vehicle)
2. Rock the vehicle in an up-and-down direction so as to settle the suspension.
3. Ensure that the wheels are in their straight-ahead conditions.
4. Align the level air bubble with the central position.
5. Take the camber reading of the gauge.

Specified Value: $0^{\circ}20' \begin{matrix} +40' \\ -20' \end{matrix}$

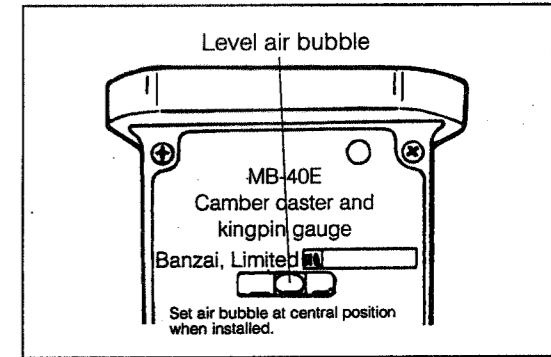

G2FS00012-00011

CASTER AND KINGPIN ANGLES

Right wheel

1. Turn the steering wheel to the right side, until the right front tire comes at a point where the turning radius gauge registers 20 degrees.
2. Turn each of the caster and king-pin adjusting screws so that the respective air bubble may be aligned with the zero point.
3. Turn the steering wheel to the left side, until the right front tire comes at a point where the turning radius gauge registers 20 degrees.
4. Take the gauge readings of the caster and king-pin angle.

Specified Value: Caster $1^{\circ}55' \begin{smallmatrix} +1^{\circ} \\ -20' \end{smallmatrix}$
 King-pin angle $12^{\circ} \pm 30'$

Left wheel

Perform the check, following the same procedure as with the right wheel. However, the turning direction of the steering wheel must be reversed.

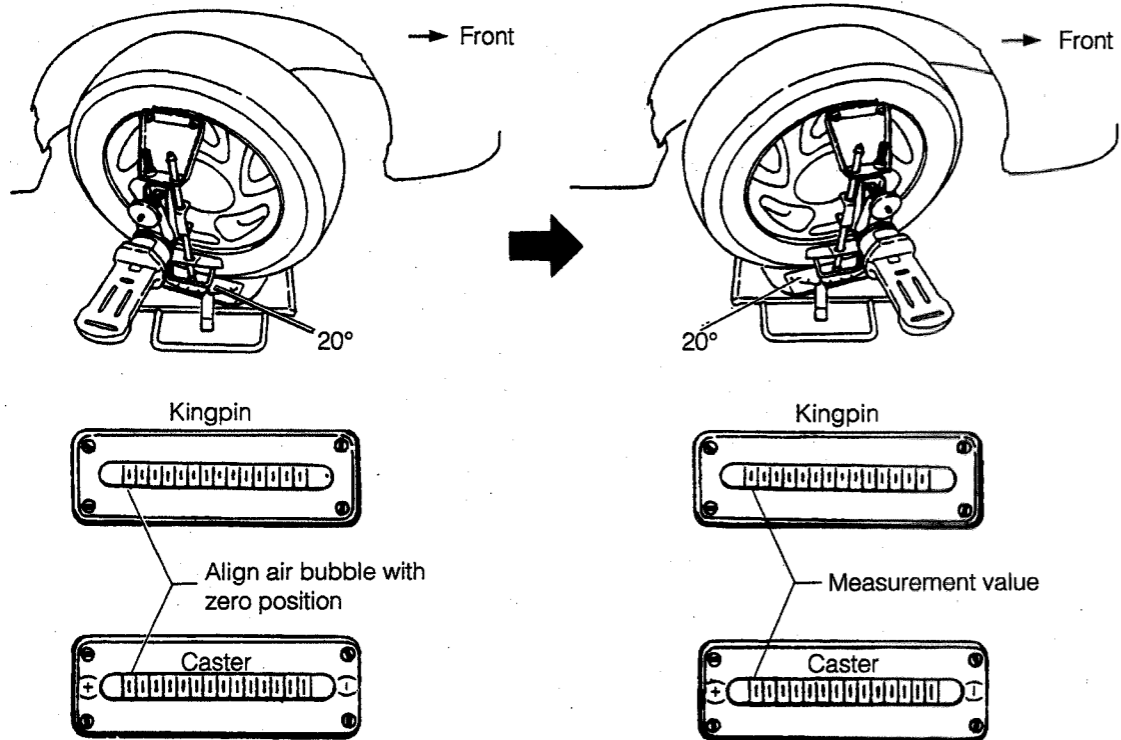

G2FS00013-00012

TOE-IN

Inspection

1. Rock the vehicle so that the vehicle height may stabilize.
2. Move the vehicle forward about five meters so that the front wheels may become in their straight-ahead conditions.

NOTE:

- Do not move the vehicle backward during the measurement.

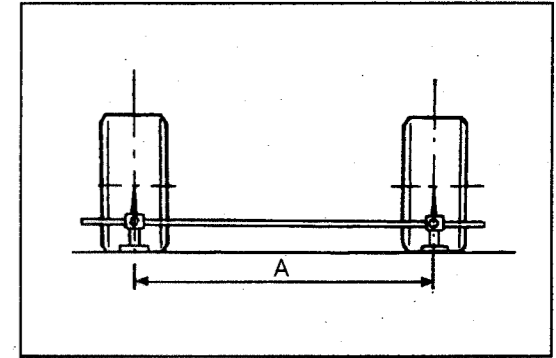

G2FS00014-00013

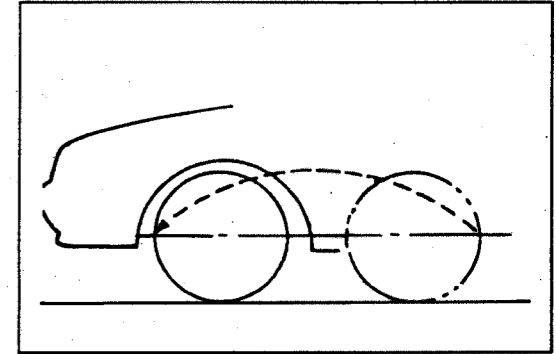

G2FS00015-00014

3. Align the height of the toe-in gauge pointers with the center height of the front wheels.
4. Put a mark on the tread center of each front wheel tire at the rear side. Measure the distance between the two marks (Dimension A) in the illustration.
5. Slowly move the vehicle forward by pushing the vehicle, until the wheels turn 180 degrees.

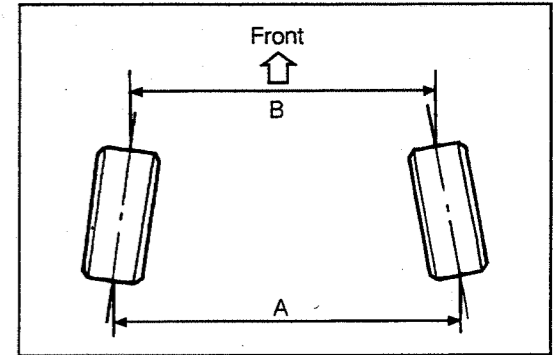

G2FS00016-00015

6. Measure the distance (Dimension B) between the two marks which were put in the preceding step. This measurement is performed at the front side of the vehicle. Calculate the amount of toe-in, i.e. (Dimension A - Dimension B)

Specified Value: $1 \pm 1 \text{ mm}$

Adjustment

1. Loosen the lock nuts of the tie-rod ends.
2. Perform the toe-in adjustment by turning the tie-rod ends.

NOTE:

- When adjusting the toe-in, the tie-rods at the right and left side should be turned by the same amount.
- Make the length (a) indicated in the illustration, equal between the right and left sides. If the length differs between the right and left sides, a difference occurs in the wheel turning angle between the right and left sides.

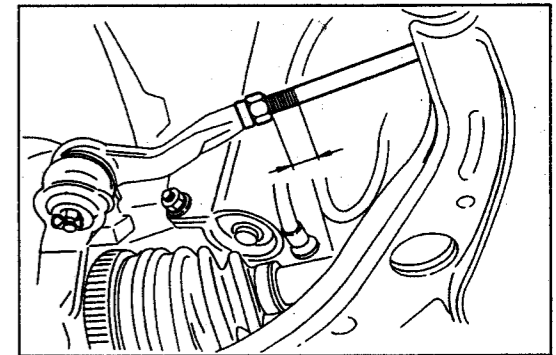

G2FS00017-99999

TURNING RADIUS

Gauge setting

- (1) Set the turning radius gauge to the zero point. Proceed to lock the gauge.
- (2) Place the vehicle on the gauge in such a way that the center tire-to-floor contact surface may be aligned with the center of the turning radius gauge.

NOTE:

- When a portable type turning radius gauge is employed, a plate having the same thickness of the gauge should be placed under the rear wheel so that the vehicle levelness may be maintained.
- Make sure that the wheels are in their straight ahead conditions.
- Remove the stop lamp fuse so as to prevent the stop lamp from staying on.
- Bounce the vehicle up and down to stabilize the suspension.

1. Check of wheel turning angle

- (1) Measure the wheel turning angle, using a turning radius gauge.
Specified Value: 39°45' ± 2° for Inner side (B)
34°30' ± 2° for Outer side (A)

- (2) If the wheel turning angle differs between the right and left sides, correct the turning angle.

2. Correction of wheel turning angle

- (1) Loosen the lock nuts of the tie-rod ends.
- (2) Measure the length as indicated in the illustration equal between the right and left sides.
- (3) Tighten the lock nut.
Tightening Torque: 38 - 56 N·m (385 - 570 kgf·cm)

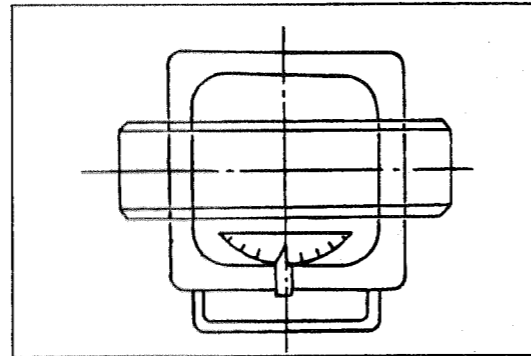

G2FS00018-00017

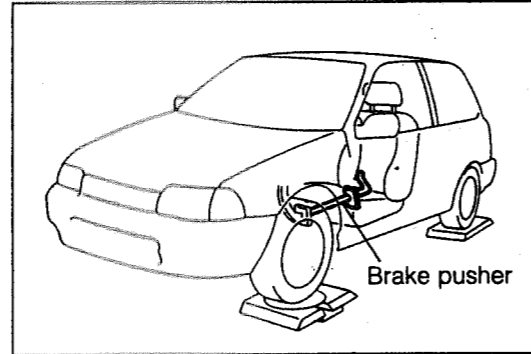

G2FS00019-99999

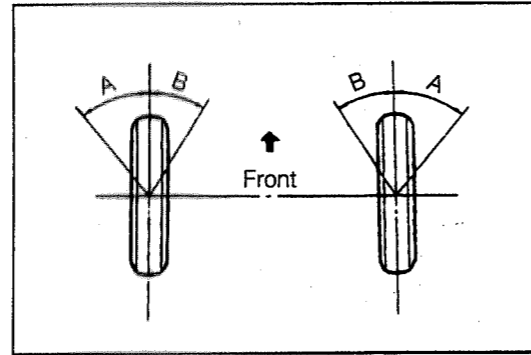

G2FS00020-00019

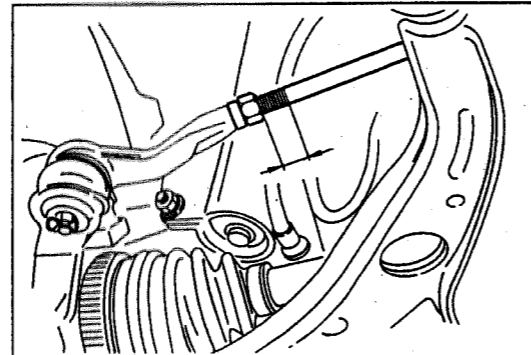

G2FS00021-99999

FRONT AXLE

INSPECTION

1. Inspection of following parts

- ② Front wheel bearing dust deflector ... Deformation
- ④ Steering knuckle Cracks or damage
- ⑤ Disc brake cover sub-assembly Deformation
- ⑥ Wheel bearing Wear or damage
- ⑧ Front axle hub sub-assembly Damage or wear

2. Removal

- (1) Jack up the vehicle.

NOTE:

- Be sure to support the vehicle securely with safety stands.

- (2) Remove the front wheel.
- (3) Remove the attaching bolts of the disc brake caliper.
- (4) Suspend the disc brake caliper.

- (5) Remove the brake disc attaching screw.
- (6) Remove the brake disc from the front axle hub.

NOTE:

- If the brake disc can not be removed readily by hand, use bolts to remove the disc.

3. Inspection of wheel bearing

- (1) Ensure that there is no looseness between the drive shaft and axle hub.
- (2) Perform the axial tolerance measurement at a point of the drive shaft edge with a dial gauge.
- (3) If the tolerance exceeds the allowable limit, replace the wheel bearing.
Axial Tolerance Limit: 0.05 mm

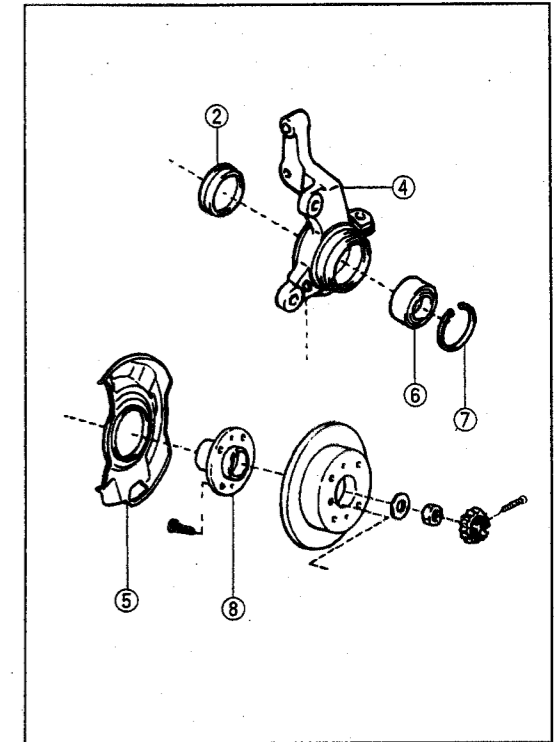

G2FS00022-00020

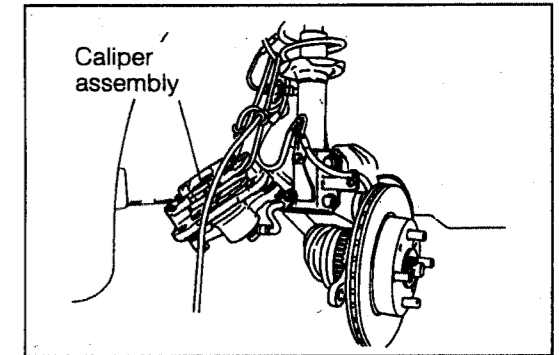

G2FS00023-99999

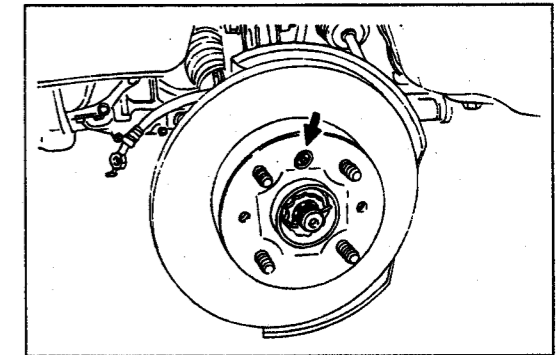

G2FS00024-00022

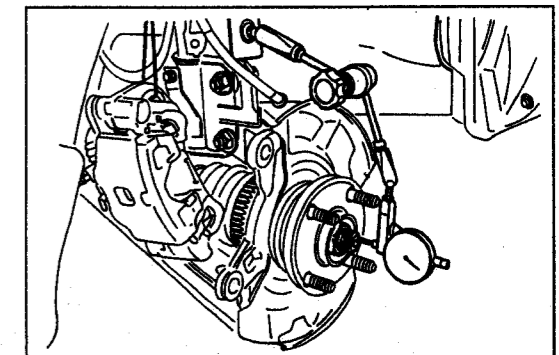

G2FS00025-99999

4. Inspection of axle hub

- (1) Perform the runout measurement at a point of the axle hub outer edge.
- (2) If the runout exceeds the allowable limit, change the axle hub.

Runout Limit: 0.05 mm

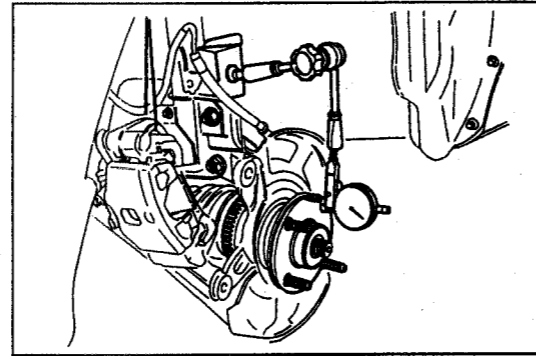

G2FS00026-99999

REMOVAL

1. Separation of tie-rod end

- (1) Remove the cotter pin and castle nut from the tie-rod end.
- (2) Separate the tie-rod end from the steering knuckle, using the following SST.

SST: 09611-87701-000

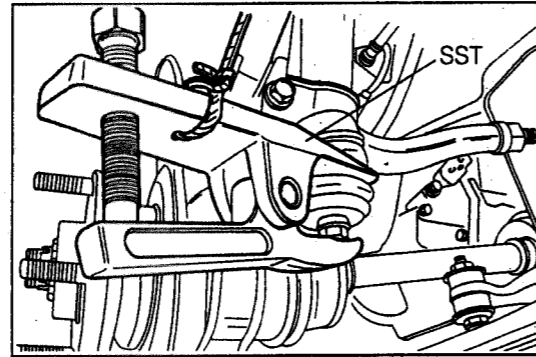

G2FS00027-99999

CAUTION:

- While using the SST, be very careful not to damage the boot and threaded portion.

2. Removal of front axle hub

- (1) Remove the cotter pin and front wheel adjusting lock cap.
- (2) Remove the nut, using the following SST in combination with a 30 mm socket wrench.

SST: 09511-87202-000

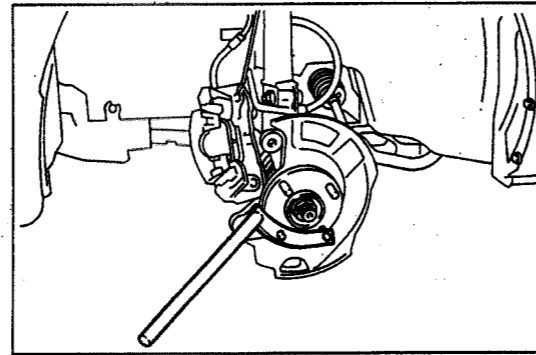

G2FS00028-99999

- (3) Draw out the front axle hub sub-assembly with inner race of bearing, using the following SST.

SST: 09520-00031-000

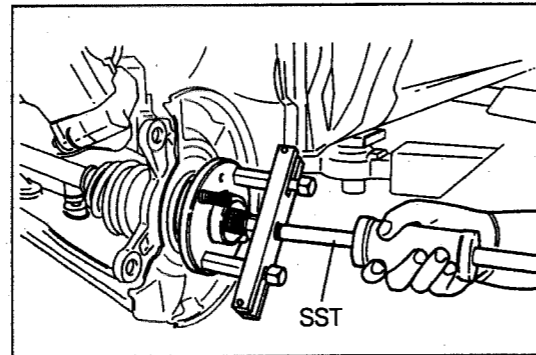

G2FS00029-99999

3. Separation of steering knuckle

- (1) Remove the attaching nuts. Leave the bolts in their inserted conditions.
- (2) Separate the front shock absorber and steering knuckle.
- (3) Disengage the drive shaft from the steering knuckle.

NOTE:

- Protect the drive shaft boot with cloth or the like so that it may not be damaged during the operation.
- Be very careful not to allow the roller of the inboard joint to be detached from the joint outer race.

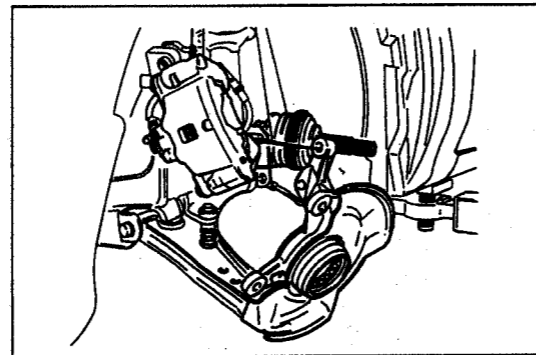

G2FS00030-99999

4. Removal of steering knuckle

- (1) Remove the clip and castle nut from the lower ball joint.
- (2) Separate the suspension lower arm sub-assembly and steering knuckle. Using the following SST.

SST: 09611-87701-000

CAUTION:

- Be certain to use the SST after loosening the castle nut until it becomes flush with the bolt. While using the SST, be very careful not to damage the boot and thread portion.

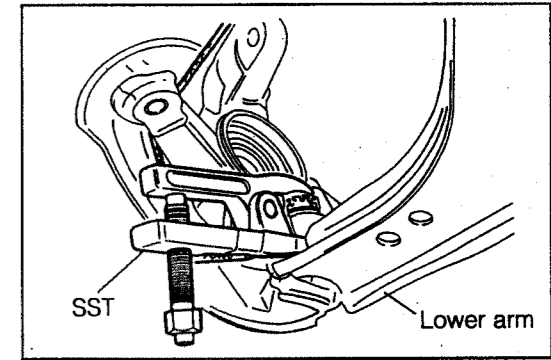

G2FS00031-99999

Replacement

1. Replacement of disc brake cover

- (1) Remove the disc brake cover sub-assembly, using a suitable brass bar or the like.

NOTE:

- Do not remove the disc brake cover unless its replacement is required.

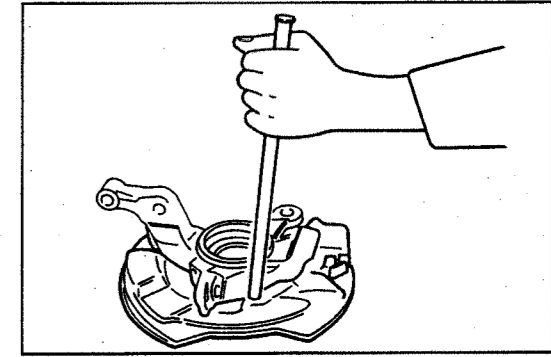

G2FS00032-99999

2. Replacement of front wheel bearing

- (1) Detach the hole snap ring, using a snap ring pliers.

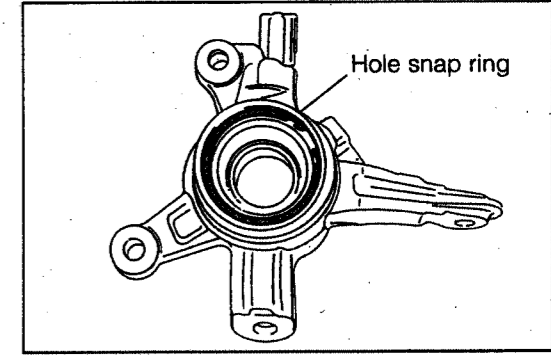

G2FS00033-99999

- (2) Remove the bearing from the steering knuckle, using a press in combination with the following SSTs.

SSTs: 09527-87301-000

09557-10010-000 (Use the 09550-10012-000 that is part of the set.)

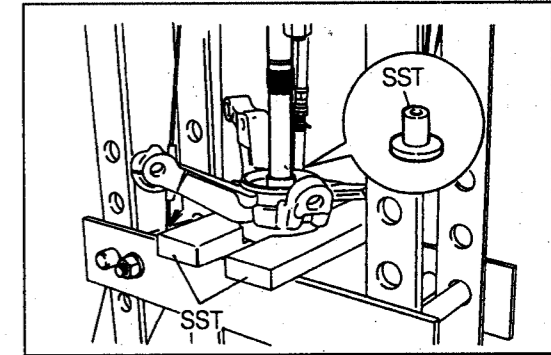

G2FS00034-99999

- (3) Press the new bearing into the steering knuckle, using the SSTs.

SSTs: 09506-87302-000

09554-10010-000

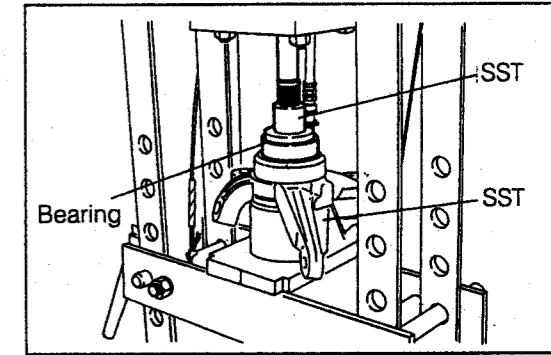

G2FS00035-99999

- (4) Install a new hole snap ring, using snap ring pliers.

- (5) Remove the bearing inner race (outer side) from the front axle hub, using the following SSTs.
 SST: 09950-20017-000
 09608-87501-000

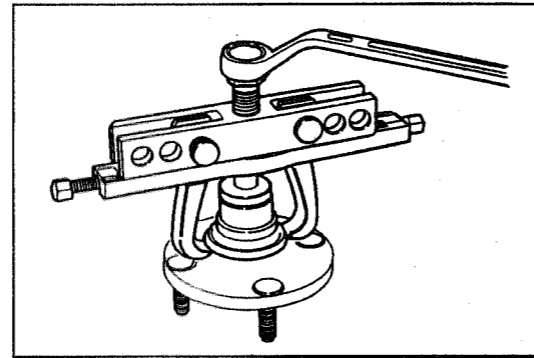

G2FS00036-99999

- (6) Press the disc brake cover until it comes into close contact with the knuckle, using the following SSTs.
 SSTs: 09506-87302-000
 09718-87702-000

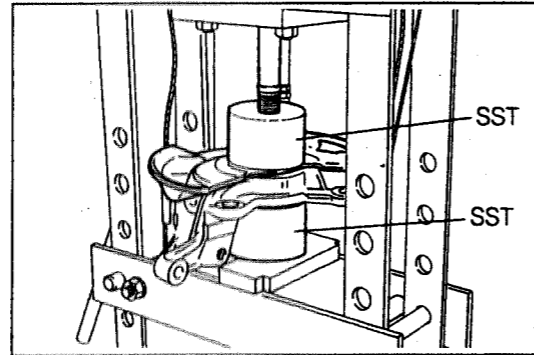

G2FS00037-99999

- NOTE:**
- Make sure that the disc brake cover is press-fitted positively until the cover closely contacts with the knuckle.

- (7) Press the front axle hub into the steering knuckle sub-assembly.
 SST: 09554-10010-000 (Use the 09550-10012-000 that is part of the set.)

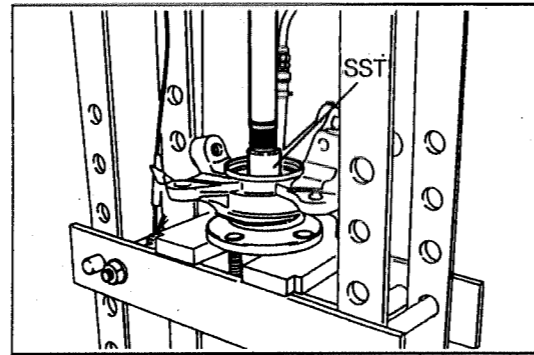

G2FS00038-99999

INSTALLATION

1. Installation of steering knuckle
 (1) Mount the steering knuckle on the lower ball joint of the suspension lower arm.
 (2) Insert the drive shaft to the steering knuckle.

- NOTE:**
- Pay utmost attention not to damage the ball joint dust cover.

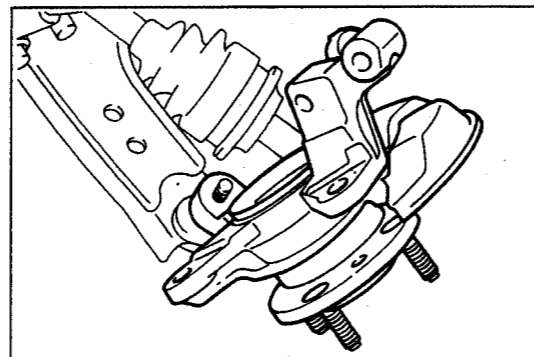

G2FS00039-99999

- (3) Mount the steering knuckle on the shock absorber lower bracket. Tighten the new bolts and new nuts.
 Tightening Torque: 102 - 153 N-m
 (1040 - 1560 kgf-cm)

- NOTE:**
- With the knuckle pushed against the lower side, then tighten the bolts and nuts.

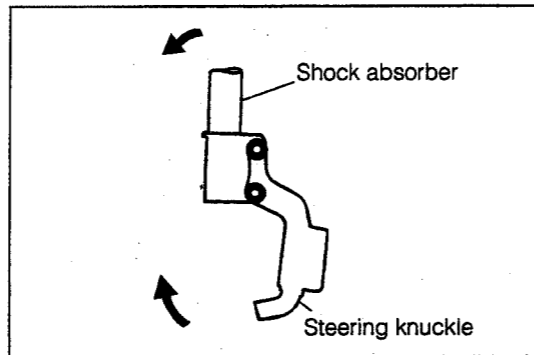

G2FS00040-00038

- (4) Tighten the lower ball joint with new castle nut.
 Tightening Torque: 30 - 44 N-m (300 - 450 kgf-cm)

- NOTE:**
- Make sure that no grease or oil, etc. gets to the taper part of the lower ball joint.

- (5) Install the clip.

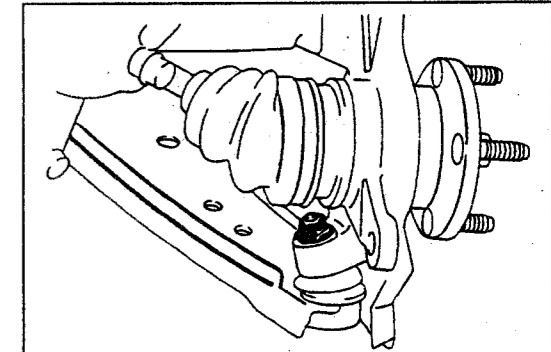

G2FS00041-00039

2. Installation of tie-rod
 (1) Attach the tie-rod end to the steering knuckle and tighten the castle nut.
 Tightening Torque: 25 - 39 N-m (255 - 405 kgf-cm)

- (2) Install a new cotter pin.

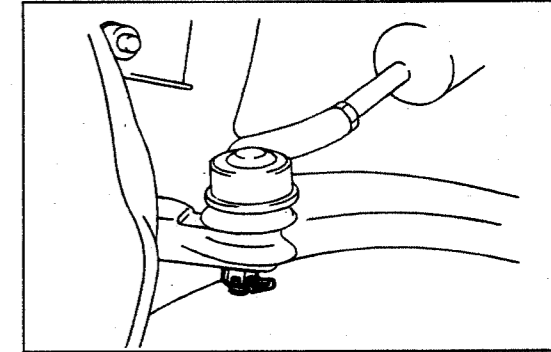

G2FS00042-00040

3. Tightening of drive shaft end nut
 (1) Install the conical washer to the drive shaft.
 (2) Tighten the nut, using the following SST.
 SST: 09511-87202-000
 Tightening Torque: 167 - 226 N-m
 (1700 - 2300 kgf-cm)

- NOTE:**
- When this nut is tightened to the specified torque, the specified pre-load of the front wheel is attained.
 - Be sure to install the conical washer in the correct direction.

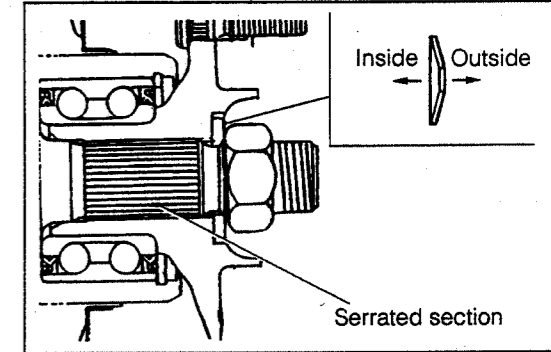

G2FS00043-00041

- (3) Install the front wheel adjusting lock cap to the nut.
 (4) Install a new cotter pin.

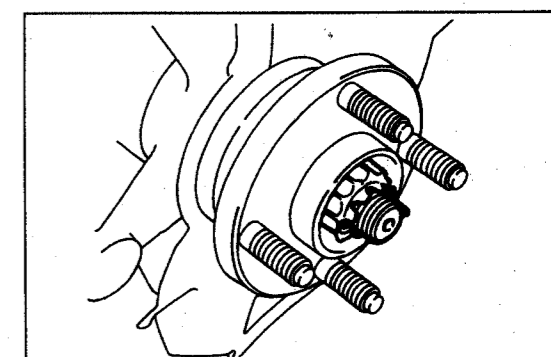

G2FS00044-99999

4. Installation of brake disc.
 (1) Install the brake disc to the front wheel hub.
 (2) Tighten the brake disc attaching screw.
 Tightening Torque: 1 - 3 N-m

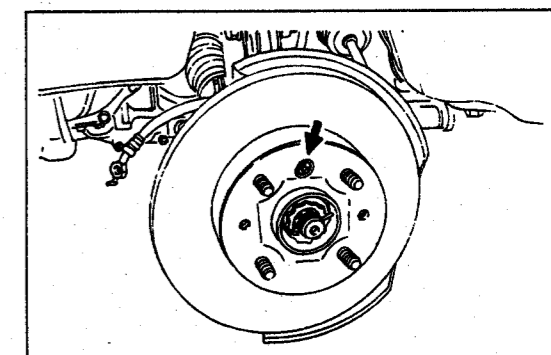

G2FS00045-00022

5. Installation of disk brake caliper assembly
 (1) Install the disc brake caliper to the steering knuckle.
 (2) Tighten the attaching bolts of the disc brake caliper.
 Tightening Torque: 90 - 135 N-m (920 - 1380 kgf-cm)

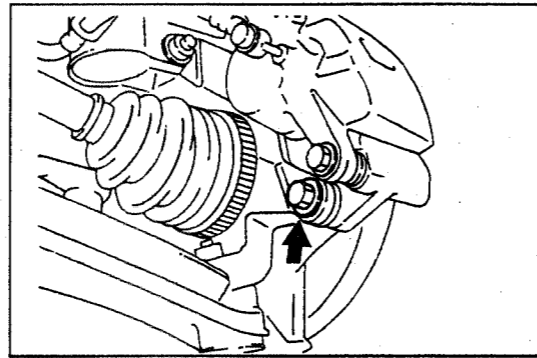

G2FS00046-00044

6. Install the wheel.
 Tightening Torque: 89 - 118 N-m (900 - 1200 kgf-cm)

7. Perform the front wheel alignment inspection and adjustment
 See page FS-2, Wheel alignment

G2FS00047-00000

SHOCK ABSORBER AND SPRING INSPECTION

1. Inspection of following parts

- ⑮ Bush (Strut thrust bearing) Wear
- ⑯ Suspension support assembly Deterioration
- ⑰ Spring upper seat Deterioration or deformation
- ⑱ Bumper Deterioration
- ㉑ Front spring Flattened condition
- ㉒ Shock absorber Noise or operation

2. Removal

- (1) Jack up the vehicle.

NOTE:

- Be sure to support the vehicle securely with safety stands.

- (2) Remove the front wheel.

- (3) Remove the attaching bolt of the brake hose bracket at the shock absorber side.

- (4) Remove the attaching nuts. Leave the bolts in their inserted conditions.

- (5) Remove the attaching nuts of the suspension support at the upper part of the fender.

- (6) Remove the steering knuckle attaching bolts. Draw out the shock absorber from the body.

NOTE:

- Be sure to protect the drive shaft boot with cloth or the like so that it may not be damaged.

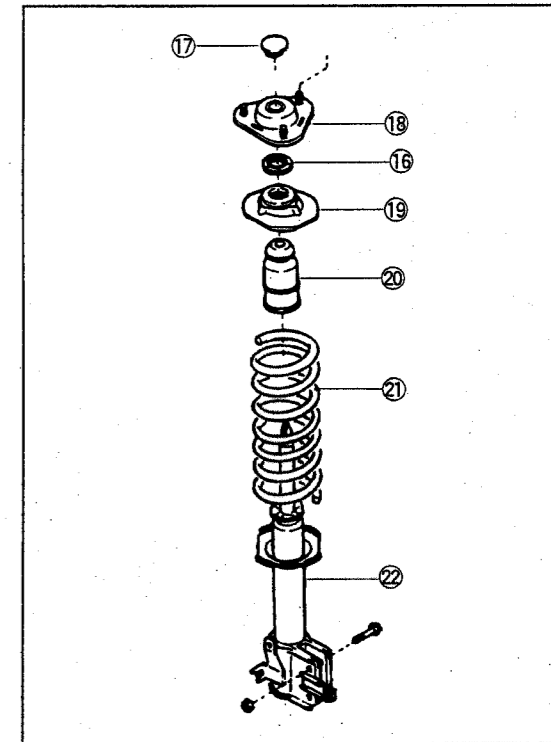

G2FS00048-00045

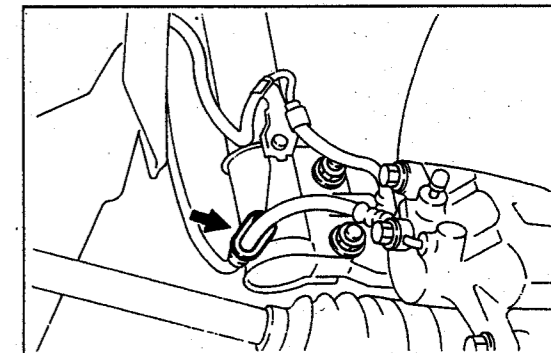

G2FS00049-99999

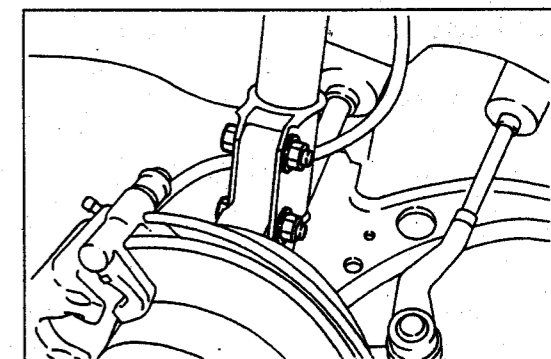

G2FS00050-99999

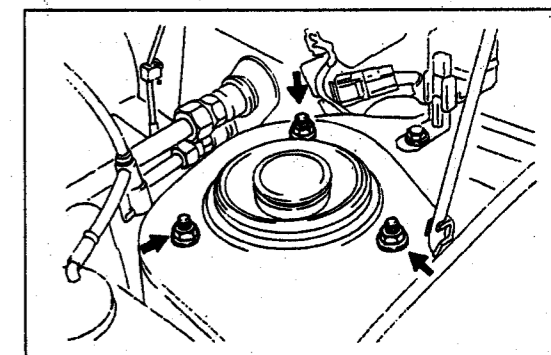

G2FS00051-00048

3. Disassembly

- (1) Compress the coil spring, using the following SST.
SST: 09727-87701-000 or
09727-30020-000

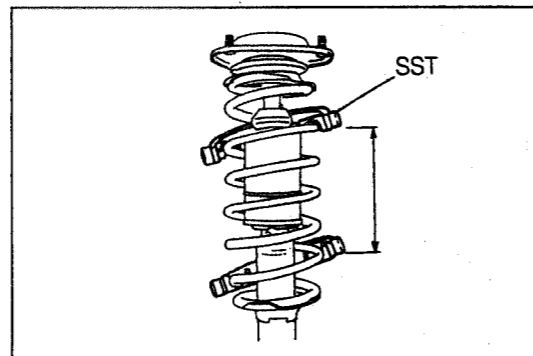

G2FS00052-99999

- (2) Clamp the front suspension support in a vice.
- (3) Remove the bearing dust cover.
- (4) Loosen the nut.

NOTE:

- Never remove the nut by applying impacts on it, using an impact wrench or the like.

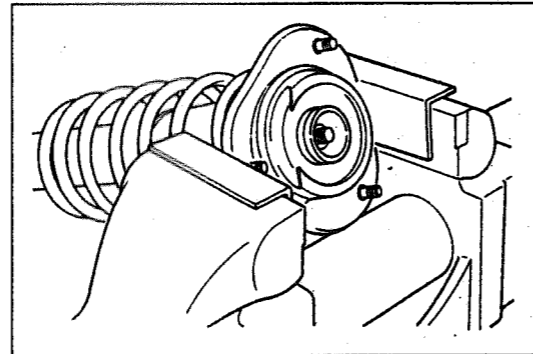

G2FS00053-99999

- (5) Remove the front suspension support.
- (6) Remove the bush and front spring upper seat.
- (7) Remove the coil spring and spring bumper.

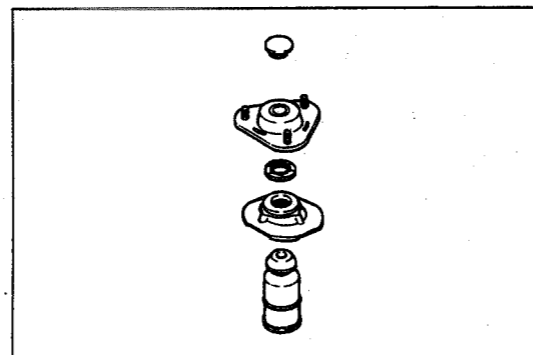

G2FS00054-99999

4. Inspection of shock absorber operation

- (1) While pushing the piston rod, check that the pull through out the stroke is even, and there is no abnormal resistance or noise.
- (2) Push the piston rod in fully and release it. Check that it returns at a constant speed throughout.
- (3) If the absorber operations is defective, replace the absorber, as an assembly.

CAUTION:

- Release the gas completely, before discarding the shock absorber.

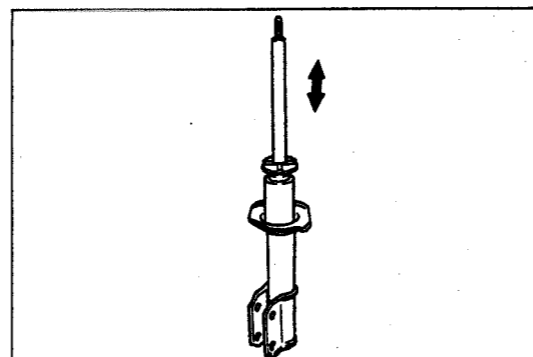

G2FS00055-99999

5. Replacement

- (1) Insert the spring bumper to the piston rod.
- (2) Compress the coil spring, using the following SST.
Install it to the shock absorber.
SST: 09727-87701-000 or
09727-30020-000

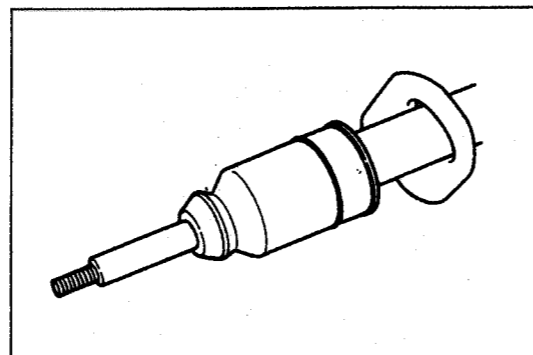

G2FS00056-99999

- (3) Install the front spring upper seat to the shock absorber piston rod.
- (4) Install the bush (thrust) to the front suspension support.

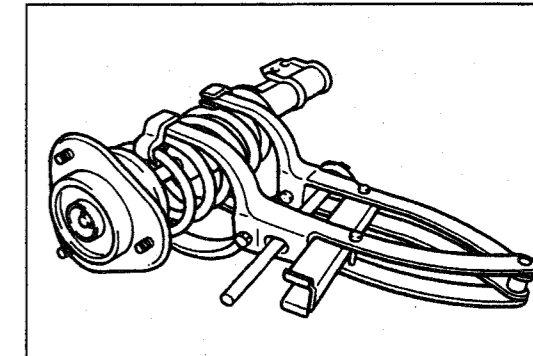

G2FS00057-99999

- (5) Install the front suspension support.

NOTE:

- Be sure to align the cut-out section of the front suspension support with that of the piston rod during the assembly.

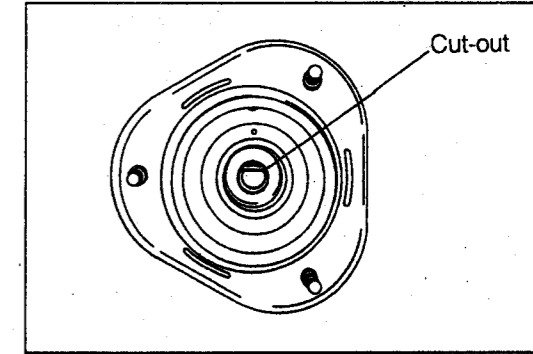

G2FS00058-99999

- (6) Temporarily tighten the piston end nut.

- (7) Clamp the front suspension support in a vice. Tighten the piston end nut, using a new nut.
Tightening Torque: 38 - 56 N·m (385 - 575 kgf·cm)

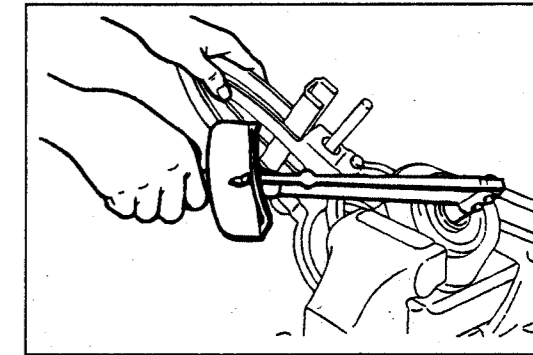

G2FS00059-00056

- (8) Install the bearing dust cover.
- (9) Align the coil spring end with the recessed sections of the upper and lower seats. Proceed to remove the SST.

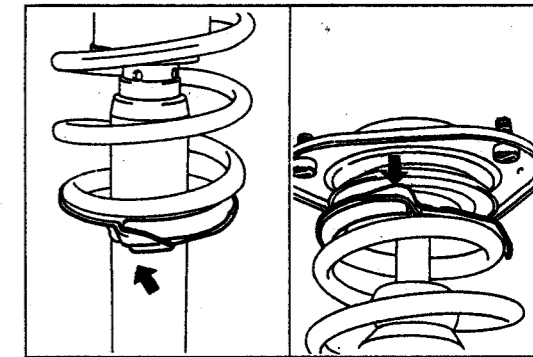

G2FS00060-99999

INSTALLATION

1. Install the suspension support on the fender apron.
(Use new nuts.)
Tightening Torque: 29 - 42 N·m (290 - 430 kgf·cm)

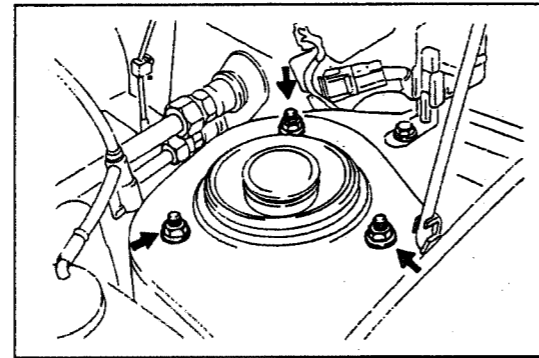

G2FS00061-00048

2. Installation of steering knuckle section
 - (1) Mount the steering knuckle on the shock absorber lower bracket.
 - (2) Install the new bolts and new nuts in place and tighten them.
 Tightening Torque: 102 - 153 N·m
(1040 - 1560 kgf·cm)

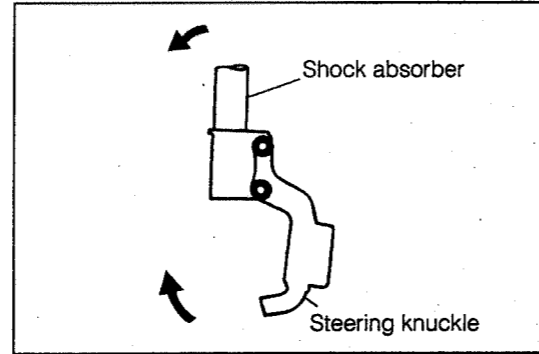

G2FS00062-00038

NOTE:

- With the knuckle pushed against the lower side, tighten the bolts and nuts.

3. Install the brake hose bracket with the bolt to the shock absorber.
4. Install the wheels.
Jack down the vehicle
5. Inspect the front wheel alignment.

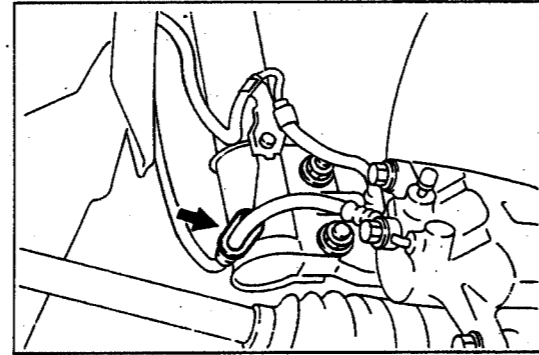

G2FS00063-99999

FRONT STABILIZER BAR

INSPECTION

1. Inspection of following parts

- | | |
|--------------------------------|-------------------------------|
| ⑯ Bush | Deterioration |
| ㉓ Stabilizer bar | Deformation or damage |
| ㉔ Stabilizer bracket | Deformation or damage |
| ㉕ Stabilizer bush | Deterioration |
| ㉖ Stabilizer end bracket | Deformation, cracks or damage |
| ㉗ Stabilizer link rod | Deformation or damage |

2. Removal

- (1) Jack up the vehicle.

NOTE:

- Be sure to support the vehicle securely with safety stands.

- (2) Remove the stabilizer bar end lower nut.
- (3) Remove the stabilizer end bracket from the body by removing the attaching bolt and nut.
- (4) Remove the front stabilizer bar from the body.

- (5) Remove the stabilizer bracket, stabilizer bush and stabilizer end bracket from the stabilizer bar by removing the attaching bolt.
- (6) Remove the stabilizer bush, washer ㉑ and washer ㉒ from the stabilizer link rod.
- (7) Remove the stabilizer link rod from the stabilizer bar.

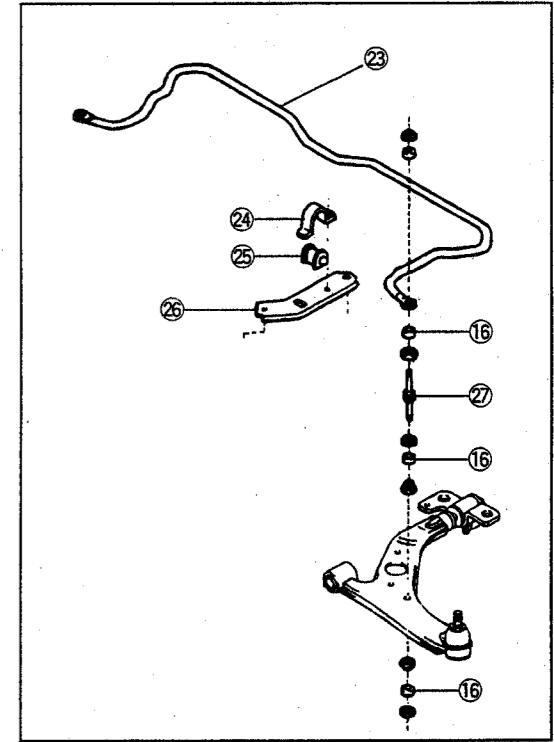

G2FS00064-00058

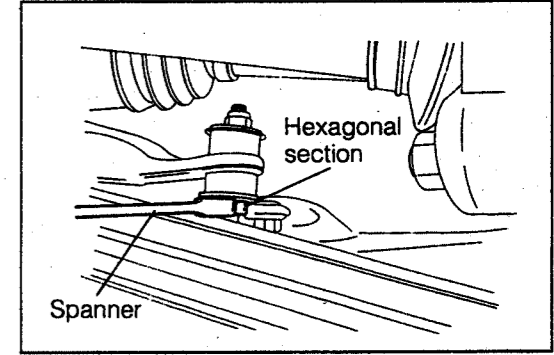

G2FS00065-99999

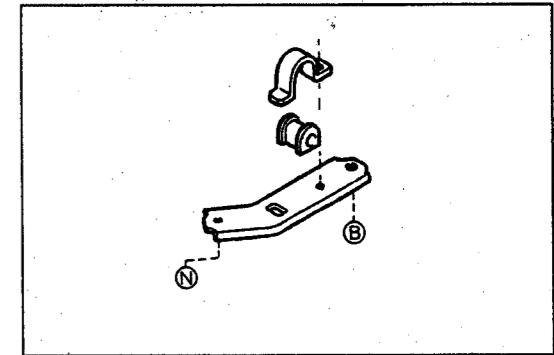

G2FS00066-99999

INSTALLATION

1. Assemble the front stabilizer end bracket, stabilizer bush and stabilizer bracket to the stabilizer bar by means of attaching bolt and new nut.
Tightening Torque: 10 - 15 N·m (100 - 160 kgf·cm)
2. Install the stabilizer rink assembly to the front stabilizer bar end with attaching new bolt.
Tightening Torque: 10 - 15 N·m (100 - 160 kgf·cm)
3. Assemble the stabilizer rink, bush, washer A and B.
4. Install the stabilizer bar end cushions, cushion retainers and bolt to the suspension lower arm, while paying attention to the direction of the cushion retainer.
5. Insert the stabilizer bar end bolt to the suspension lower arm.
6. Tighten them, using new nut.
Tightening Torque: 10 - 15 N·m (100 - 160 kgf·cm)
7. Lower the vehicle.
Rock the front section of the vehicle in an up-and-down direction two or three times so as to settle the suspension.

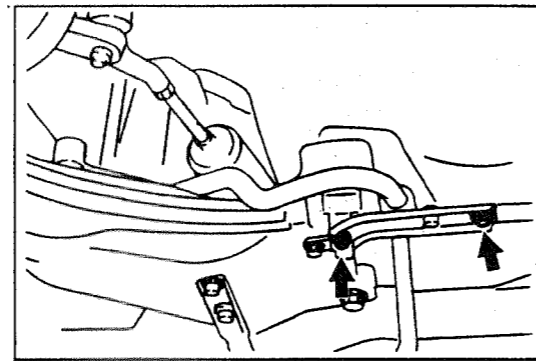

G2FS00067-00061

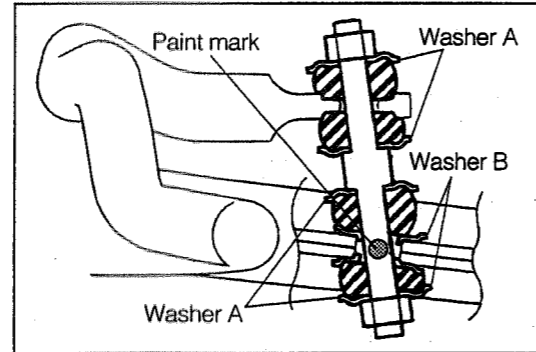

G2FS00068-00062

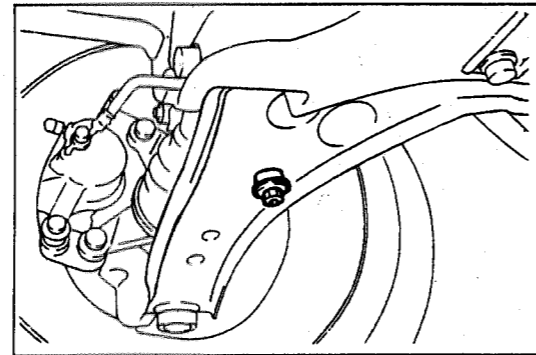

G2FS00069-00063

SUSPENSION LOWER ARM

INSPECTION

1. Inspection of following parts.

- ① Lower arm bracket connecting rod Damage or cracks
- ② Lower control arm cover Damage
- ③ Lower ball joint dust cover Deterioration
- ④ Suspension lower arm sub-assembly Damage or cracks
- ⑤ Lower arm bush Deterioration

2. Removal

- (1) Jack up the vehicle.

NOTE:

- Be sure to support the vehicle securely with safety stands.

- (2) Remove the front wheel.

NOTE:

- Do not perform the following procedure, unless its replacement is required due to the inspection.

- (3) Remove the front stabilizer bar.

- (4) Remove the cotter pin and castle nut from the lower ball joint.

- (5) Separate the suspension lower arm from the steering knuckle, using the following SST.

SST: 09611-87701-000

- (6) Remove the attaching nut of the suspension lower arm at the body side.

- (7) Remove the lower arm bracket by removing the attaching bolts.

- (8) Remove the suspension lower arm.

- (9) Remove the lower arm bracket connecting rod by removing the attaching bolts.

3. Replacement

- (1) Remove the dust cover, using a screwdriver.

NOTE:

- Do not remove the dust cover, unless its replacement is required due to the damage or deterioration.

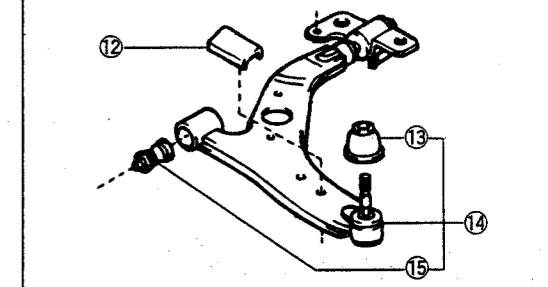
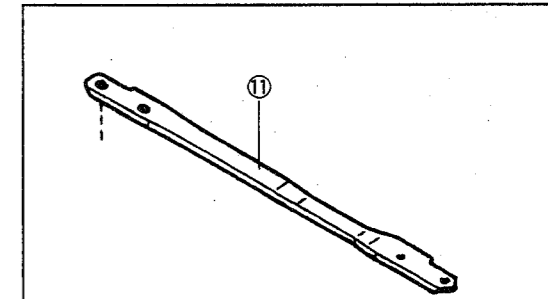

G2FS00070-00064

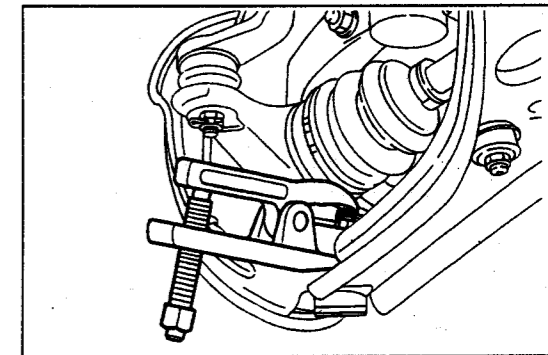

G2FS00071-99999

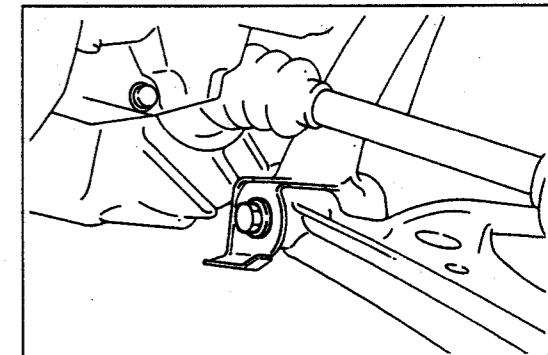

G2FS00072-99999

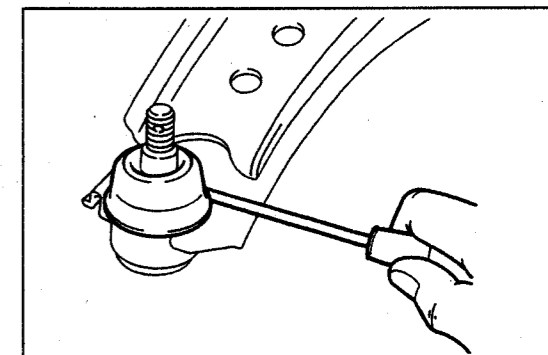

G2FS00073-99999

- (2) Press the new dust cover into position, using a press in combination with the following SST.
SST: 09618-87301-000

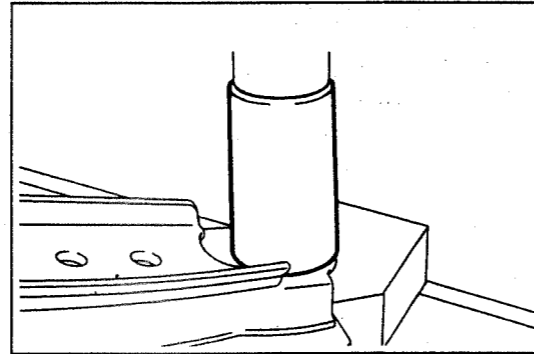

G2FS00074-99999

- (3) Cut the bush periphery edge as shown in illustration.

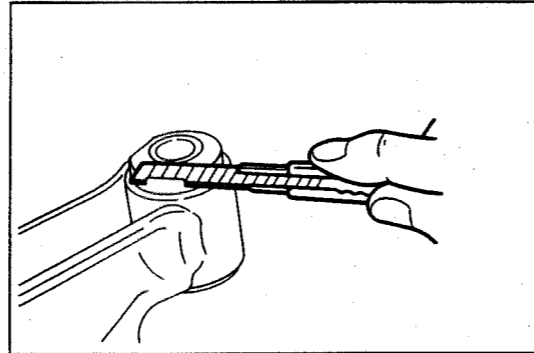

G2FS00075-99999

- (4) Remove the old bush (lower arm front) until it half length of the old bush comes out from the lower arm, using a press in combination with a suitable piece.

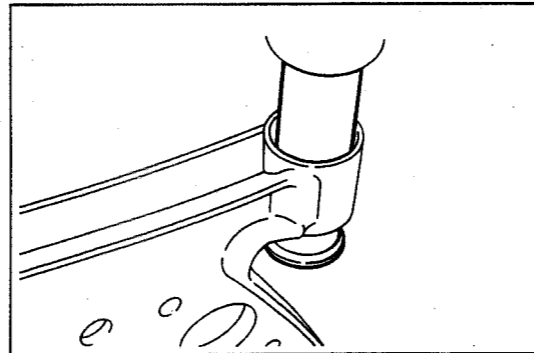

G2FS00076-99999

NOTE:

- Be preventive of tilting while installing the new bush with a press, Use the old bush for a inserting guide of the new bush.

- (5) Insert the old bolt and washer to the new bush.
(6) Press the new bush into position, using a press.

NOTE:

- Apply SUNPAR® liquid to the periphery of the new bush.

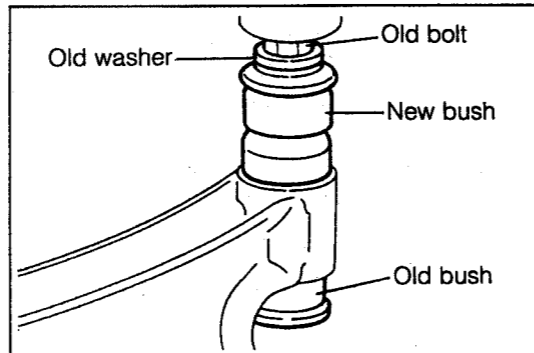

G2FS00077-99999

INSTALLATION

1. Install the lower arm bracket connecting rod with the attaching bolts.
Tightening Torque: 40 - 92 N·m (400 - 940 kgf·cm)

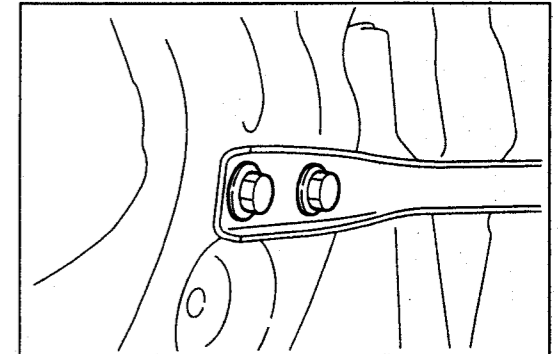

G2FS00078-99999

2. Temporarily tighten with new attaching bolt of the suspension lower arm. (front section)
3. Installation of suspension lower arm rear bracket
(1) Tighten the set bolt.
Tightening Torque: 15 - 32 N·m (145 - 335 kgf·cm)

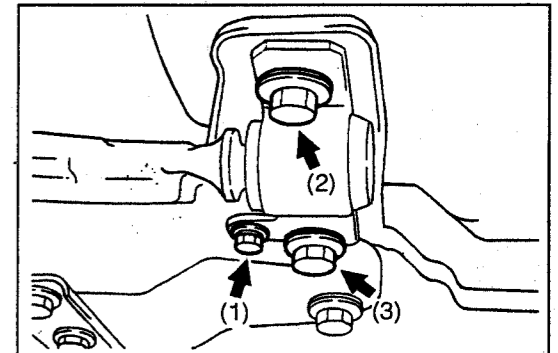

G2FS00079-00073

- (2) Tighten the short bolt.
Tightening Torque: 167 - 245 N·m
(1700 - 2500 kgf·cm)
(3) Tighten the long bolt.
Tightening Torque: 167 - 245 N·m

4. Tighten the attaching bolt. (front section)
Tightening Torque: 167 - 245 N·m
(1700 - 2500 kgf·cm)

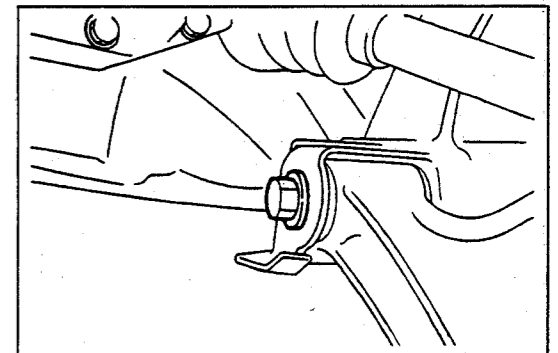

G2FS00080-00074

5. Tighten the nut of the ball joint section.
Tightening Torque: 30 - 44 N·m (300 - 450 kgf·cm)
(Max. 63 N·m for align the cutter pin)

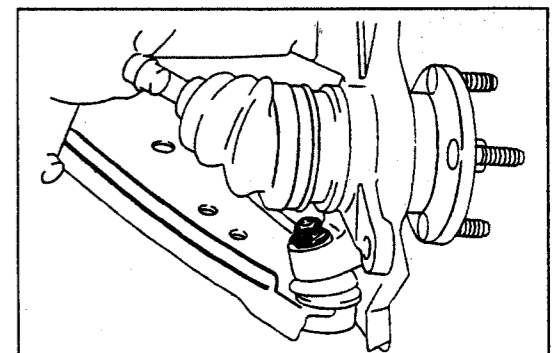

G2FS00081-00039

NOTE:

- Make sure that no grease or oil, etc. gets to the socket section during the tightening operation.

6. Install the front stabilizer bar.
7. Inspection of front wheel alignment.
(1) Install the front wheel.
(2) Lower the vehicle. Rock the front section of the vehicle in an up-and-down direction two or three times so as to settle the suspension.
(3) Inspect the front wheel alignment.

G2FS00082-00000

DRIVE SHAFT & RELATED PARTS

INSPECTION

1. Inspection of following parts

- ① Boot Damage or deterioration
- ② Dynamic damper Damage or deformation
- ③ Inboard joint outer Damage or wear
- ④ Inboard joint assembly Damage or wear
- ⑤ Drive shaft assembly Damage, wear or bend
- ⑥ Inboard joint center Damage or wear

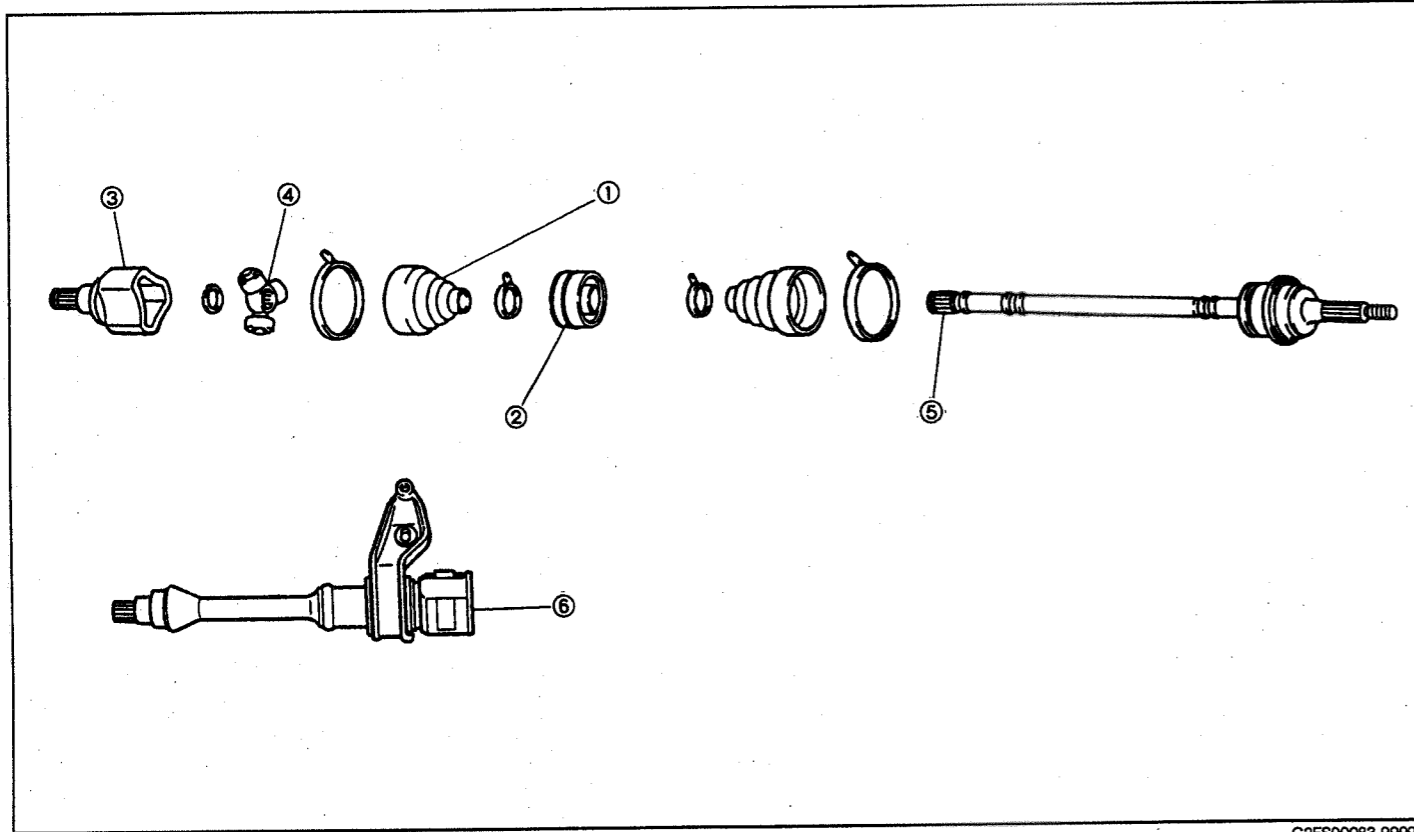

G2FS00083-99999

2. Removal

(1) Jack up the vehicle.

NOTE:

- Be sure to support the vehicle securely with safety stands.

- (2) Remove the front wheels.
- (3) Drain the transmission oil.

G2FS00084-00000

- (4) Pull out the cotter pin of the drive shaft. Remove the castle nut cap.
 - (5) Remove the brake caliper assembly from the knuckle by removing the attaching bolts.
 - (6) Remove the castle nut of the front axle hub, using the following SST.
- SST: 09511-87202-000

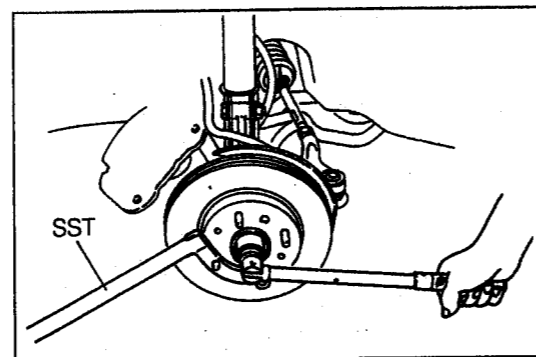

G2FS00085-99999

- (7) Remove the clip and castle nut from the tie-rod end.
 - (8) Separate the tie-rod end from the steering knuckle, using the following SST.
- SST: 09611-87701-000

NOTE:

- While using the SST, be very careful not to damage the boot and threaded portion.

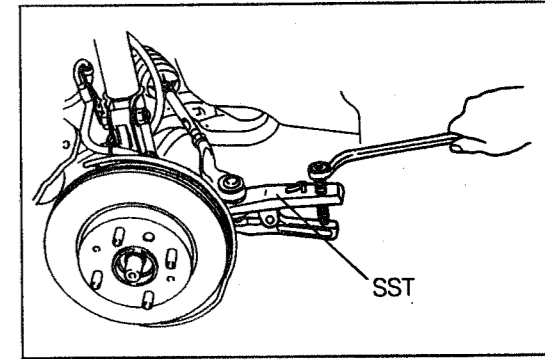

G2FS00086-99999

- (9) Remove the attaching bolt of the brake hose.
- (10) Remove the attaching bolts and nuts of the shock absorber lower bracket.
- (11) Separate the knuckle from the shock absorber lower bracket.
- (12) Leave the drive shaft in their inserted conditions.

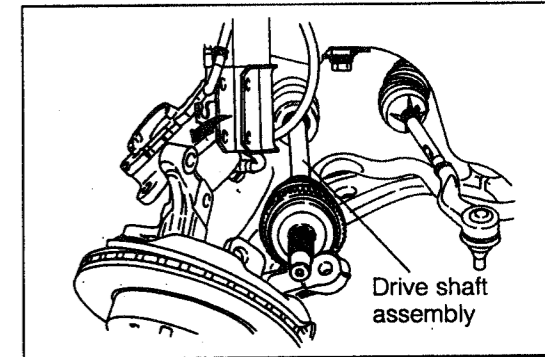

G2FS00087-99999

NOTE:

- For left side of the transmission; Pull out the drive shaft from the transmission, using a crowbar.

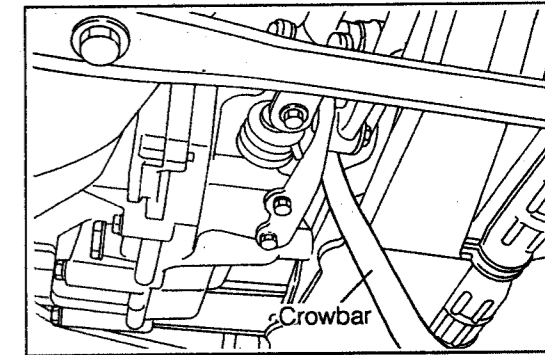

G2FS00088-99999

NOTE:

- For right side of the automatic transmission; Remove the nut and bolt of the alternator bracket. Pull out the drive shaft, using a crowbar.

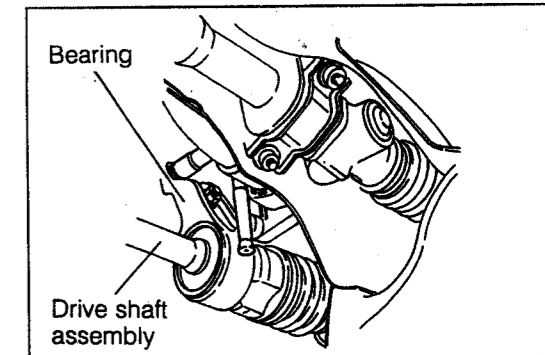

G2FS00089-99999

- For right side of the manual transmission; Pull out the drive shaft, using the following SST.
- SST: 09648-87201-000

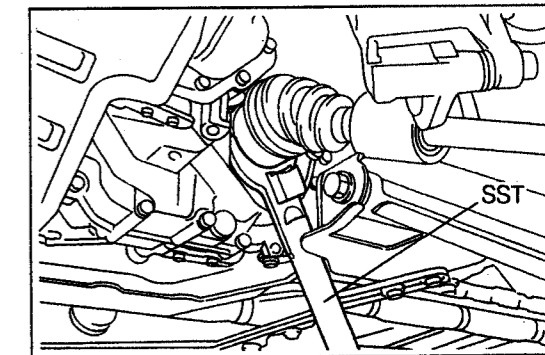

G2FS00090-99999

CAUTION:

- As for the inboard side of the drive shaft, no stopper is provided at the inside. Therefore, be sure to support the inboard joint section of the drive shaft by your hand during the removal.
- To prevent the oil seal at the differential side from being damaged, be certain to support the joint section by your hand so that the joint section may be held horizontally during the removal.

3. Disassembly

(1) Pry up the boot band clip with a screwdriver. Detach the boot.

NOTE:

- Be very careful not to damage the boot.
- On the front drive shaft equipped with front drive bearing shaft, perform the disassembly, following the procedure described in this section. However, it should be noted that the front axle inboard joint and front drive bearing shaft are non-disassembling parts.

(2) Put a mating mark on the front axle inboard joint and shaft, as indicated in the figure. Remove the front axle inboard joint sub assembly.

NOTE:

- Put mating marks with paint. (Never use a punch on the joint or shaft to put mating marks.)

(3) Detach the shaft snap ring, using snap ring pliers.

(4) Removal of inboard joint tripod assembly.

(5) Put a mating mark at the tip end of the inboard joint tripod and shaft, using a punch.

(6) Remove the inboard joint tripod from the shaft.

G2FS00091-00000

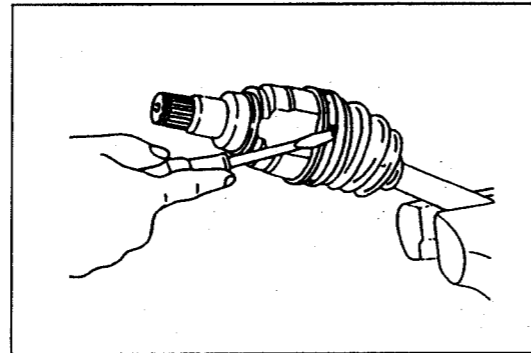

G2FS00092-99999

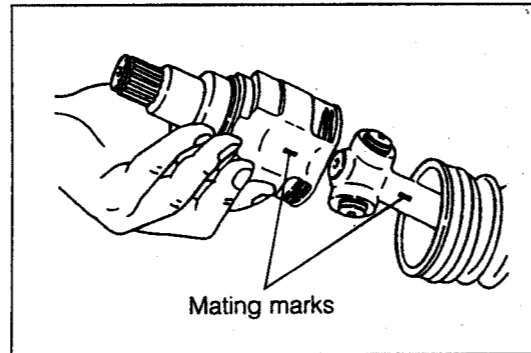

G2FS00093-99999

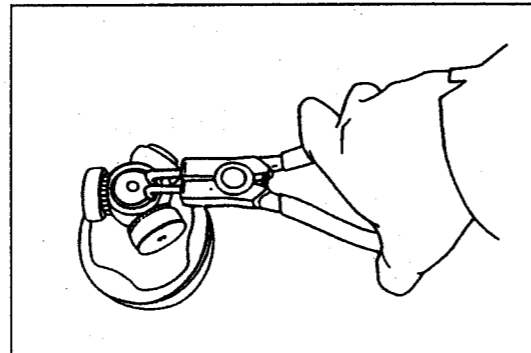

G2FS00094-99999

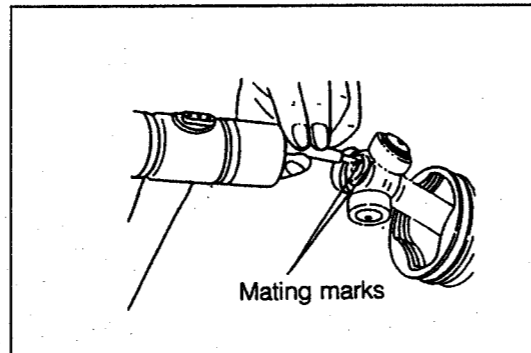

G2FS00095-99999

NOTE:

- If any difficulty is encountered in removing the inboard joint tripod from the shaft, pull it out, using a brass bar.

CAUTION:

- Be sure to apply the brass bar to the inboard joint tripod boss section, not to the roller section.

(7) Pry up the boot band with a screwdriver.

NOTE:

- Be very careful not to damage the boot.

(8) Remove the front axle joint boot from the inboard side.

(9) Remove the dynamic damper with a press. (if dynamic damper is equipped)

NOTE:

- Be sure to clean up completely a dust on the drive shaft.
- Be very careful not to damage the dynamic damper.

(10) Pry up the boot band clip with a screwdriver. Detach the boot.

(11) Remove the front axle joint boot from the outboard side.

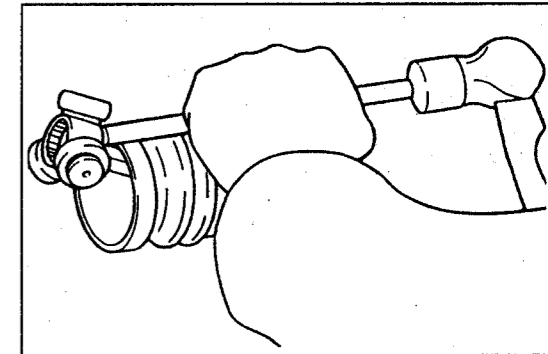

G2FS00096-99999

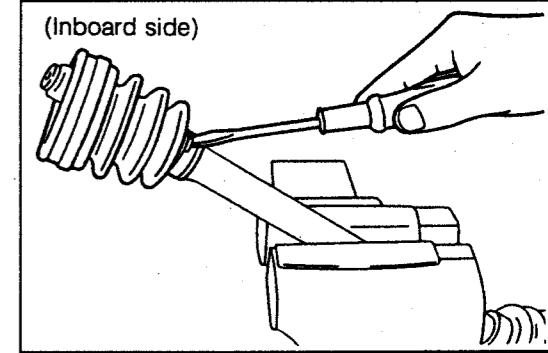

G2FS00097-99999

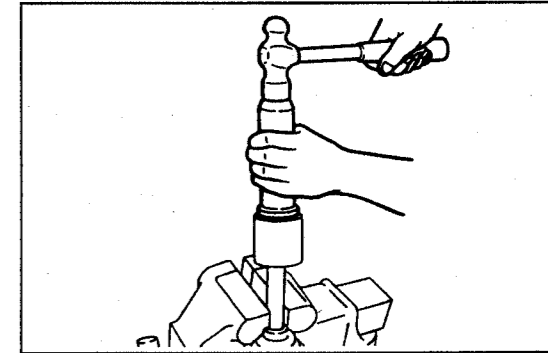

G2FS00098-99999

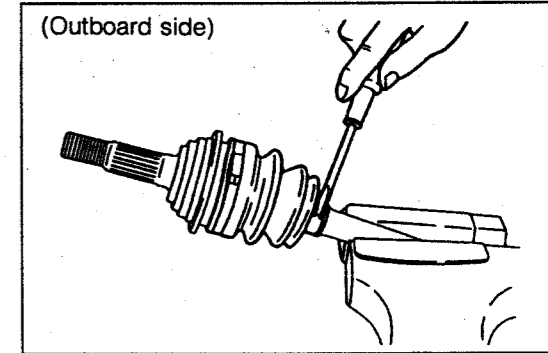

G2FS00099-99999

4. Replacement (Out board joint boot)

- (1) Wind a plastic tape on the splined portion so that the boot may not be damaged during the fitting.
- (2) Insert the boot and a new boot band (shaft side) on the outboard joint.
- (3) Clamp the (drive) shaft portion in a vice.
- (4) Clamp the band at the position.

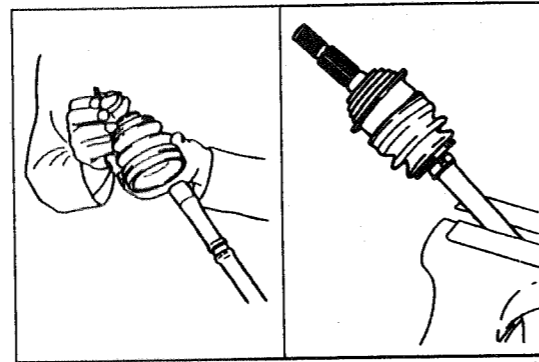

G2FS00100-99999

- (5) Pack the outboard joint section with grease.

NOTE:

- It should be noted that the grease for the outboard joint differs from that for the inboard joint.
- Use the grease that has been furnished along with the boot as a kit.
- Pack the grease as closely to the joint as possible.

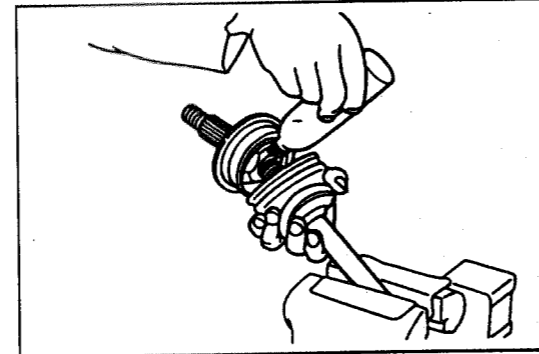

G2FS00101-99999

- (6) Fit a new boot band (Outboard joint outer side) in place.

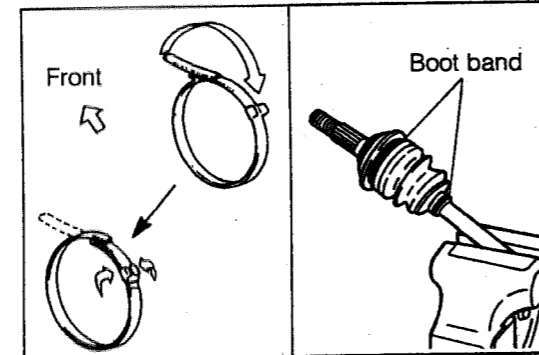

G2FS00102-99999

- (7) Install the dynamic damper, using a press in combination with the following SSTs.

(If dynamic damper is equipped.)

SST: 09309-87201-000

09309-87301-000

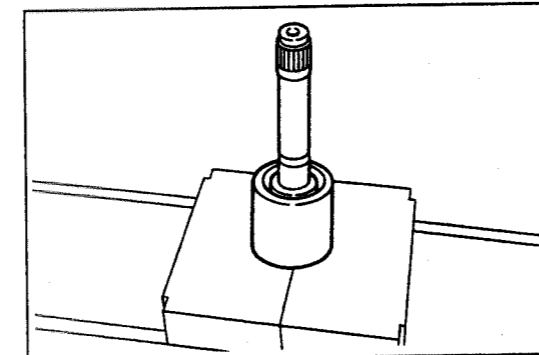

G2FS00103-99999

5. Replacement (Inboard joint section)

- (1) Temporarily install the boot and a new boot band onto the drive shaft.
- (2) Remove the vinyl tape that was wound around the splined portion.

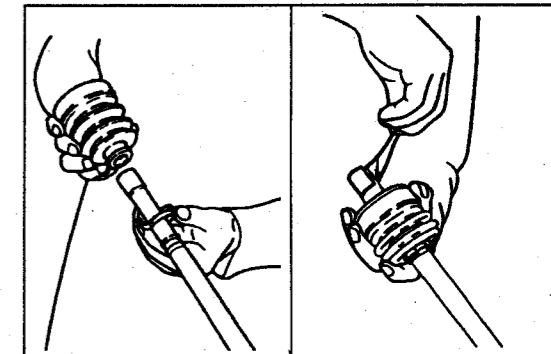

G2FS00104-99999

- (3) Face the non-splined side of the inboard joint tripod toward the outboard joint.

- (4) Align the mating marks which were put during the disassembly.

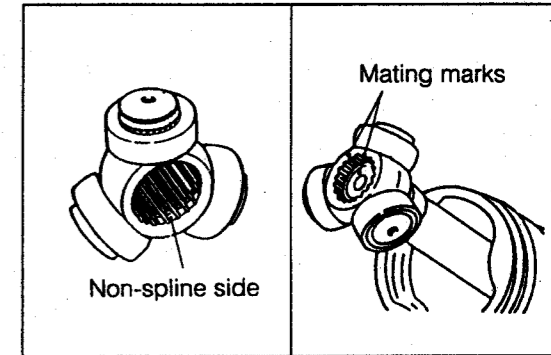

G2FS00105-99999

- (5) Install the tripod assembly onto the shaft.

NOTE:

- If any difficulty in installing the inboard joint tripod assembly is encountered, drive it onto the shaft lightly, using a brass bar.
- Be sure to apply the brass bar to the boss section of the inboard joint tripod, not to the roller section.

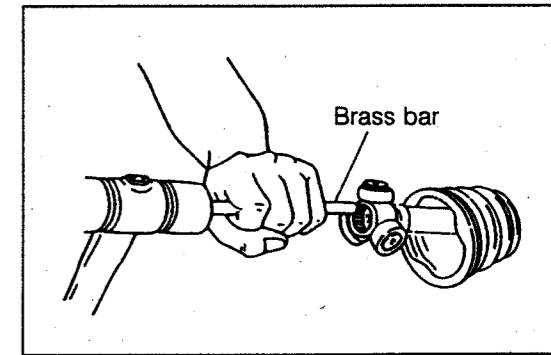

G2FS00106-99999

- (6) Attach the shaft snap ring in position, using snap ring pliers.

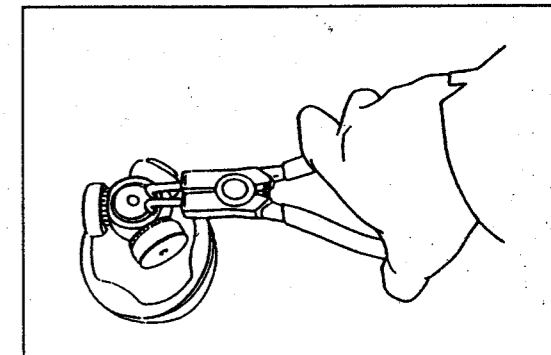

G2FS00107-99999

- (7) Pack the inboard joint section with grease.

NOTE:

- Use the grease that has been furnished along with the boot as a kit.
- Pack the grease as closely to the joint as possible.

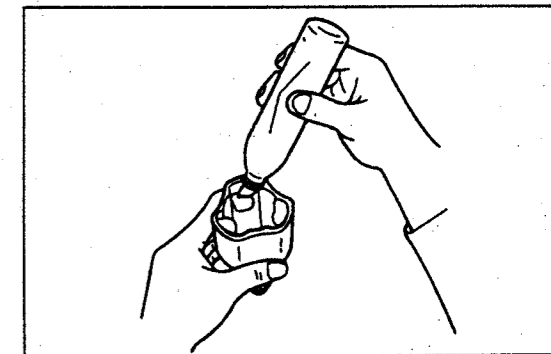

G2FS00108-99999

- (8) Install the front axle inboard joint or front axle inboard joint with front drive bearing shaft, aligning the mating marks which were put during the disassembly.
- (9) Fit new boot bands in place.

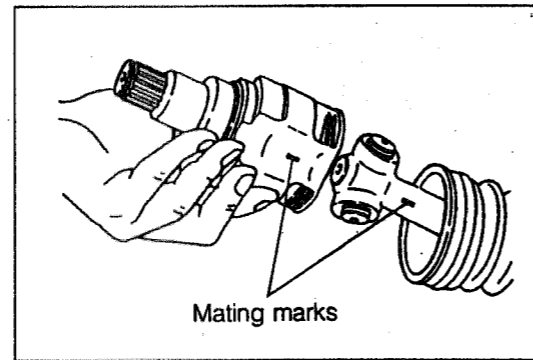

G2FS00109-99999

INSTALLATION

1. Prior to assembling the front drive shaft, check the differential oil seal. Replace the oil seal if it exhibits any defect.
 - (1) Remove the oil seal, using a screwdriver.
 - (2) Drive the oil seals into position, using the following SSTs.

SSTs: 09517-87701-000 (M/T, right side)
09517-87702-000 (M/T, left side)

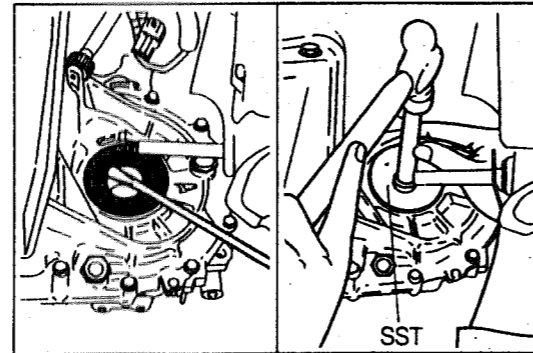

G2FS00110-99999

2. Assembly of front drive shaft
 - (1) Insert the inboard joint section of the front drive shaft into the transmission.

NOTE:

 - Apply MP grease to the oil seal lip section of the transmission.
 - Be very careful not to damage the oil seal during the installation.

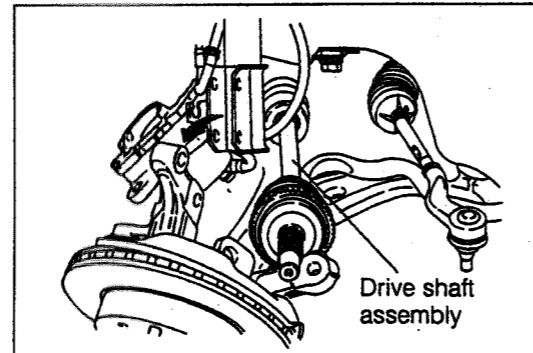

G2FS00111-99999

- (2) Apply chassis grease to the whole serrated section of the front drive shaft at the outboard joint side.
 - (3) Insert the outboard joint section into the knuckle. Temporarily retain the drive shaft with the conical washer and nut.

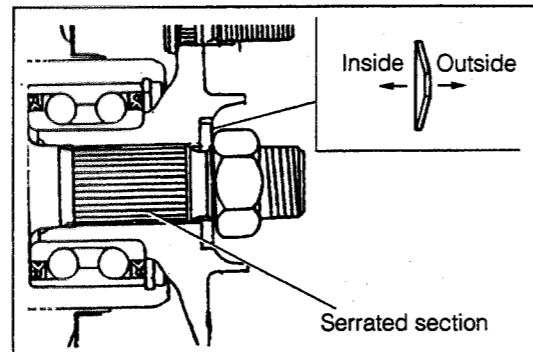

G2FS00112-00041

3. Installation of knuckle
 - (1) Mount the front axle hub assembly on the shock absorber lower bracket.
 - (2) Install the new bolts and new nuts in place and tighten them.

Tightening Torque: 102 - 153 N·m
(1040 - 1560 kgf·cm)

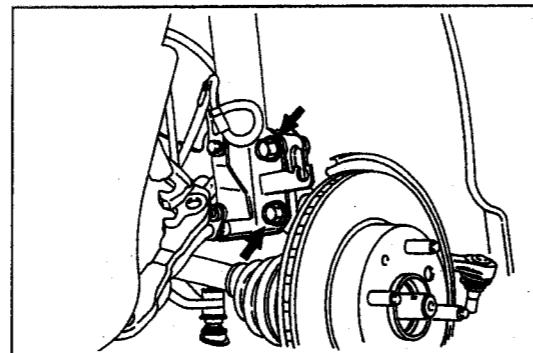

G2FS00113-99999

4. Installation of tie-rod end
 - (1) Attach the tie-rod end to the steering knuckle and tighten the castle nut.

Tightening Torque: 30 - 44 N·m (300 - 450 kgf·cm)

 - (2) Install a new clip.

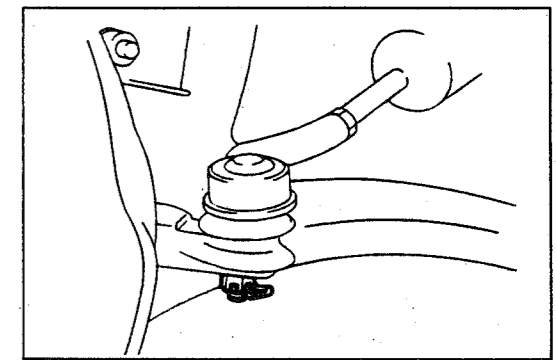

G2FS00114-00040

5. Tightening of nut, using the following SST
 - (1) Tighten the nut.

SST: 09511-87202-000

Tightening Torque: 167 - 226 N·m
(1700 - 2300 kgf·cm)

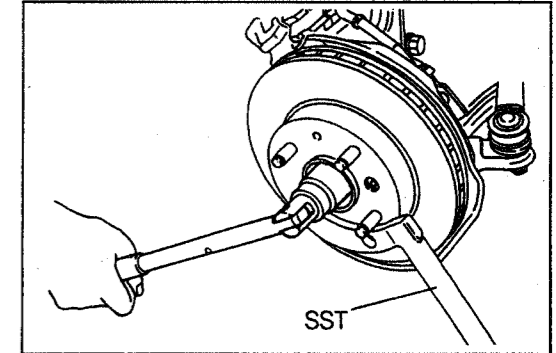

G2FS00115-99999

NOTE:

- When this nut is tightened to the specified torque, the specified pre-load of the front wheel is attained.

- (2) Install the front wheel adjusting lock cap to the nut.
- (3) Install a new cotter pin.

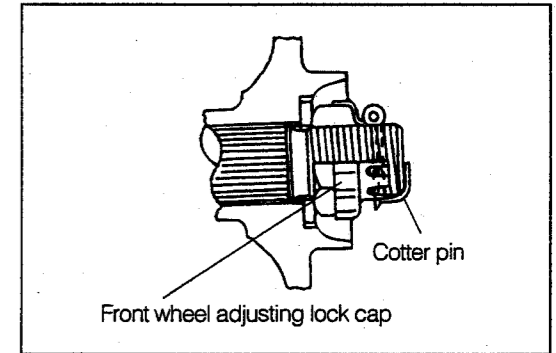





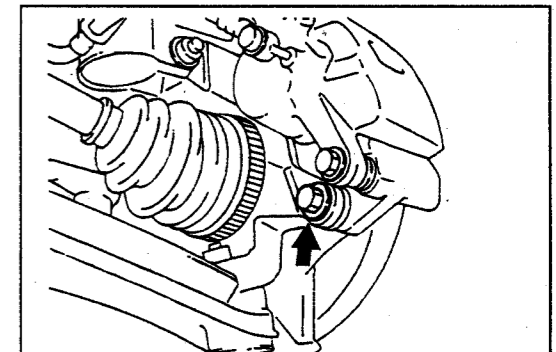



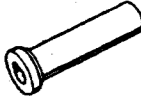

G2FS00116-00103

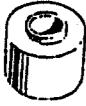
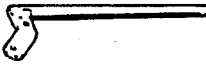
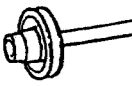

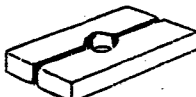

6. Install the disc brake caliper to the knuckle.
- Tightening Torque: 90 - 135 N·m (920 - 1380 kgf·cm)
7. Install the wheel.
 8. Inspection and adjustment of front wheel alignment

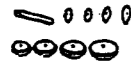

G2FS00117-00044

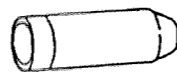
SSTs

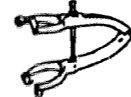
Shape	Part No.	Part name
	09309-87201-000	Replacer, Transmission bearing
	09309-87301-000	Replacer, Transmission bearing
	09506-87302-000	Replacer, Deferential drive pinion bearing cone
	09511-87202-000	Stopper, Brake drum
	09517-87701-000	Replacer, Oil seal (Case side, M/T)
	09517-87702-000	Replacer, Oil seal (Housing side, M/T)
	09520-00031-000	Puller, Rear axle shaft
	09527-87301-000	Remover, Rear axle shaft bearing
	09550-20012-000	Puller, Universal
	09554-10010-000 (09650-10012-000)	(Replacer set, B: 09550-10012-000)
	09557-10010-000 (09650-10012-000)	(Replacer set, B: 09550-10012-000)
	09608-87501-000	Tool set, Axle hub & drive pinion bearing
	09611-87701-000	Puller, Tie-rod end

Shape	Part No.	Part name
	09618-87301-000	Replacer, transmission bearing
	09648-87201-000	Replacer, drive shaft
	09718-87702-000	Replacer, Front disc brake dust cover
	09727-87701-000	Compressor, Front coil spring (The alternative SST is 09727-30020-000)
	09950-20017-000	Puller, Universal

TIGHTENING TORQUE

Tightening components	Tightening torque		
	N-m	kgf-cm	ft-lb
Brake disc × Front axle hub	1 - 3	10 - 30	0.7 - 2.2
Disc brake caliper × Steering knuckle	90 - 135	920 - 1380	66.5 - 99.8
Drive shaft × Front axle hub	167 - 226	1700 - 2300	123 - 166
Lower arm bracket connecting rod × Suspension member	40 - 92	400 - 940	28.9 - 68.0
Shock absorber piston end × Suspension support	38 - 56	385 - 575	27.8 - 41.6
Stabilizer end bracket × Body	10 - 15	100 - 160	7.2 - 11.6
Stabilizer link × Suspension lower arm	10 - 15	100 - 160	7.2 - 11.6
Steering knuckle × Shock absorber lower bracket	102 - 153	1040 - 1560	75.2 - 120
Steering knuckle × Tie-rod end sub-assembly	25 - 39	255 - 405	18.5 - 29.4
Suspension lower arm (ball joint) × Steering knuckle	30 - 44	300 - 450	21.7 - 32.5
Suspension lower arm (Front) × Body	167 - 245	1700 - 2500	123 - 181
Suspension lower arm rear bracket (Large bolts) × Body	167 - 245	1700 - 2500	123 - 181
Suspension lower arm rear bracket (Small bolt) × Body	15 - 32	145 - 335	10.5 - 24.3
Suspension support × Body front fender	29 - 42	290 - 430	21.0 - 31.1
Wheel disc × Front axle hub	89 - 118	900 - 1200	65.1 - 87.0

G2FS00119-00000

SERVICE SPECIFICATIONS

		Specification
Wheel	Run-out of tire	2 mm for Right-and-Left. 1.4 mm for up-and-down
	Bearing looseness	Axial direction: Tolerance limit 0.05 mm
Wheel alignment	Camber angle	0°20' $\begin{smallmatrix} +40' \\ -20' \end{smallmatrix}$
	Caster angle	1°55' $\begin{smallmatrix} +1' \\ -20' \end{smallmatrix}$
	King-pin angle	12° ± 30'
	Toe-in	1 ± 1 mm
	Wheel turning angle	Inner
Outer		34°30' ± 2°

G2FS00120-00000