

DAIHATSU

G202

GI

CB-Engine

GENERAL INFORMATION

IMPORTANT SAFETY NOTICE	GI- 2
HOW TO USE THIS MANUAL	GI- 4
TOWING INFORMATION	GI- 8
JACKING POINTS & SUPPORTING POINT OF SAFETY STANDS	GI- 9
GENERAL SERVICE INSTRUCTION	GI-10
HANDLING INSTRUCTIONS ON CATALYTIC CONVERTER-EQUIPPED VEHICLES	GI-14
MODEL VARIATION	GI-15
CHASSIS SERIAL NUMBER STAMPED POSITION	GI-16
MANUFACTURE'S PLATE POSITION	GI-16
ENGINE NUMBER AND ENGINE TYPE STAMPED POSITIONS	GI-17
BODY COLOR INFORMATION	GI-17
TRIM CODE	GI-17

G2GI00001-00000

NO. 9188

IMPORTANT SAFETY NOTICE

The vehicle is a machine comprising a great number of parts. Basically speaking, the vehicle is potentially hazard. However, one can handle it safely if he has the required knowledge.

Correct service methods and repair procedures are very vital for assuring not only the safety and reliability of a vehicle, but also the safety of service personnel concerned.

The methods and procedures contained in this manual describe in a general way the techniques which the manufacturer has recommended. Thus, they will contribute to ensuring the reliability of the products. The contents of the servicing operations come in a wide variety of ways. Moreover, techniques, tools and parts necessary for each operation are different widely from each other.

This manual does not cover all details of techniques, procedures, parts, tools and handling instructions which are necessary for these operations, for such coverage is impossible. Hence, any one who obtains this manual is expected first to make his responsible selection as to techniques, tools and parts which are necessary for servicing the vehicle concerned properly. Furthermore, he must assume responsibility for his actions in connection with his own safety.

Therefore, one should not perform any service if he is not capable of making responsible selection and/or if he can not understand the contents herein described, for this manual has been prepared for experienced service personnel.

WARNINGS, CAUTIONS AND NOTES

All these symbols have their specific purposes, respectively.

WARNING:

- This symbol means that there is the possibility of personal injury of the operator himself or the nearby workers if the operator fails to follow the operating procedure prescribed in this manual.

CAUTION:

- This symbol means that there is the possibility of damage to the component being repaired if the operator fails to follow the operating procedure prescribed in this manual.

NOTE:

- To accomplish the operation in an efficient manner, additional instructions concerning the operation are given in this section.

The following list describes general WARNINGS:

- Always wear safety glasses for eye protection.
- Use safety stands whenever a procedure requires you to be under the vehicle.
- Be sure that the ignition switch is always in the OFF position, unless otherwise required by the procedure.
- Set the parking brake when working on the vehicle.
- Operate the engine only in a well-ventilated area to avoid the danger of carbon monoxide.
- Keep yourself and your clothing away from moving parts, when the engine is running, especially from the fan and belts.
- To prevent serious burns, avoid contact with hot metal parts such as the radiator, exhaust manifold, tail pipe, catalytic converter and muffler.
- Do not smoke while working on a vehicle.
- To avoid injury, always remove rings, watches, loose hanging jewelry, and loose clothing before beginning to work on a vehicle.
- Keep hands and other objects clear of the radiator fan blades! The electric cooling fan is mounted on the radiator and can start to operate at anytime by a rise in coolant temperature or turning ON of the air conditioner switch in the case of vehicles equipped with an air conditioner. The electric cooling fan is also mounted on the condenser for air conditioner and starts to operate anytime when the air conditioner switch is turned "ON". For this reason care should be taken to ensure that the electric cooling fan motor is completely disconnected when working under the hood.

G2GI0002-00000

The UNITS used in this manual are showed as the SI UNIT (International System of Unit), and alternatively showed in the metric system and pound system.

"Example"

24.5 - 34.3 N·m (2.5 - 3.5 kgf-m, 18.1 - 25.3 ft-lb)

G2GI0003-00000

YOU SHOULD OBSERVE THE FOLLOWING WARNING WHEN WORKING ON THE VEHICLE AS LAID DOWN BY THE HEALTH AND SAFETY EXECUTIVE.

THE DANGER

Some vehicle parts contain asbestos. Working with them can create dust. Breathing this dust is harmful. Cases of asbestos related cancer have been reported in garage workers.

The dangerous jobs are:

- cleaning brake assemblies
- cleaning clutch housings
- grinding brake linings
- drilling brake linings
- sweeping floors

Brake and clutch linings and disc pads may contain asbestos. If in doubt assume that they do.

WHO IS AT RISK?

Anyone in the garage could be at risk. There is no known safe level of asbestos dust. But the more dust you breath, the greater the chance of lung damage.

The problem is that the dust particles are too small to be seen by the naked eye. And the diseases caused can take years to develop.

Don't put the brakes on your life. Avoid breathing asbestos dust. Prevent dust getting into the air. Follow the WARNING.

WARNING

1. DON'T blow dust out of brake drums or clutch housings with an air line.
2. DO use properly designed drum cleaning equipment which prevents dust escaping
or
use clean wet rags to clean out drums or housings.
Put used rags in a plastic waste bag while still wet.
3. DON'T grind or drill linings unless the machine has exhaust ventilation or there is a ventilated booth to do the work in.
4. DON'T use brushes to sweep up dust.
5. DO use a special vacuum cleaner to remove dust.
6. DO wet dust *thoroughly* and scrape it up if you haven't got a vacuum.
7. DO wear the protective clothing, such as overalls, provided by your employer.
8. DON'T take the protective clothing home. It should be cleaned by your employer.
9. DON'T use equipment if it is not maintained and checked. Ask to see the examination reports for ventilation systems.

G2GI0004-00000

HOW TO USE THIS MANUAL

CONTENTS OF EXPLANATION

1. Schematic Diagram of Components

- (1) The schematic diagram of components that appears at the beginning of each section describes the nomenclature and installed conditions of each component. Furthermore the tightening torque is posted in the figure.
- (2) Those parts whose reuse is not permitted bear a "★" mark for an identification purpose. Be certain to replace these parts with new ones during the assembly.
- (3) During the assembly, be sure to apply grease to those parts indicated by the  mark in the figure.

(Example)

T : Tightening torque
Unit : N·m (kgf·m, ft·lb)
★ : Non-reusable parts

T : 8.7 - 13.0
(1.2 - 1.8, 11.8 - 17.7)

- ① Brake master cylinder assembly
- ② Reservoir tank filler cap
- ③ Reservoir tank cap spacer
- ④ Reservoir tank diaphragm
- ⑤ Switch operating float
- ⑥ Master cylinder reservoir tank subassembly
- ⑦ Clamp
- ⑧ Set bolt
- ⑨ Gasket
- ⑩ Gasket
- ⑪ Master cylinder repair kit

G2GI00005-99999

2. Servicing Procedure

- (1) In principle, the servicing procedure is described in the following sequence given below: Removal → Inspection → Installation, and Disassembly → Inspection → Assembly.
- (2) The explanation covers detailed servicing methods, specifications and notes.
- (3) The main point of each item explains the servicing section and servicing procedure, using illustrations.

(Example)

What to do	How to do it
3. Brake tube installation	
(1) Install the brake tube to the wheel cylinder temporarily by hands.	
(2) Tighten the brake tube to the wheel cylinder, using the following SST.	
SST: 09751-36011-000	

G2GI00006-99999

- (4) The inspection in this manual describes only checking operation. Therefore, if you find any malfunction, replace any defective parts with new ones.

3. SST

For those operations which require the use of any SST, the SST numbers concerned are given in bold letters. Also, a table of all SSTs is collectively posted in the Appendix Data A.

4. Service Specifications

Service specifications are indicated in bold letters or enclosed by heavy lines. Be certain to confirm the specifications concerned. Service specifications are collectively posted in the Appendix Data B.

5. Tightening Torque

For those operations which require the control of tightening torque, the relevant tightening torque is given in bold letters. Be certain to confirm the tightening torque concerned. Tightening torque specifications are collectively posted in the Appendix Data C.

6. Definitions of Terms

Specified Value A value which represents the allowable range during the inspection and adjustment.

Limit A maximum or a minimum limit which the value should not exceed or fall below.

WARNING, CAUTION & NOTE:

All these symbols are indicated in bold letters.

WARNING:

This symbol means that there is a possibility of personal injury of the operator himself or the nearby workers if the operator fails to follow the operating procedure prescribed in this manual.

CAUTION:

This symbol means that there is a possibility of damage to the component being repaired if the operator fails to follow the operating procedure prescribed in this manual.

NOTE:

To accomplish the operation in an efficient manner, additional instructions concerning the operation are given in this section.

G2GI00007-00000

ABBREVIATION CODES

The abbreviation codes that appear in this service manual stand for the following, respectively.

Abbreviation code	Original word	Meaning
A/C, AC	Air Conditioner	Refers to air conditioner.
A/Y, Ay	Assembly	Refers to an assembled component comprising more than two single parts or subassembly parts.
API	American Petroleum Institute	The standards set forth by the American Petroleum Institute (abbreviated as API Classification) have been employed to evaluate and classify properties of various oils. Engine oils for gasoline engines are classified as SD, SE, SF and so on, whereas engine oils for diesel engines are classified as CC, CD and so on.
BDC	Bottom Dead Center	The piston at bottomed position in cylinder.
BTDC	Before Top Dead Center	The piston positioned before most upper position in cylinder.
BVSV	Bimetal Vacuum Switching Valve	Refers to bimetal vacuum switching valve.
C/O	Choke opener	Refers to choke opener.
C/W	Choke warning	Refers to choke warning.
EVAP	Fuel evaporative emission control	Refers to fuel evaporative emission control.
EX	Exhaust (Manifold, Valve)	Refers to exhaust.
F/L	Fusible Link	Refers to fusible link.
GND	Ground	The terminal connected to body ground.
HIC	Hot Idle Compensator	Refers to hot idle compensator.
ISO	International Organization for Standardization	The standards set forth by the international organization for standardization (abbreviation as ISO classification) Standardization have been employed to evaluate and classify properties of various component parts and oils etc.
ITC	Intake air Temperature Compensating valve	Refers to intake air temperature compensating valve.
L.H.D.	Left Hand Drive	Left hand drive vehicles.
L/	Less	Denote that the following part is not attached.
LH	Left Hand	Refers to left side.
LLC	Long Life Coolant	Refers to long life coolant.
M/T, MT	Manual Transmission	Refers to manual transmission
MP	Multipurpose	Means that the following item has multi-purpose
O/S	Oversize	In instance where fitting becomes too loose due to were resulting from use for a long period of time or due to frequent removal/installation operations, if the fitting part having larger dimensions, the other mating part may be put into use again. "Oversized" parts denote those parts having larger dimensions compared with the standard parts.
PCV	Positive Crankcase Ventilation	Refers to positive crankcase ventilation.
PR	Ply Rating	Represents strength of tires. The larger the ply rating number, the stronger the tire st length.
R.H.D	Right-Hand Drive	Right hand drive vehicle.
RH	Right Hand	Refer to right side.
S/A	Subassembly	Refer to a component comprising more than two single parts which are welded, ataked, or studded to each other or form a single component.
SAE	Society of Automotive Engineers	For example, automotive oils are designated as SAE so and so number. These designation numbers have been set forth by the Society of Automotive Engineers in the United State of America (SAE). The larger the SAE number, the higher the oil viscosity. Conversely, the smaller the SAE number, the lower the oil viscosity.
SST	Special Service Tool	Refer to a tool designed for a specific purpose.

Abbreviation code	Original word	Meaning
STD	Standard	When referring to automotive part, "standard" represents those parts which have been installed originally by the manufacturer and which have standard dimensions.
T	Torque	Refer to tightening torque.
TDC	Top Dead Center	Refer to piston at upper position in cylinder.
TP	Throttle Positioner	Refer to throttle positioner.
TWC	Three-Way Catalyst	Refer to three-way catalyst.
SD	Spark Delay	Refer to spark delay.
Spec.	Specifications	Refer to specification.
U/S	Under Size	In the same manner as with the "oversized" part (e.g. bush and bearing) is replaced with a part having smaller bore dimensions, the other mating part may be put into use again. "Under sized parts denote those part having smaller dimensions compared with standard parts.
VSV	Vacuum Switching Valve	Refers to vacuum switching valve.
VTV	Vacuum Transmitting Valve	Refers to vacuum transmitting valve.
W/	With	Denotes that the following part is attached.
W/O	With Out	Denotes that the following part is not attached.
ETR	Electronic Tuning Radio	Radio which on corporates variable capacitance, etc. which varies the value according to an applied voltage or current

The abbreviation codes that appear in the figure stand for the following, respectively.

B	Bolt	S	Screw
N	Nut	W	Washer

TOWING INFORMATION

If towing is necessary, we recommend you have it performed by an authorized Daihatsu dealer or a commercial tow truck service.

If one or some wheels, axles, brake system or power train is damaged, use a towing dolly.

G2GI0009-00000

1. Towing with rear wheels on the ground

CAUTION:

- This towing method must be limited to only cases where there is no trouble in the power train, rear axle, brake system and so forth.
- Be sure to release the parking brake fully.

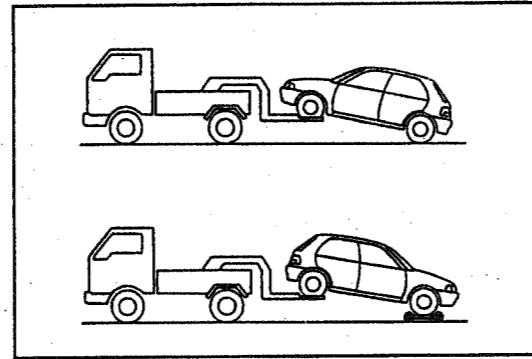

G2GI0010-99999

2. Towing with rear wheels off the ground

CAUTION:

- When there is a trouble in the power train, rear axle, brake system and so forth, be sure to tow the vehicle in such a way that all wheels are not rotating.

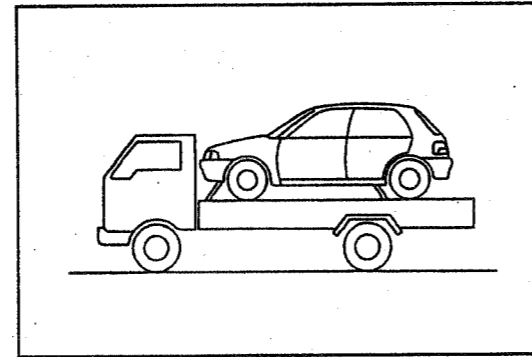

G2GI0011-99999

JACKING POINTS & SUPPORTING POINT OF SAFETY STANDS

CAUTION:

- Be sure to support the vehicle at flat surface of the rocker panel.
- Do not support the vehicle at the edge part of the rocker panel Hange.

• **Jacking point**

Front side Engine lower member
 Rear side Rear floor cross member

○ Supporting point of garage jack
 □ Supporting point of safety stand

Front: Engine lower member Rear: Rear floor cross member

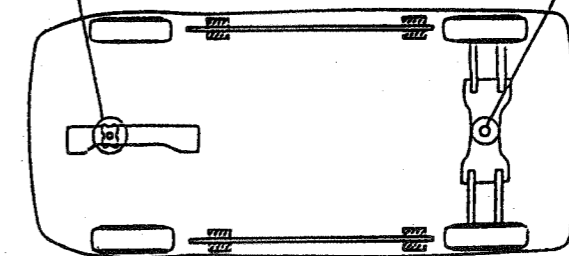

• **Supporting points of safety stands**

Four supporting points are located at the right and left sides. (The supporting point have been strengthened by spot-welding reinforcements. Never support the vehicle at points other than the specified points.)

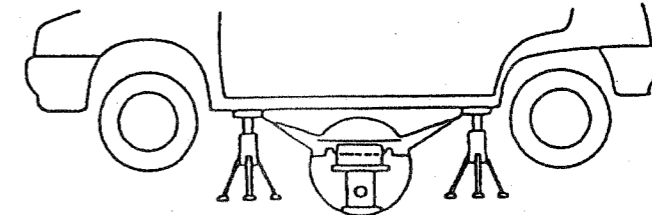

• **Supporting point of two-post lift**

Align the supporting pads of a two post lift with the supporting points of safety stands, as indicated in the figure above.

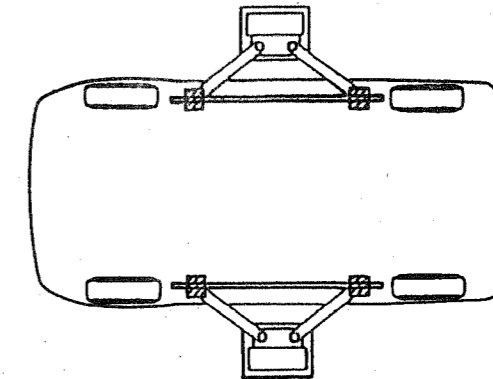

• **Supporting point of plate supporting type lift**

Vehicle should be placed at the center of the supporting plates of the lift. When lift up the vehicle be sure to support the front section of the vehicle.

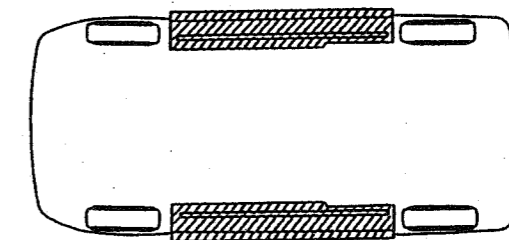

G2GI0012-99999

GENERAL SERVICE INSTRUCTION

1. Use fender covers, seat covers and floor sheets so that the vehicle may not get dirty or be scratched.
2. Jacking up
 - (1) When only the front section or rear section of the vehicle is jacked up, be sure to place chocks at the wheels so as to insure safe operations.
 - (2) When the vehicle has been jacked up, be sure to support the vehicle at the specified section using the safety stands. (See page GI-9)
3. Handling instructions related to battery.
 - (1) Before you start performing the electrical works, make certain to disconnect the battery ground cable terminal from the negative (-) terminal of the battery.

NOTE:

 - After reconnect the battery ground cable terminal to the negative terminal of the battery, be sure to reset the watch or radio, if vehicle equipped with such equipments.
 - (2) When it becomes necessary to disconnect the battery power supply for the purpose of carrying out checks or repairs, always disconnect the negative (-) terminal of the battery ground cable from negative terminal of the battery first.
 - (3) To avoid damaging battery plates, after the terminal nut has been loosened, pull out the battery ground cable terminal straight upward, rather than turning or prying the terminal.

NOTE:

 - Be sure to employ the battery terminal puller (commercially available) to remove battery ground cable terminal from the negative terminal of the battery, if encountered any difficulty.
 - (4) Clean the battery terminal posts or battery ground terminals, using a cloth. Never use a file or other adhesive agents.
 - (5) When connecting the battery ground cable terminal to the battery, first the battery ground cable terminal should be fitted onto the battery post with the attaching nut in a loose state. Then, tighten the nut. Never tap the terminal onto the battery post, using the hammer or spanner wrench or the like.
 - (6) As for the cover at the positive (+) terminal side, be sure to install it at the correct position.
4. Repairing of fuel system
 - (1) When connect/disconnect the fuel line.
 - ① Tighten each connecting section to the specified torque.
 - ② Attach the new specified clips to each connecting section.
 - ③ Be certain to place the suitable container or close, etc. under the connected section of fuel line before disconnect the fuel line.
 - ④ Before the fuel line is disconnected, be sure to release the inner pressure of the fuel tank by detaching the fuel filler cap.
 - (2) Do not work near open frames.
5. For increased work efficiency and improved accuracy, be sure to utilize the SSTs (Special Service Tools) effectively.

6. Removal and disassembly
 - (1) When disassembling complicated components, put stamped marks or mating marks on the those sections where such marks do not affect their functions so that the assembling operation may be performed easily.
 - (2) Each time a part removed, check the part for the assembled condition, deformation, breakage, roughness and scratches.
 - (3) Arrange the disassembled parts in the disassembling order. In addition, separate and arrange those parts tube replaced and those parts tube reused.
 - (4) Thoroughly clean and wash those parts to be reused.
 - (5) Inspection and measurement of part
Perform thorough inspection and measurement on those parts to be reused, as required.
7. Installation and assembly
 - (1) Assemble those satisfactory parts, following the proper procedure and specified standard. (adjusting values and tightening torque, etc.)
 - (2) Ensure that seal packings and grease are applied to those sections where such application is needed.
 - (3) Be sure to use new packings, gaskets, cutter pins and so forth.
 - (4) Ensure that the specified bolts and nuts only be used. Moreover, where specified, make sure to employ a torque wrench to tighten bolts and nuts to the specified torque.
Make sure to use only genuine parts for every replacement.
8. Adjustment and operation check
Adjustment the reassembled or replaced components to the servicing specifications, using gauges and testers, as required.
9. Handling of hoses, etc.
 - (1) Connect fuel hoses and ware hoses, etc. securely so that they exhibit no leakage.
 - (2) When disconnecting fuel hoses, make sure that on fuel is splashed around the hoses. (Special care must be exercised as to the engine mount rubber, etc., for there is a possibility that the rubber is deteriorated by the petrol-based liquid.)
10. Observe the following precaution to avoid damage to the parts.
 - (1) When puking out vacuum hose, be sure to hold the hose end, not the middle part of hoses.
 - (2) When disconnecting connectors, be sure to hold the connector itself, not the wire portion.
 - (3) Be very careful not to drop electrical components, such as sensors or relays, to the floor. If they are dropped, they must be replaced with new one. Never reuse them.
 - (4) When steam cleaning the engine, take precautionary measures so that no water is applied to the air filter, carburetor, distributor, ignition coil and so forth.
 - (5) Never use an impact wrench to remove or install thermo switches or thermo sensors.
 - (6) When checking continuity at the wire connector, insert the tester probe carefully to prevent terminal from bending.
 - (7) When using a vacuum gauge, never force the hose onto a connector that is too large. Use a step-down adapter instead. Once the hose has been stretched, it may leak.

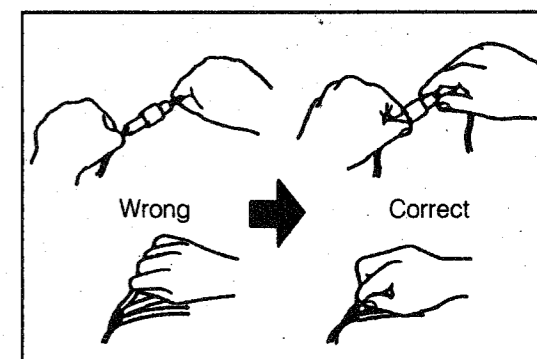

G2GI00014-89999

G2GI00013-00000

11. Tag hoses before disconnecting them:
- (1) When disconnecting vacuum hoses, use tags to identify how they should be reconnected.
 - (2) After completing a job, double check that the vacuum hoses are properly connected. A label under the hood shows the proper layout.

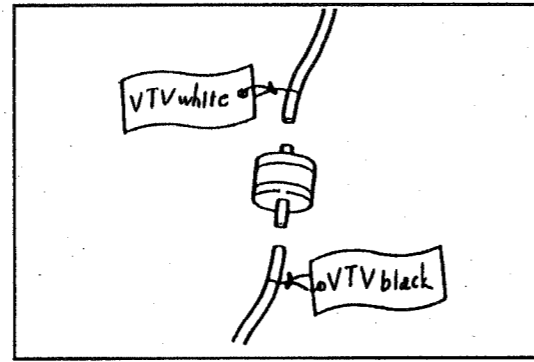

G2GI00015-99999

12. The dimensions and specified values that appear in this manual are those values at 20°C (68°F), unless otherwise specified.

13. As for the values other those indicated in "si" unit, such as ft, inch and lb they are the converted values. Therefore, there are cases where the converted values have been rounded up or down according to their use at the time of conversion.

14. Connect the resistive cords as follows:
- (1) Connect the resistive cords to the distributor cap in such a way that the resistive cords may assume an angle as indicated in the right figure.
 - (2) Care must be exercised to ensure that the resistive cords may not interfere with any periphery parts.

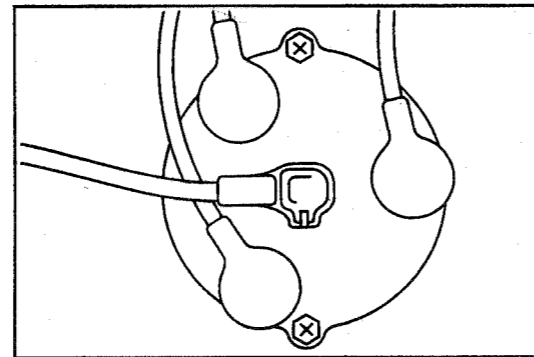

G2GI00016-99999

- (3) Connect the resistive cords to the air cleaner case in such way that the resistive codes may assume an angle as indicated in the right figure.

NOTE:

- Care must be exercised to ensure that the plug side connector of the resistive cord grommet part should be munched with reassessed part of air cleaner case.

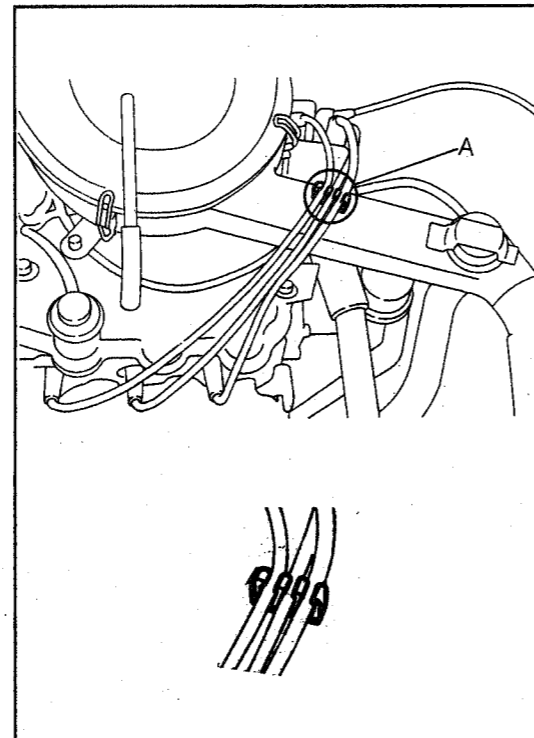

G2GI00017-99999

- (4) When connect or disconnect the resistive cord, be sure to hold the rubber boot section of the resistive cord, not to hold the cord sections.

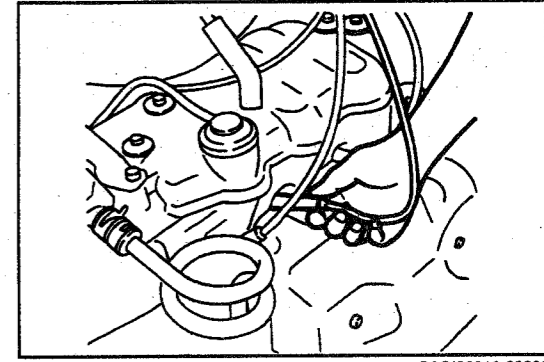

G2GI00018-99999

15. Handling of clamp, etc.
As for the removed hose bands and clamps, etc., be certain to reassemble them securely in the respective original position.

G2GI00019-00000

HANDLING INSTRUCTIONS ON CATALYTIC CONVERTER-EQUIPPED VEHICLES

WARNING:

When a grate amount of unburnt gas is admitted into the catalytic converter, overheating is prone to occur, resulting in a fire hazard.

To avoid such trouble in advance, be certain to observe the following precautions. Also, be sure to explain such precautions to your customers.

1. Use only unleaded gasoline to catalytic converter-equipped vehicles.
2. Avoid idling the engine for a prolonged length of time.
Do not run the engine continuously at idle speed for more than 20 minutes.
- WARNING:**
Immediately check and repair the vehicle, in case if fast idle speed or idle speed are unstable or system having malfunction. Failure to observe this warning may resulting in a fire hazard.
3. Be sure to observe following points when performing the spark jump tests.
 - (1) The spark jump test must be limited to cases where such test is absolutely necessary. Also, be sure to finish the test in the shortest possible time.
 - (2) Never race the engine during the test.
 - (3) Be sure to shut off the fuel supply when preforming the spark jump test in advance.
4. Do not run the engine when the fuel tank becomes nearly empty.
Failure to observe this caution will causes misfiring. Also, it will apply excessive load to the catalytic converter, even leading to catalyst damage.
5. Do not dispose the waste catalyst along with parts contaminated with gasoline or oil.

G2GI00020-00000

MODEL VARIATION

Item					General specification		Australian specification	European specification	
Type	Door	Engine type	Grade	Trans- mission	RHD	LHD	RHD	RHD	LHD
Sedan	3 door	CB	TS	5M/T	G202RS-FMDS	G202LS-FMDS	G202RS-FMDSQ	—	*G202LS-FMDSW
	5 door	CB	CS	5M/T	G202RS-GMDS	G202LS-GMDS	G202RS-GMDSQ	—	*G202LS-GMDSW
Van	3 door	CB	—	5M/T	G202RV-YMDS	G202LV-YMDS	—	—	—

* Only for East European spec.

G2GI00021-00000

Explanation of vehicle model code

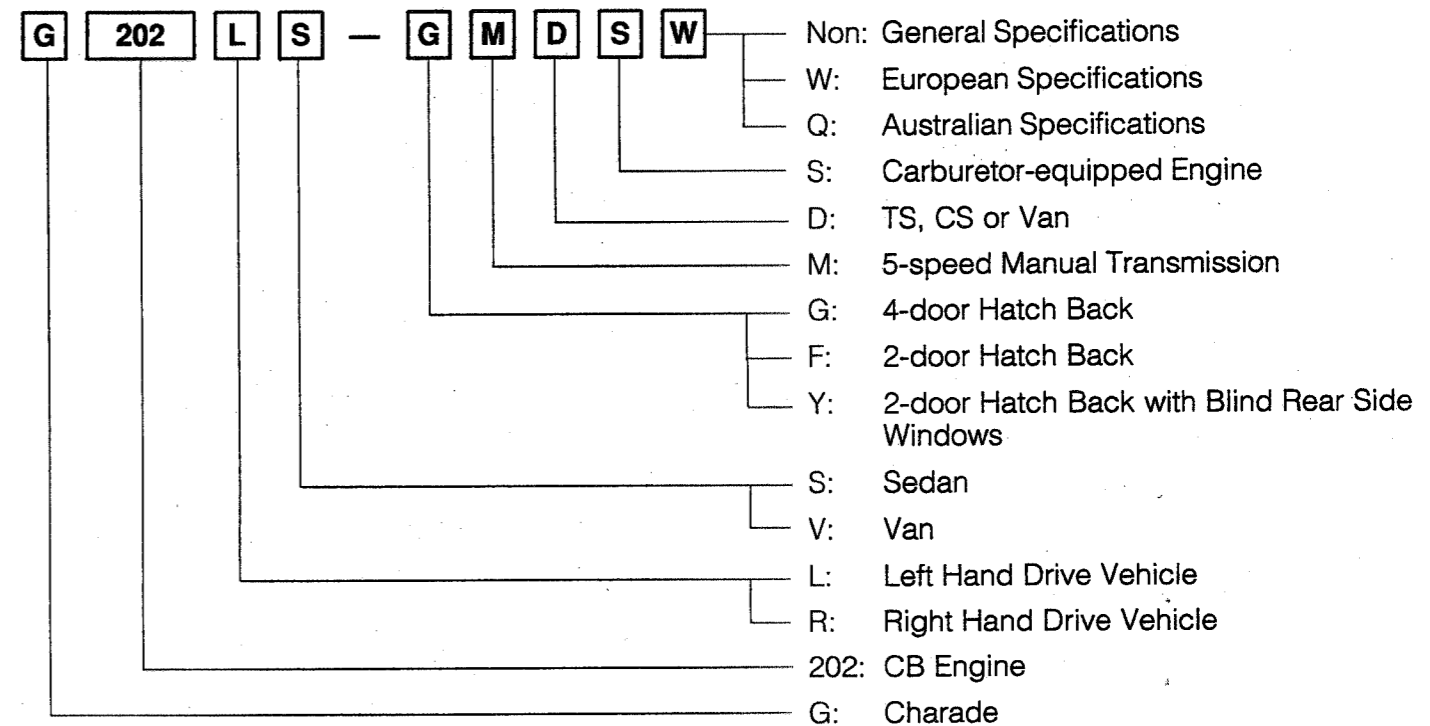

G2GI00022-00000

CHASSIS SERIAL NUMBER STAMPED POSITION

The chassis number is stamped on the cowl panel at the right side in the engine compartment.

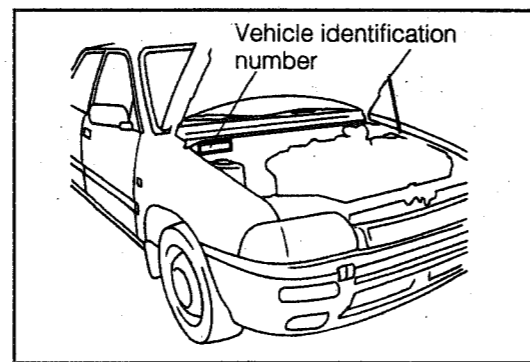

G2GI00023-99999

MANUFACTURE'S PLATE POSITION

The manufacturer's plate is attached on the cowl panel.

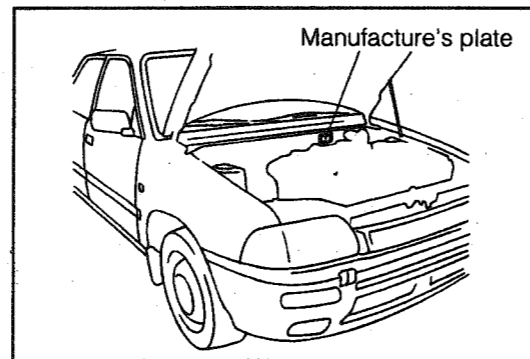

G2GI00024-99999

CONTENTS OF MANUFACTURER'S PLATE

(1) General, Australian, Norwegian and Finnish Specifications

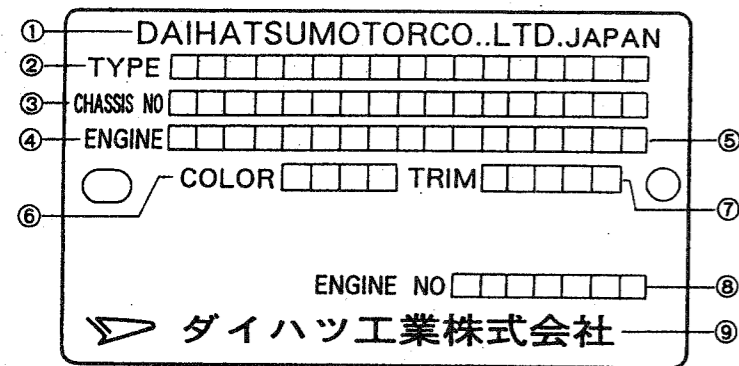

- ① Manufacturer's name, Country
- ② Vehicle model
- ③ Chassis No.
- ④ Engine type
- ⑤ Engine displacement
- ⑥ Body colors
- ⑦ Trim code
- ⑧ Engine number
- ⑨ Manufacturer's name in Japanese
- ⑩ Gross vehicle weight
- ⑪ Gross combination weight
- ⑫ Maximum permissible front axle weight
- ⑬ Maximum permissible rear axle weight
- ⑭ Production month-year (Only for AUS spec.)

(2) European Specification (except for Norway and Finland)

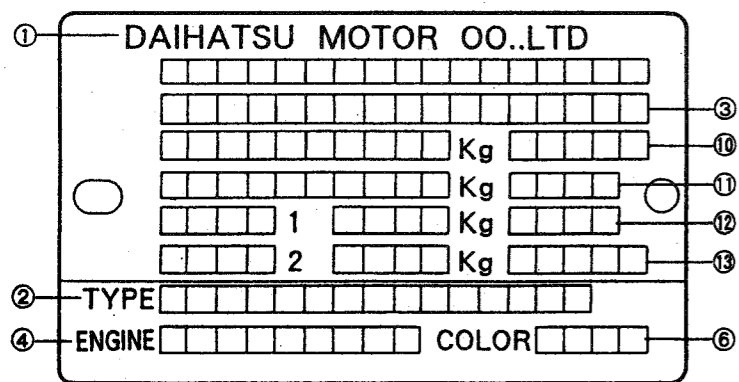

G2GI00025-99999

ENGINE NUMBER AND ENGINE TYPE STAMPED POSITIONS

- The engine number is stamped on the cylinder head.
- The engine type is indicated by embossed letters on the cylinder block.
- For Australian specifications
The engine number is stamped on the cylinder block.
The engine type is indicated by embossed letters on the cylinder block.

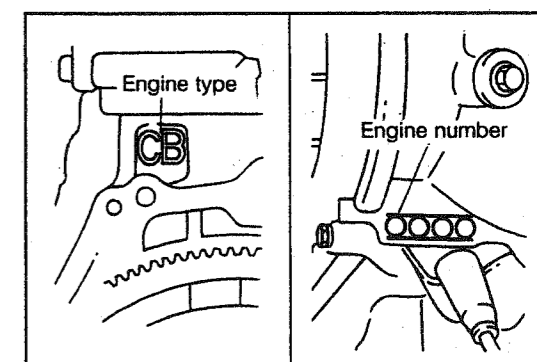

G2GI00026-99999

BODY COLOR INFORMATION

Color name	Code
White	W09
Greenish gray mica	*S14
Pure red	*R19
Dark blue mica	*B23
Light turquoise metallic	*G16
Black metallic	6A5

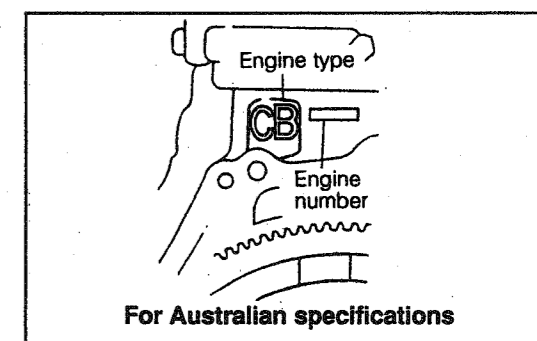

For Australian specifications

G2GI00027-99999

The asterisk mark "*" indicates the employment of new color.

COLOR CODE IN THE WORLD

Color name	Color code				
	DAIHATSU	DUPONT	ICI	SPIES HECKER	STANDOX
White	W09	K9344	XM48	16461	W09
Greenish gray mica	S14	H9925	5GK9B	60439	S14
Pure red	R19	H9924	5GL1	30423	R19
Dark blue mica	B23	H9853	2RM2B	50330	B23
Light turquoise metallic	G16	H9923	5GK8B	60440	G16
Black metallic	6A5	L7902	A403B or B929B	96326	6A5

G2GI00028-00000

TRIM CODE



- Trim color code
- S Grey
- Serial code
- A code that has been set in alphabetical order.
- Seat main material
- F.Y: Fabric
- L: Vinyl chloride leather

G2GI00029-00000