DAIHATSU

G202

CB-Engine

IGNITION SYSTEM

OUTLINE OF IGNITION SYSTEM	IG- 2
IN-VEHICLE INSPECTION	IG- 3
DISTRIBUTOR	IG-13
SERVICE SPECIFICATIONS	IG-22
TIGHTENING TORQUE	IG-22
SSTs	IG-22

NOTE:

The contents described in the service manual have been explained in the EM section. Please refer to the EM section, as required.

OUTLINE OF IGNITION SYSTEM

On G202 series vehicles, the ignition system is fully-transistorized type. The full transistorized ignition method incorporates the signal generator in the distributor, instead of the contact points in the conventional ignition method. This signal generator consists of a signal rotor, a magnet and a pickup coil. Ignition signals are generated electrically through the rotation of the signal rotor.

Since the full transistorized ignition method incorporates no contact points, this method is free from all problems attributable to contact points. Thus, there is no need for maintenance related to contact points.

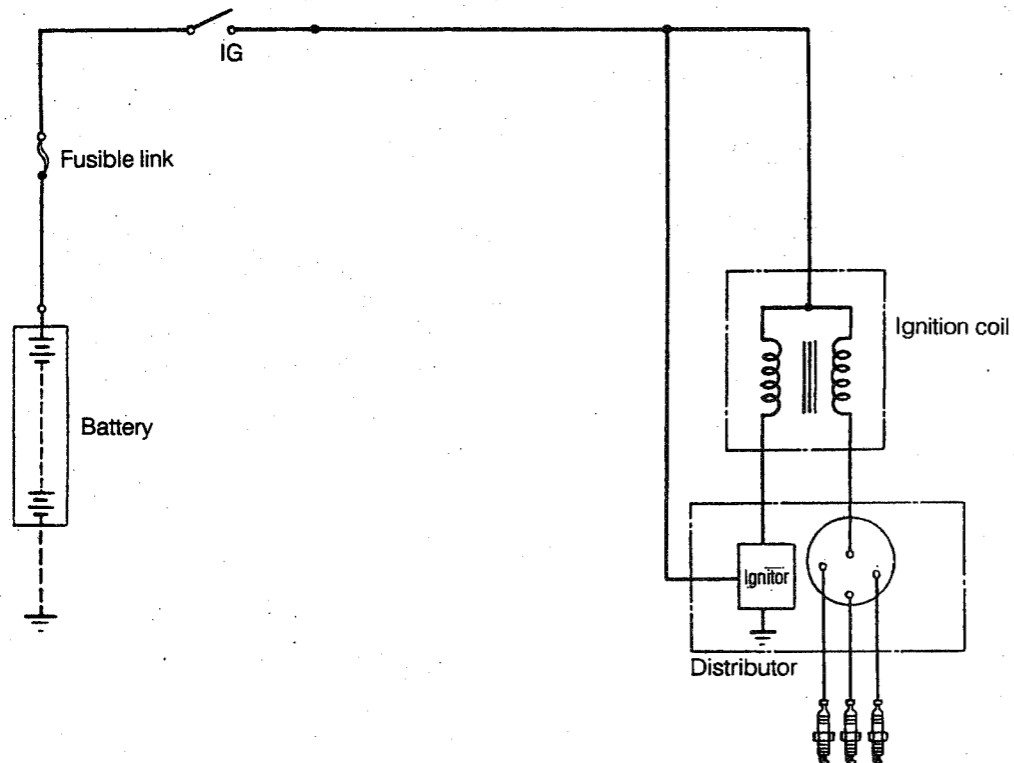

IN-VEHICLE INSPECTION

SPARK TEST

(Check to see if spark occurs)

1. Turn OFF the ignition key switch.

2. Connect a timing light to the resistive cord between the distributor and the ignition coil.

NOTE:

- Be very careful not to damage the wire.

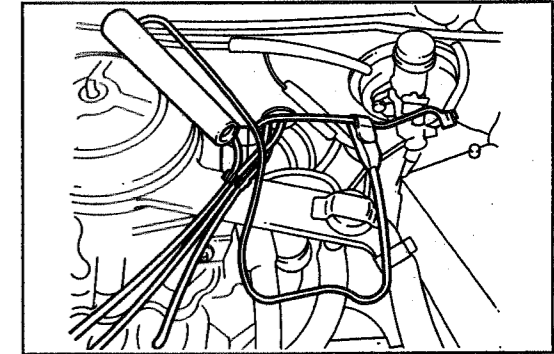

3. Ensure that the timing light flashes while the engine is being cranked by the starter motor. If the timing light flashes, check the resistive cord and spark plug. If the timing light will not flash, perform the check according to the chart given below.

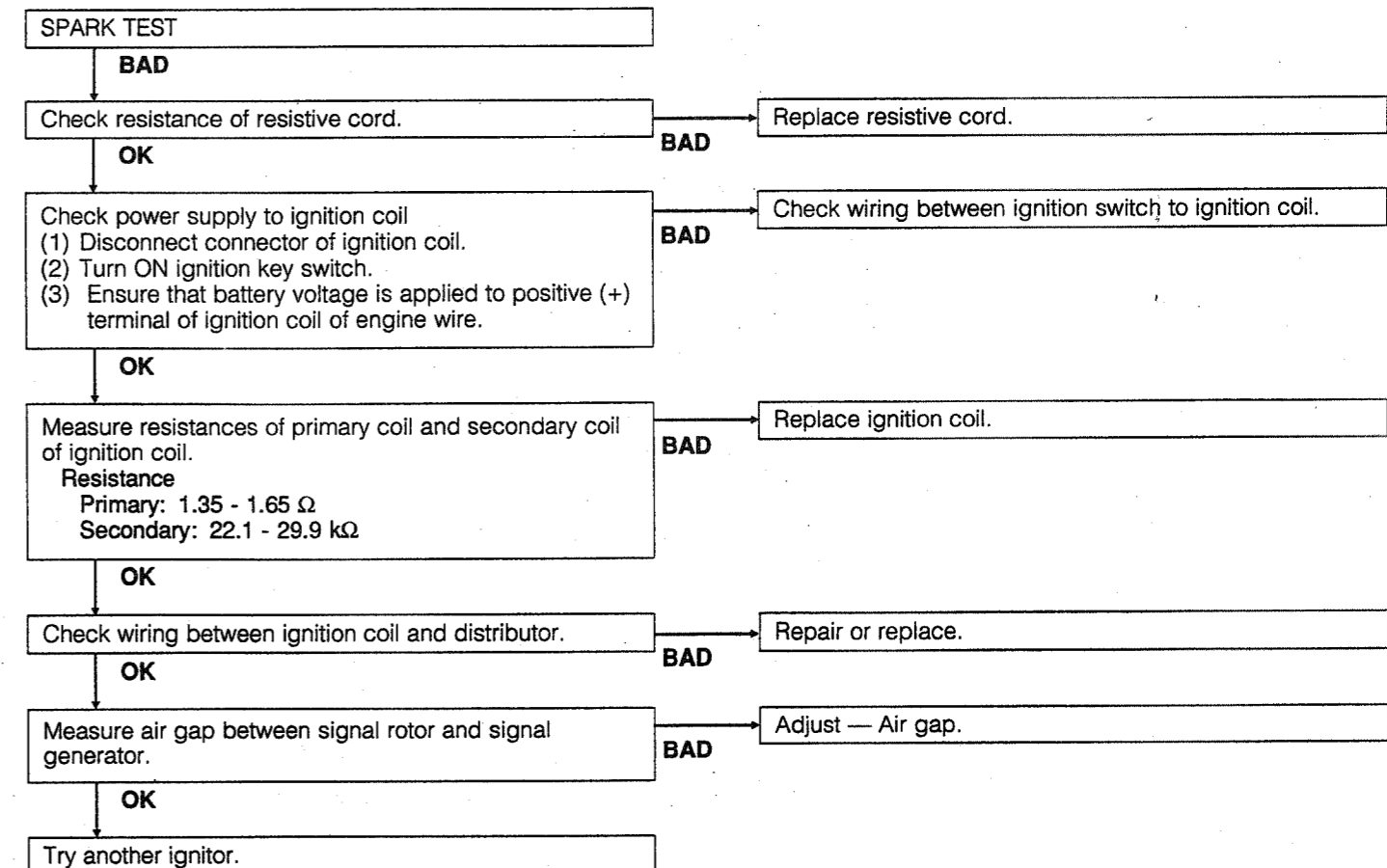

INSPECTION AND ADJUSTMENT OF IGNITION TIMING

NOTE:

- The ignition timing inspection or adjustment is performed normally when the engine is in a Hot condition. "Hot engine condition" denotes a condition in which the cooling water temperature is 75 - 85°C (167 - 185°F) and the engine oil temperature is above 65°C (149°F).

- Start the engine.
- Warm up the engine.
- Stop the engine.
- Connection of tachometer.
 - Disconnect the connector of the ignition coil.
 - Connect the following SST between ignition coil and vehicle side of ignition coil connector. (If your tachometer is clamp on type this operation is unnecessary.)

SST: 09991-87604-000

- Connect the tachometer to the engine.

CAUTION:

- Never allow the tachometer terminal to touch ground. It could result in damage of the ignition system.
- As some tachometers are not compatible with this ignition system, it is recommended to confirm the compatibility with your unit before its use.

REFERENCE:

Engine tachometer

- In the case of a tachometer which picks up signals from the primary circuit and is not provided with a 3-cylinder range, take a reading of the revolution speed on a 6-cylinder range. Then, multiply this reading by 2. This value is the actual revolution speed for the 3-cylinder engine.

- Connect a timing light to the resistive cord of the No. 1 cylinder (at the timing belt side.).
- Disconnect the vacuum hose at the sub-side of the vacuum advancer of distributor.
- Plug the disconnected vacuum hose, using the following SST.

SST: 09258-00030-000

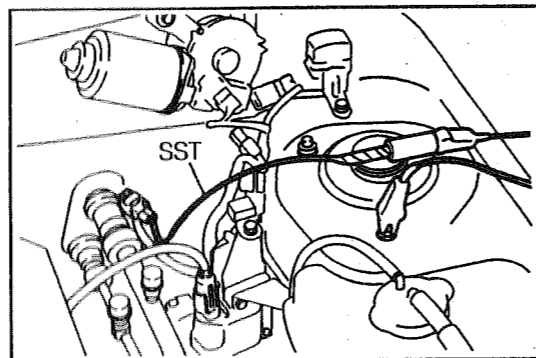

G21G00006-99999

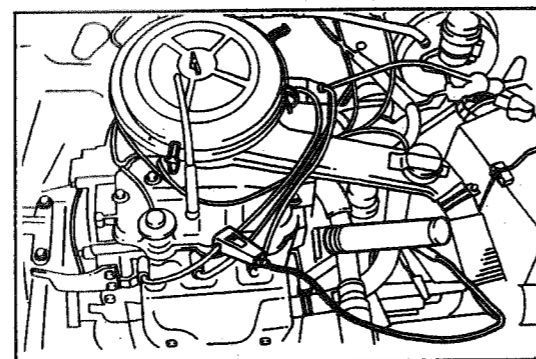

G21G00008-99999

- Start the engine.
- Ensure that the engine revolution speed is below 1000 rpm and stable. If the engine revolution exceeds 1000 rpm or it is unstable, adjust the engine revolution speed to the idle speed. (See page MA-36)

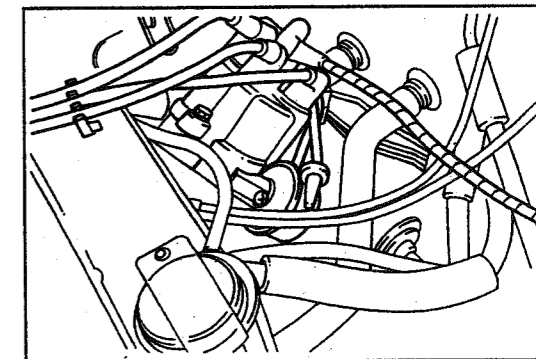

G21G00009-99999

- Check to see if the ignition timing mark of the fly wheel is aligned with the indicator of the engine rear end plate, using the timing light. Adjust the ignition timing by turning the distributor, if the ignition timing mark is not aligned with indicator.
- Adjustment of ignition timing
 - Loosen the distributor attaching bolts.
 - Adjust the distributor installation angle by turning the distributor, until the ignition timing mark of the flywheel is aligned with the indicator of the engine rear end plate.

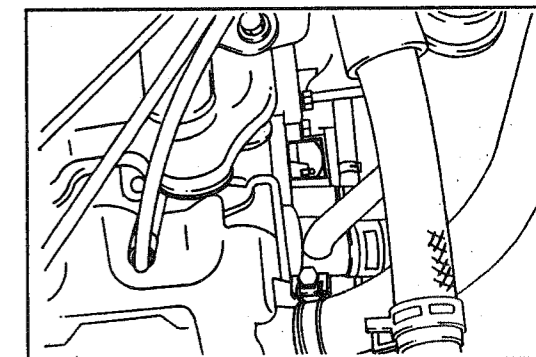

G21G00010-99999

REFERENCE:

- If the distributor is turned clockwise, the timing will be advanced. Conversely, if the distributor is turned counterclockwise, the ignition timing will be retarded.

- Tighten the distributor attaching bolts to the specified torque, making sure that the ignition timing is not disturbed.

Tightening Torque: 14.7 - 21.6 N·m
(1.5 - 2.2 kgf-m, 10.8 - 15.9 ft-lb)

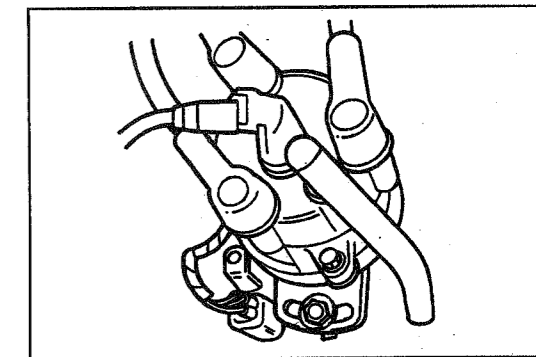

G21G00011-99999

- Stop the engine.
- Remove the tachometer.
- Remove the SST from ignition coil connectors.
- Reconnect the ignition coil connector.
- Remove the SST from vacuum hose end.
- Connect the vacuum hose at the sub-side of the vacuum advancer of distributor.
- Adjust the idle speed.

INSPECTION OF RESISTIVE CORDS

- Carefully remove the resistive cords from the spark plugs and ignition coil by holding their rubber boots.

CAUTION:

- Do not hold the cord portion or bend the cord. Otherwise, the conductor inside the cord may be damaged.

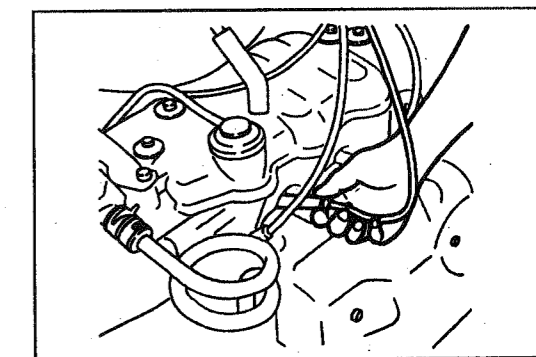

G21G00012-99999

2. Disconnect the resistive cords from the clamp.
3. Remove the distributor cap.
4. Inspection of resistance of resistive cord and distributor cap terminal.

Maximum Resistance: 15 kΩ

If the resistance exceeds the maximum limit, check the distributor cap terminals.
Replace the resistive cord and/or distributor cap, as required.

5. Install the distributor cap with a new distributor cap gasket interposed.

NOTE:

- If the distributor gasket is damaged, replace it with a new one.

6. Connect the resistive cords to the spark plug.

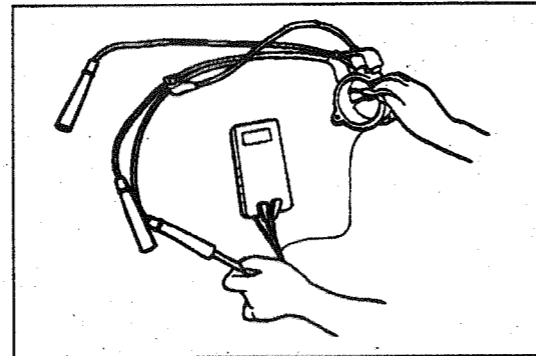

G2IG00013-99999

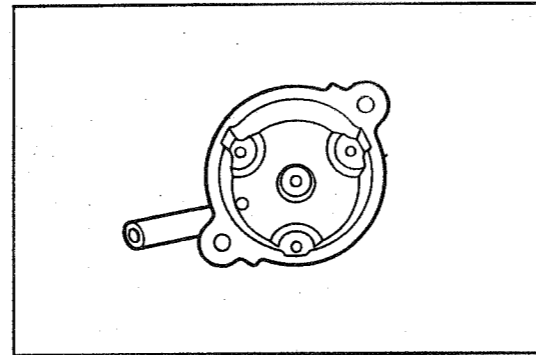

G2IG00014-99999

G2IG00015-00000

INSPECTION OF SPARK PLUGS

1. Carefully remove the resistive cords from the spark plugs by holding their rubber boots.
2. Inspection of electrode

- (1) When a megger (Insulation resistance meter) is used:
Measure the insulation resistance of the spark plug.
Minimum Insulation Resistance: 15 MΩ

If the measured insulation resistance is less than 15 MΩ, proceed to the step 3.

- (2) When a megger is not available:

- ① Start the engine. Warm up the engine completely.
- ② Race the engine at 4000 rpm for five seconds.
- ③ Proceed to step 3.

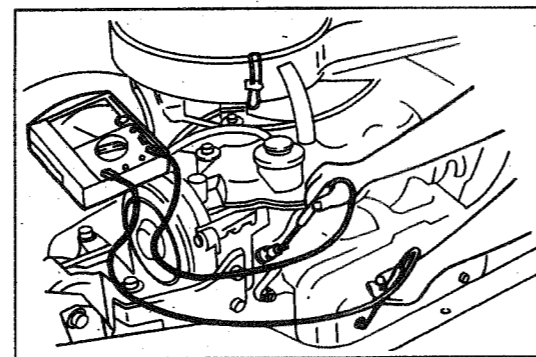

G2IG00016-99999

G2IG00017-00000

3. Remove the spark plug.

CAUTION:

- When the operation the step 2 ② is performed, care must be exercised to avoid getting scalded, for the spark plugs may be still very hot.

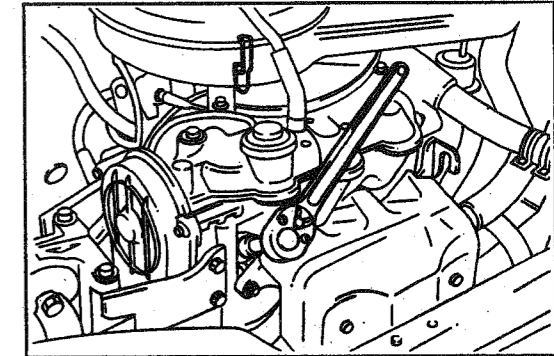

G2IG00018-99999

4. Visual inspection of spark plug

Visually inspect the spark plug for electrode wear, thread or insulator damage.

Replace the spark plug if it exhibits damage.

If the electrode is dry: Satisfactory, proceed to the step 5 → 6.

If the electrode is wet: Proceed to the step 6 → 5.

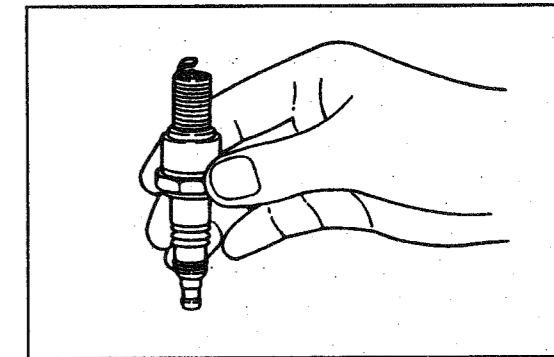

G2IG00019-99999

5. Inspection of electrode gap

Measure the electrode gap, using the plug gap gauge.

Electrode Gap:

NIPPONDENSO: 0.7 - 0.8 mm
(0.028 - 0.031 inch)

NGK: 0.8 - 0.9 mm (0.031 - 0.035 inch)

If the electrode gap of a used spark plug is not within the specification, replace the spark plug with new one.

If the electrode gap of a new spark plug is not within the specification, adjust the gap by bending the base of the ground electrode, being careful not to touch the tip.

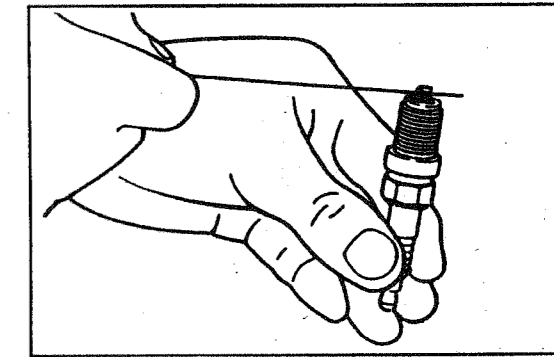

G2IG00020-99999

Recommended Spark Plug:

	NIPPONDENSO	NGK
For European Specification	W16EXR-U	BPR5EY
Except for European Specification	W16EX-U	BP5EY

G2IG00021-00000

NOTE:

- All four plugs should be the same heat range and be ones manufactured by the same manufacturer.

6. Cleaning of spark plug

If the electrode has traces of wet carbon, dry the electrode and clean it with a spark plug cleaner.

Air Pressure: Not to exceed 588 kPa (6 kgf/cm²)

Duration: Less than 20 seconds

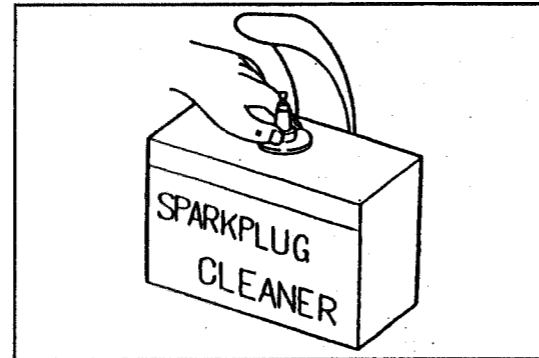

G2IG00022-99999

NOTE:

- If there are traces of oil, remove it with gasoline before the spark plug is cleaned by the spark plug cleaner.

7. Inspection of spark plug insulation resistance

More Than 20 MΩ

If the insulation resistance is less than the specified value, replace the spark plug.

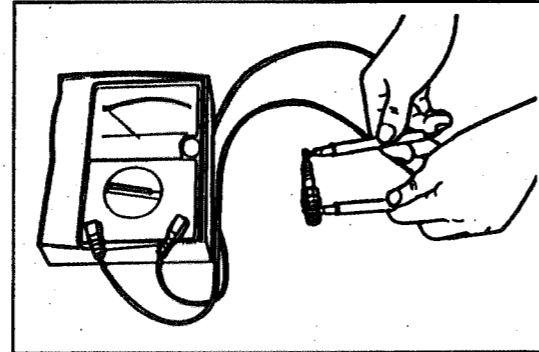

G2IG00023-99999

8. Installation of spark plug

Install the spark plugs. Tighten them to the specified torque.

Tightening Torque: 14.7 - 21.6 N·m

(1.5 - 2.2 kgf-m, 10.8 - 15.9 ft-lb)

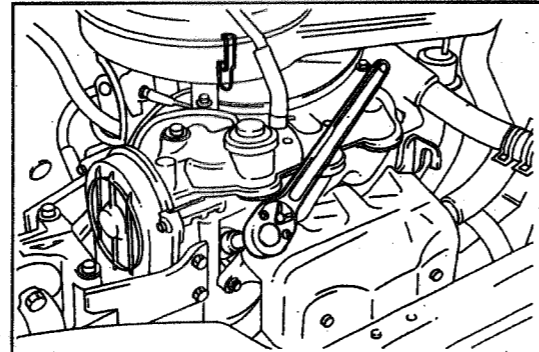

G2IG00024-99999

9. Connect the resistive cord to the spark plug.

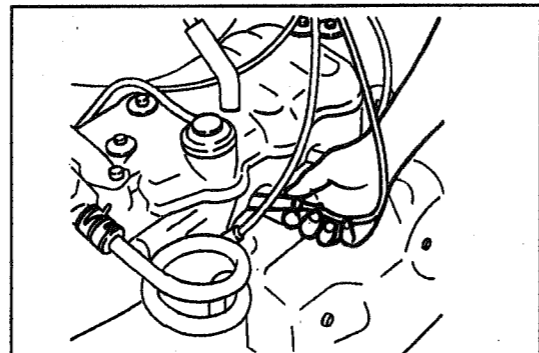

G2IG00025-99999

INSPECTION OF IGNITION COIL

1. Disconnect the resistive cord from the ignition coil.

NOTE:

- Do not hold the cord during the disconnection. Be sure to disconnect the cord by holding its rubber boot.

2. Disconnect the cowl wire connector from the ignition coil.

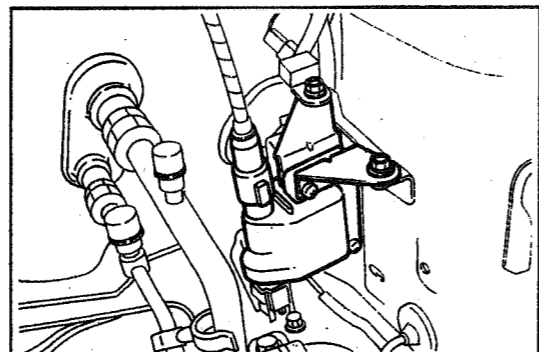

G2IG00026-99999

3. Check of primary coil resistance

Measure the resistance of the primary coil across the terminals of the ignition coil connector.

Primary Coil Resistance (at 20°C): 1.35 - 1.65 Ω

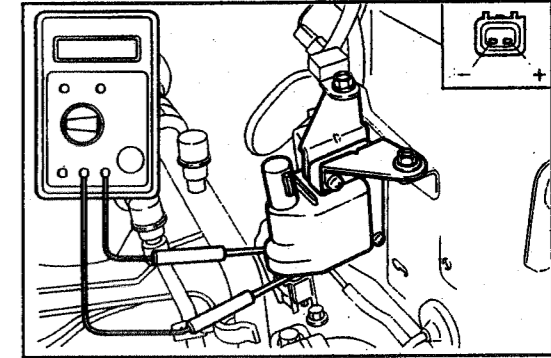

G2IG00027-99999

4. If the measured resistance fails to conform to the specification, replace the ignition coil.

5. Check of secondary coil resistance

Measure the resistance of the secondary coil across the positive (+) terminal of the ignition coil and the resistive cord connecting terminal.

Secondary Coil Resistance (at 20°C): 22.1 - 29.9 kΩ

If the measured resistance fails to conform to the specification, replace the ignition coil.

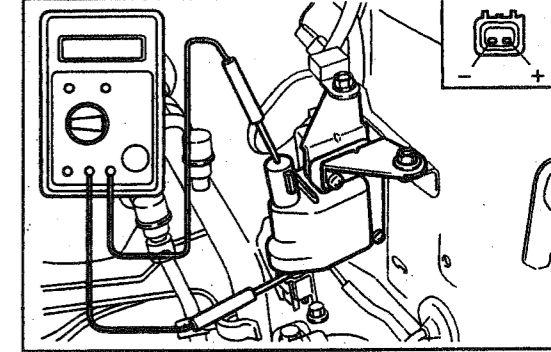

G2IG00028-99999

6. Check of insulation resistance

Ensure that no continuity exists between the positive and negative terminals of the ignition coil and the body ground. If continuity exists, replace the ignition coil.

Insulation Resistance: More than 1000 MΩ (Infinity)

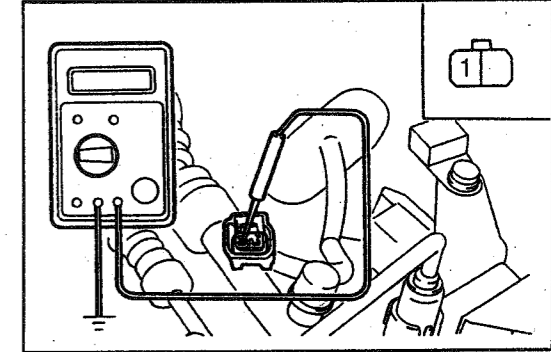

G2IG00029-99999

7. Connect the cowl wire connector to the ignition coil.

8. Connect the resistive cord to the ignition coil.

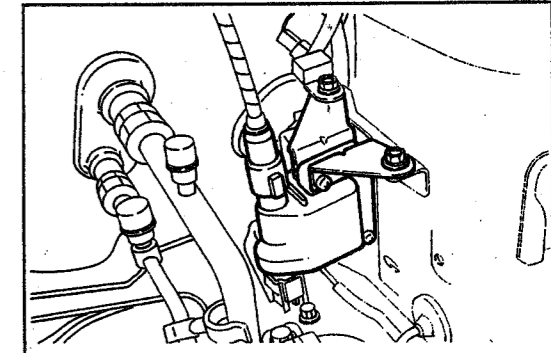

G2IG00030-99999

INSPECTION OF DISTRIBUTOR

Check and adjustment of air gap

1. Remove the resistive cord from the distributor cap.

CAUTION:

- Do not hold the cord portion or bend the cord. Otherwise, the conductor inside the cord may be damaged.

2. Remove the distributor cap.

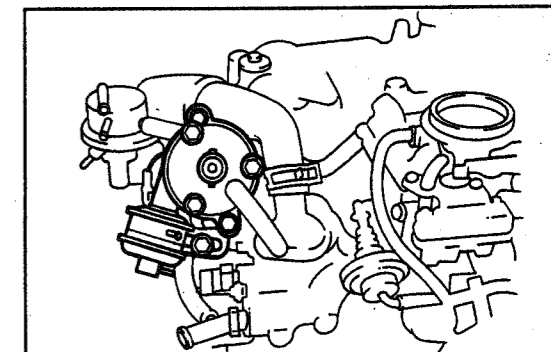

G2IG00031-99999

3. Check of vacuum advancer

- (1) Disconnect the vacuum hoses from the vacuum advancer.
- (2) Apply a negative pressure of more than 20 kPa (150 mmHg). Ensure that vacuum advancer operates. Repair or replace the vacuum advancer, as required, if it will not operate.
- (3) Connect the disconnected vacuum hoses to the vacuum advancer.

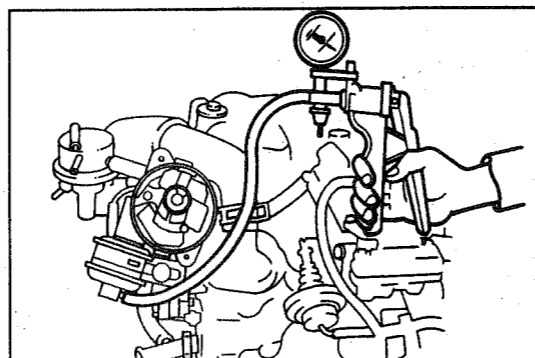

G2IG00032-99999

4. Check of governor advancer

- (1) Turn the rotor counterclockwise and release it. Ensure that the rotor returns clockwise rapidly. Repair or replace the governor advancer, as required, if it will not return to the original position.
- (2) Check the rotor for excessive play. Repair or replace the governor advancer, if it plays excessively.

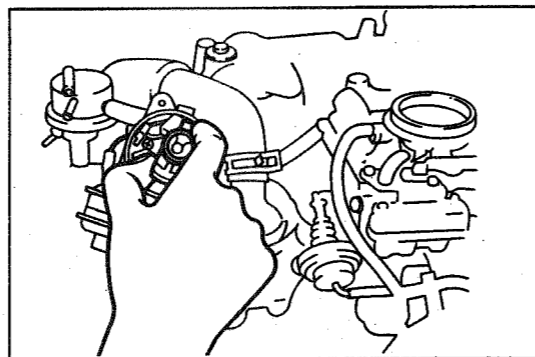

G2IG00033-99999

5. Pull out the rotor.

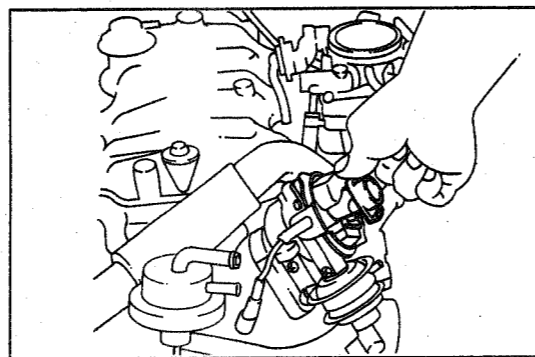

G2IG00034-99999

6. Turn the crankshaft until the signal rotor faces toward the signal generator.

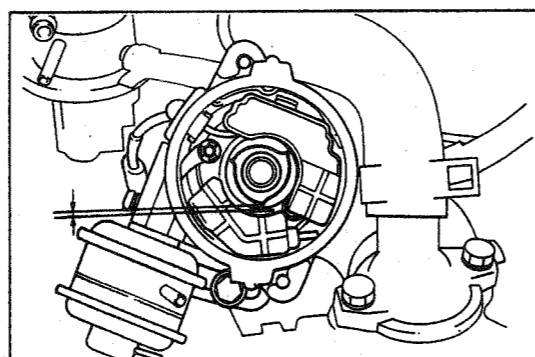

G2IG00035-99999

7. At all four points, check to see if the air gap between the signal generator and the signal rotor conforms to the specified value.

Specified Air Gap: 0.2 - 0.4 mm

If the air gap fails to conform to the specified value, adjust the air gap.

G2IG00036-00000

8. Remove the distributor gasket. Loosen the attaching screws of the ignitor. Then, pull out the ignitor from the distributor housing, making sure that no damage is made to the wire.

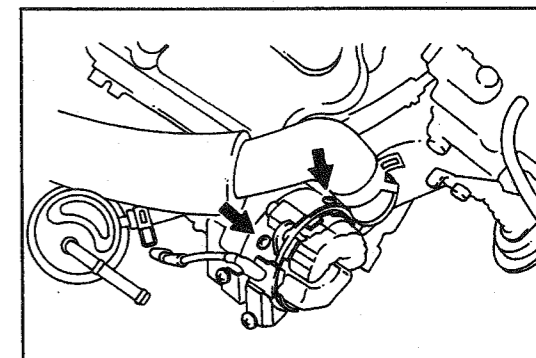

G2IG00037-99999

9. Adjustment of air gap.

- (1) Loosen the attaching screws of the signal generator.
- (2) Adjust the air gap between the signal generator and the signal rotor to the specified value.
- (3) Tighten the attaching screws of the signal generator.

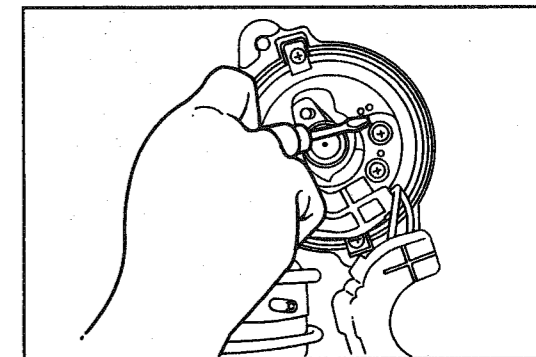

G2IG00038-99999

(4) Check the air gap.
Specified Value: 0.2 - 0.4 mm

If the air gap fails to conform to the specified value, adjust the air gap again.

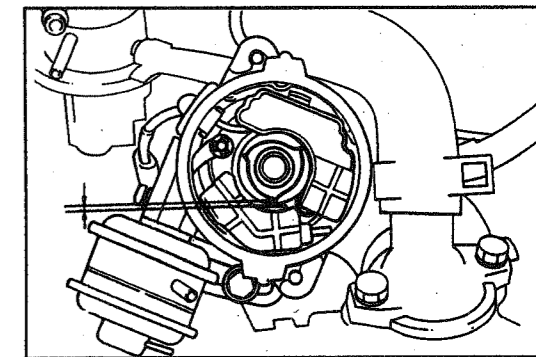

G2IG00039-99999

10. Installation of ignitor

- (1) Install the ignitor in such a position that two lead wires (red & white) are twisted 360° in the clockwise direction as viewed from the ignitor. Hold the lead wires using a clamp provided on the inner side of the housing.
- (2) Care should be exercised to keep ignitor's mounting surface clean.

NOTE:

- It should be noted that if any foreign object is present between the ignitor and the housing, heat generated by the ignitor will not be radiated properly.

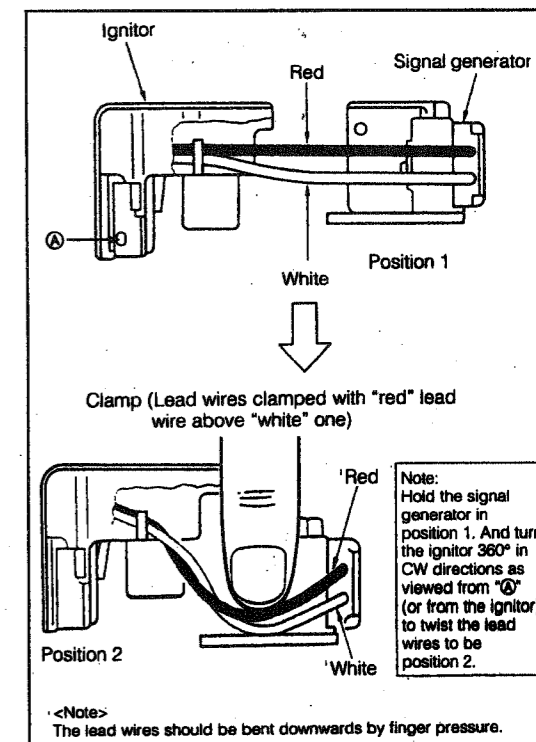

Note:
Hold the signal generator in position 1. And turn the ignitor 360° in CW directions as viewed from "A" (or from the ignitor) to twist the lead wires to be position 2.

Note:
The lead wires should be bent downwards by finger pressure.

G2IG00040-99999

(3) Tighten the attaching screws of the ignitor.

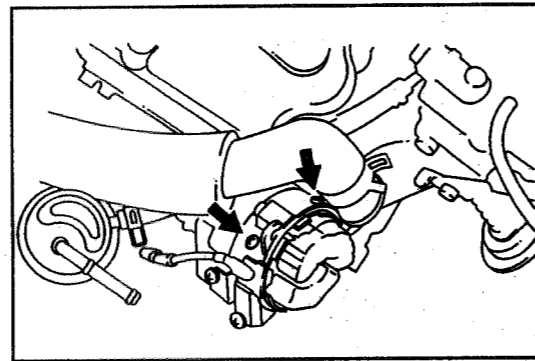

G2IG00041-99999

- 11. Install the rotor.
- 12. Install the distributor cap gasket to the distributor body.
NOTE:
• If the gasket is damaged, replace it with a new one.

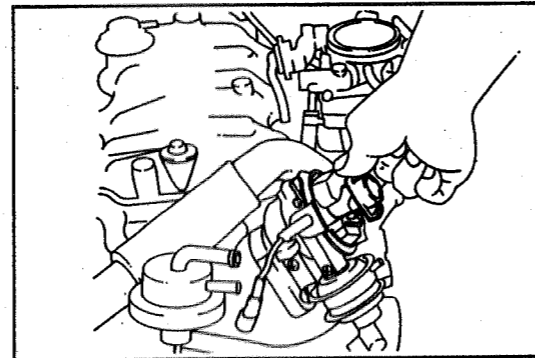

G2IG00042-99999

- 13. Install the distributor cap gasket to the distributor body.

- 14. Check the ignition timing and adjust it, as required.
(See page IG-5.)

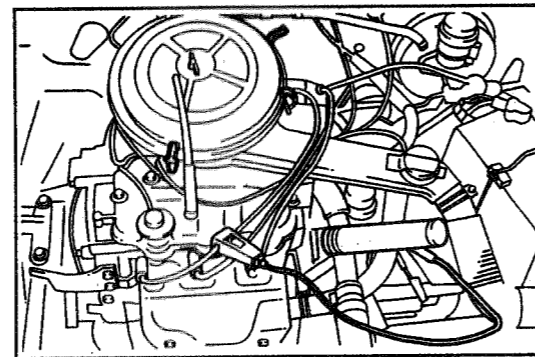

G2IG00043-99999

DISTRIBUTOR COMPONENTS

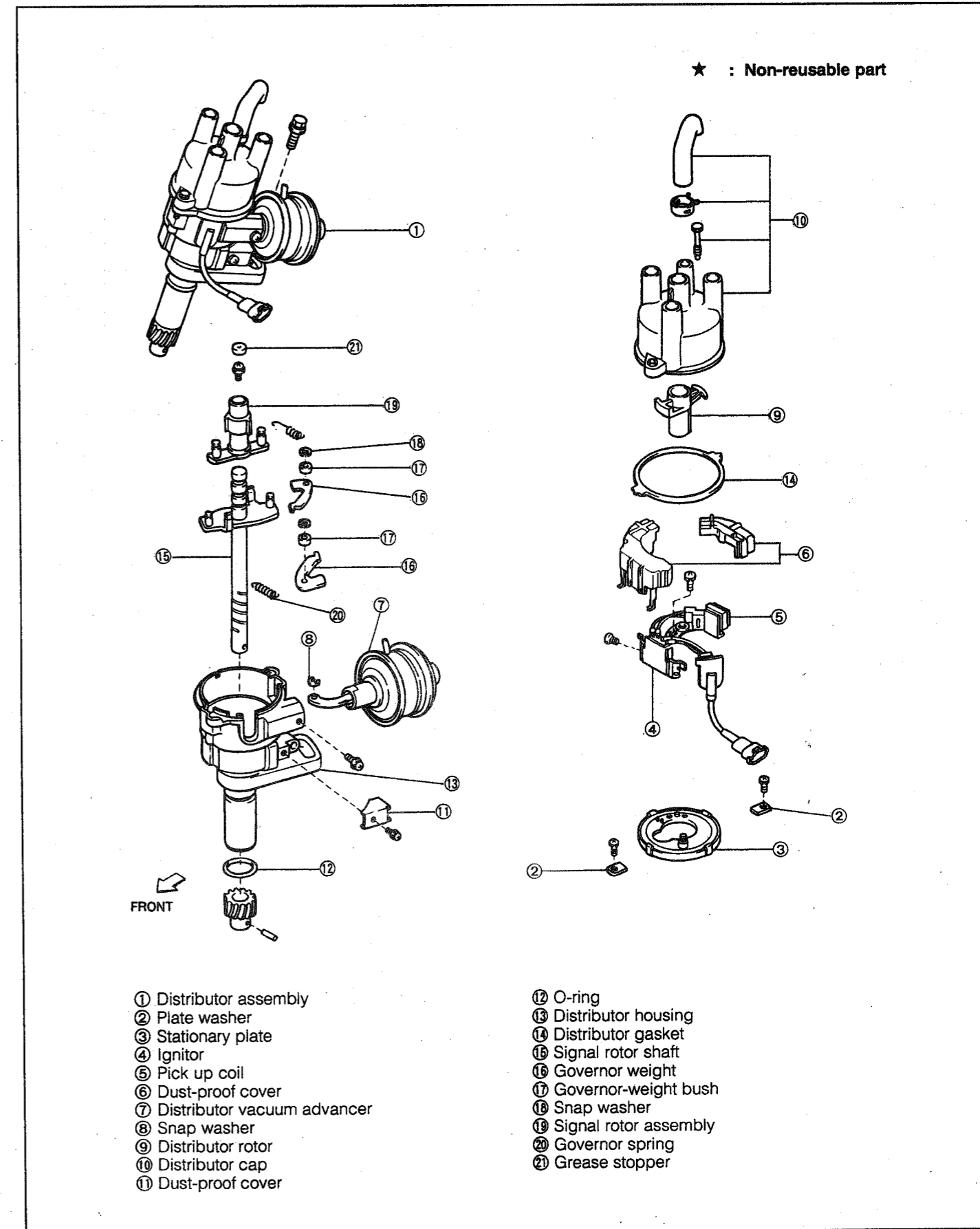

REMOVAL OF DISTRIBUTOR

1. Disconnect the battery ground cable terminal from the negative (-) terminal of the battery.
2. Disconnect the resistive cords from the distributor cap.
3. Disconnect the vacuum hoses from the vacuum advancer.
4. Disconnect the connector.
5. Remove the distributor retaining bolt.
6. Pull out the distributor from the cylinder head.

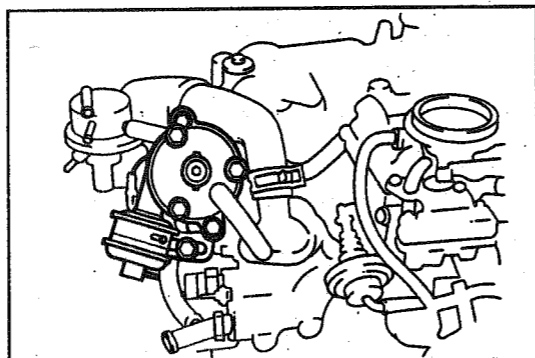

G2IG00045-99999

DISASSEMBLY OF DISTRIBUTOR

1. Remove the O-ring from the distributor housing.
2. Remove the distributor cap from the distributor housing.
3. Remove the rotor.

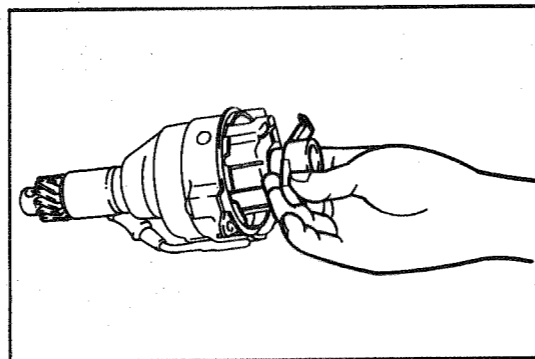

G2IG00046-99999

4. Remove the distributor cap gasket.
5. Remove the dust-proof cover.

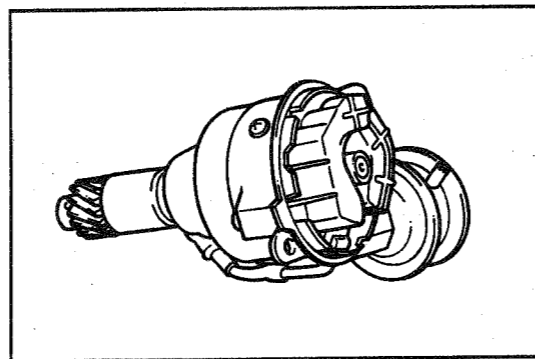

G2IG00047-99999

6. Remove the ignitor from the distributor housing by removing the two attaching screws.

NOTE:

- Be very careful not to damage the wire.

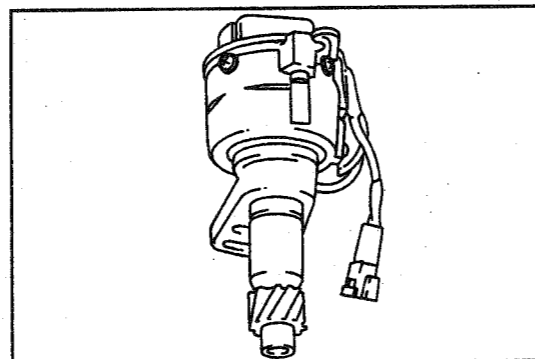

G2IG00048-99999

7. Remove the signal generator from distributor housing by removing the two attaching screws.

NOTE:

- Be very careful not to damage the wire.

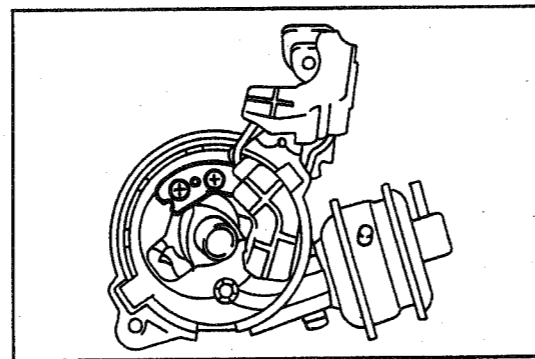

G2IG00049-99999

8. Remove the snap washer of the vacuum advancer.
9. Remove the attaching screw of the vacuum advancer.
10. Remove the vacuum advancer from the pin of the stationary plate.
11. Pull out the vacuum advancer from the distributor housing.
12. Remove the attaching screws and plate of the distributor stationary plate.
13. Remove the stationary plate from the distributor housing.

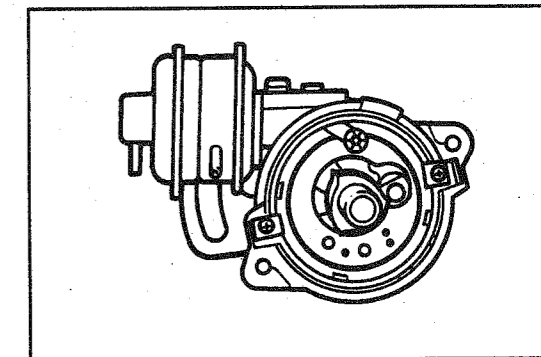

G2IG00050-99999

14. Remove the governor spring.

NOTE:

- Never reuse the removed governor springs.

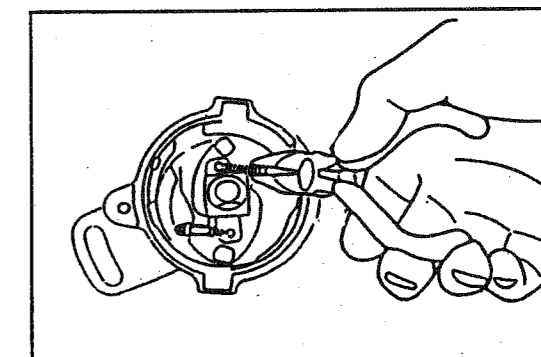

G2IG00051-99999

15. Remove the grease stopper.

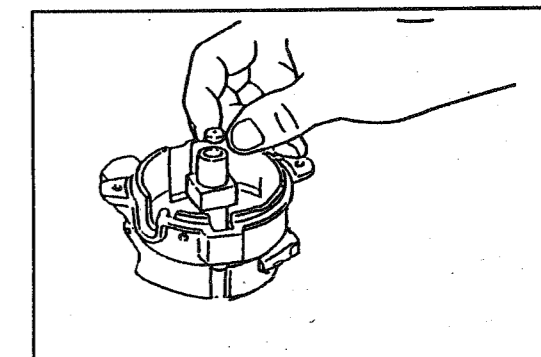

G2IG00052-99999

16. Remove the signal rotor assembly by removing the attaching screw.

17. Remove the signal rotor assembly.

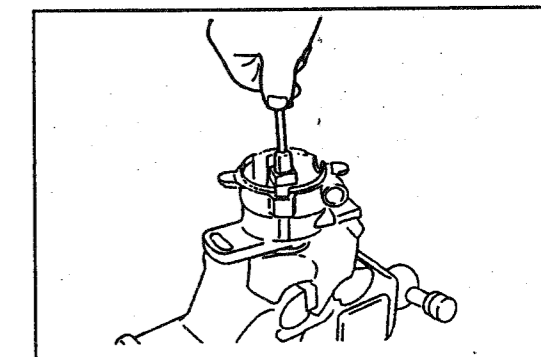

G2IG00053-99999

18. Remove the snap washer and bush of the governor weight.

19. Remove the governor weight.

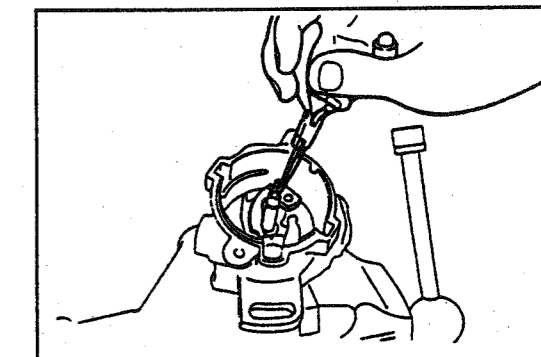

G2IG00054-99999

INSPECTION OF DISTRIBUTOR COMPONENTS

1. Inspect the stationary plate.
Check to see if the stationary inner plate rotates on the outer plate smoothly.
If the inner plate will not rotate smoothly, replace the stationary plate.

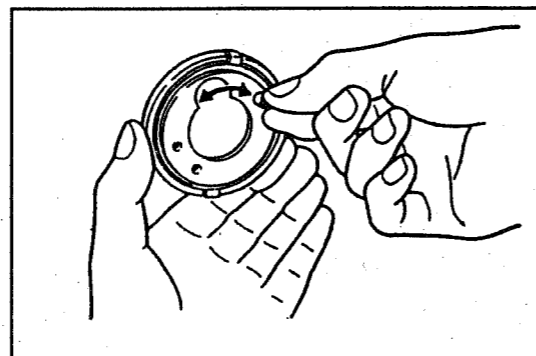

G2IG00055-99999

2. Inspection of distributor housing
 - (1) Check to see if the governor shaft rotates smoothly.
If it will not rotate smoothly, replace the distributor housing.

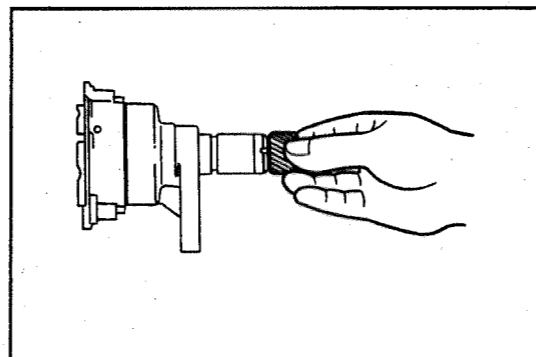

G2IG00056-99999

- (2) Check the sliding section of the governor weight for wear or damage.
Replace the distributor housing if it exhibits wear or damage.

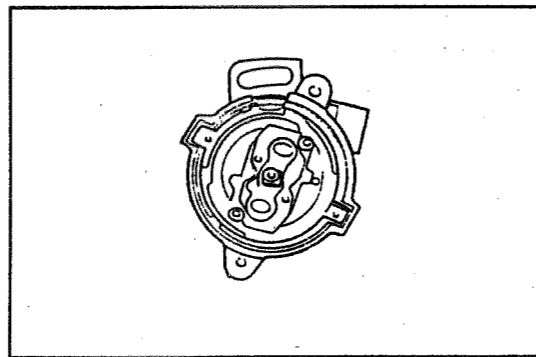

G2IG00057-99999

- (3) Check the coupling section of the governor shaft for wear or damage. Also, check to see if any excessive play is present in the turning direction.
Replace the distributor housing if it exhibits wear, damage and/or excessive play in the turning direction.

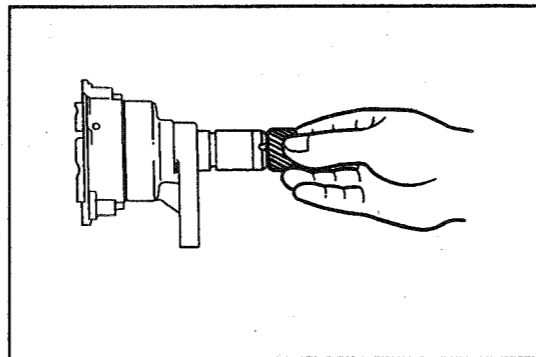

G2IG00058-99999

3. Inspection of governor weight and governor weight bush for damage or wear

- (1) Visually inspect the governor weight and governor weight bush for damage or wear.
Replace the governor weight and governor weight bush if it exhibits damage or wear.

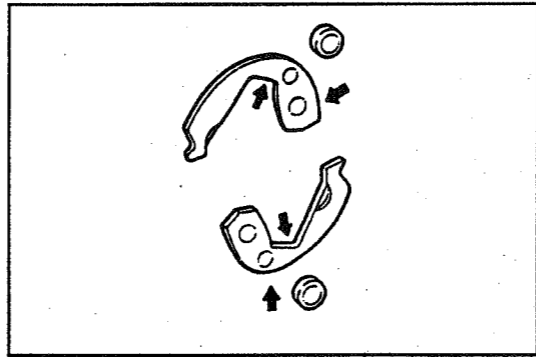

G2IG00059-99999

- (2) Install the governor weight to the governor shaft. Check to see if any excessive play is present.
If excessive play is present, replace the governor weight and/or distributor housing, as required.

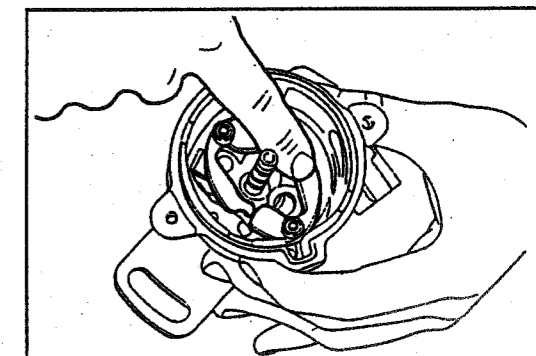

G2IG00060-99999

4. Inspection of signal rotor assembly
 - (1) Visually inspect the signal rotor for damage.
Replace the signal rotor assembly if it exhibits damage.
 - (2) Check the pin section of the signal rotor assembly for wear or damage.
Replace the signal rotor assembly if the pin section exhibits wear or damage.

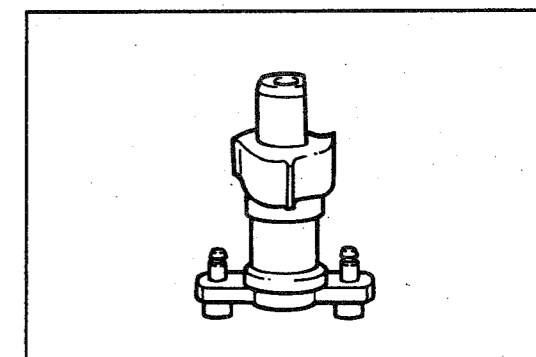

G2IG00061-99999

- (3) Install the signal rotor assembly to the governor shaft temporarily. Check to see if the signal rotor is tilted.
Replace the signal rotor assembly and/or distributor housing if it is tilted.

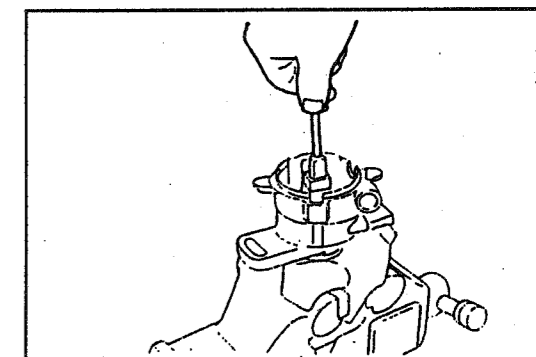

G2IG00062-99999

5. Inspection of vacuum advancer
 - (1) Gradually apply a negative pressure to the main diaphragm of the vacuum advancer. Ensure that the rod of the vacuum advancer is drawn into the diaphragm room side, corresponding to the negative pressure.
Replace the vacuum advancer if the rod will not be drawn.

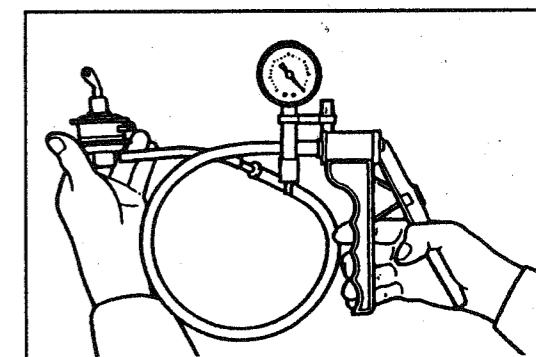

G2IG00063-99999

- (2) Gradually apply a negative pressure to the sub diaphragm of the vacuum advancer. Ensure that the rod of the vacuum advancer is drawn into the diaphragm room side, corresponding to the negative pressure.
Replace the vacuum advancer if the rod will not be drawn.

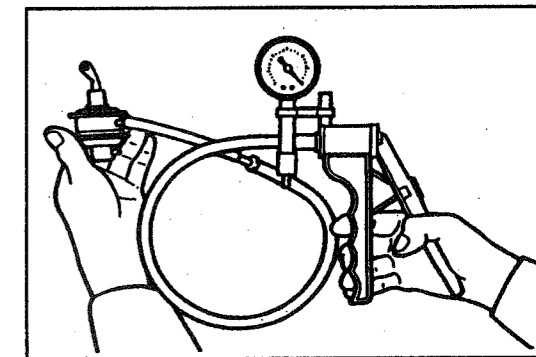

G2IG00064-99999

6. Inspection of rotor
Check the center carbon contacting surface and electrode for damage, such as wear, electronic corrosion and cracks. If the surface or electrolytic exhibits damage, replace the rotor, as required.

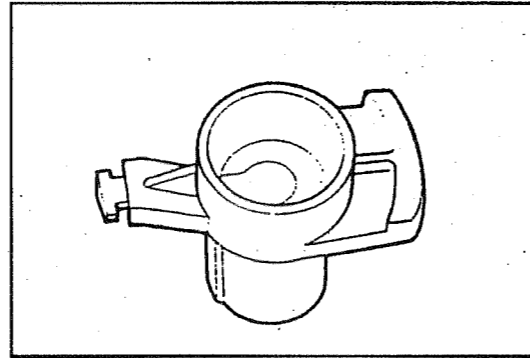

G2IG00065-99999

7. Inspection of distributor cap
Check the distributor cap for cracks. Also, check the electrode and center carbon for damage, such as wear. Replace the distributor cap if the cap, electrode or carbon exhibits damage.

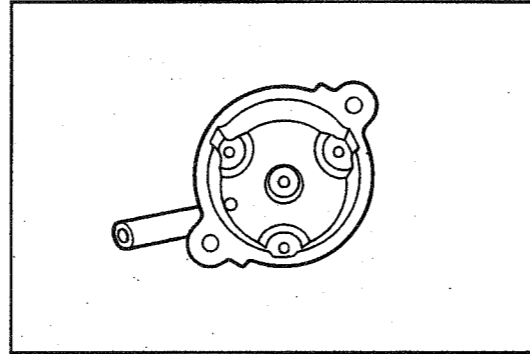

G2IG00066-99999

ASSEMBLY OF DISTRIBUTOR

1. Install the governor weight to the distributor housing. Install the governor weight bush and snap washer.
NOTE:
• Apply a thin film of high-temperature grease to the sliding section.

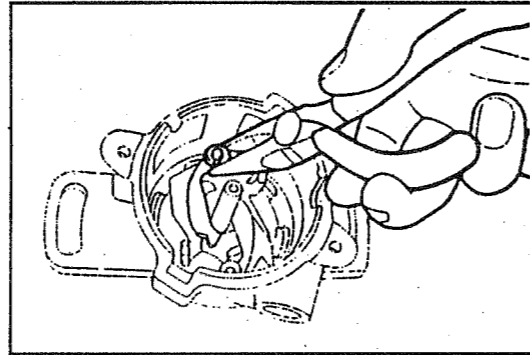

G2IG00067-99999

2. Installation of signal rotor assembly
(1) Apply a thin film of high-temperature grease to the sliding section of the signal rotor assembly.
(2) Install the signal rotor assembly to the distributor housing.

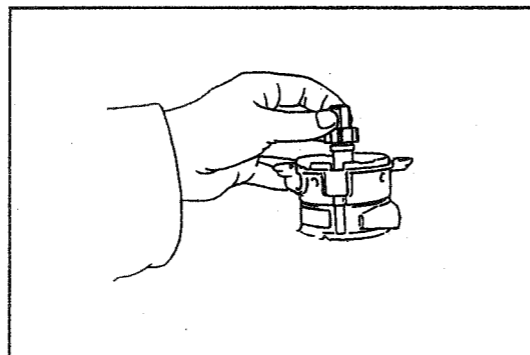

G2IG00068-99999

- (3) Tighten the attaching screw.

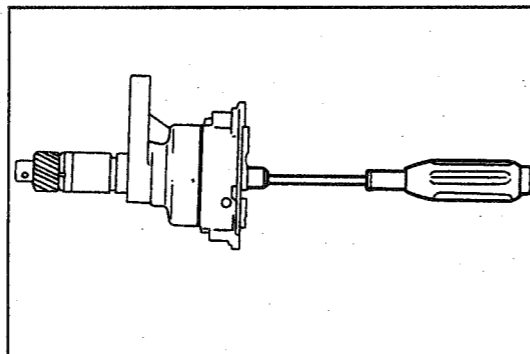

G2IG00069-99999

- (4) Pack high-temperature grease in the signal rotor assembly.

- (5) Install the grease stopper.

NOTE:

- Wipe off any excess grease which has oozed out.

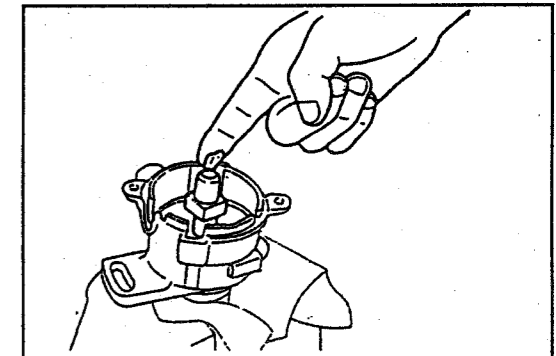

G2IG00070-99999

3. Install new governor springs to the governor weight and signal rotor assembly.

NOTE:

- Be very careful not to distort the governor spring during the installation.

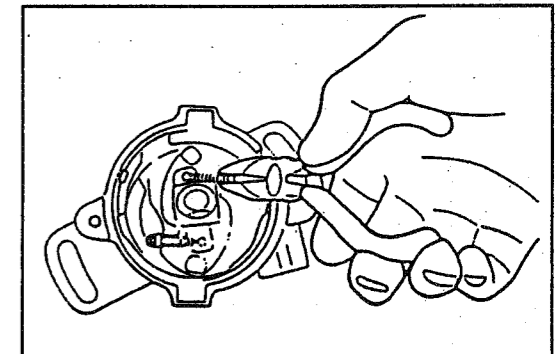

G2IG00071-99999

4. Install the stationary plate, lining up the cut-out section of the distributor housing.

5. Screw the stationary plate installation seat and stationary plate with screws.

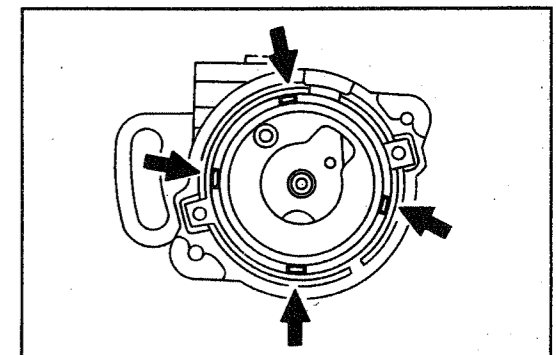

G2IG00072-99999

6. Insert the vacuum advancer into the distributor housing.
7. Connect the vacuum advancer to the pin of the stationary inner plate.
8. Install the snap washer.
9. Align the screw hole of the vacuum advancer with the screw hole of the distributor housing.
10. Tighten the attaching screw.

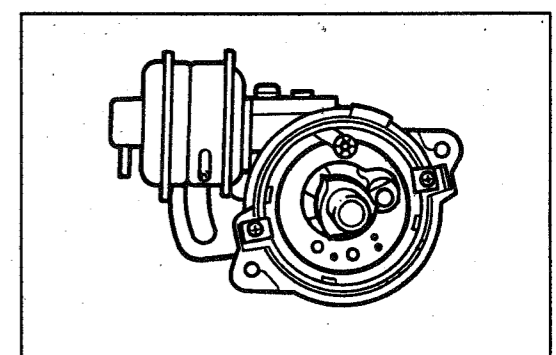

G2IG00073-99999

11. Installation of signal generator
Install the signal generator to the stationary plate. Adjust the air gap in such a way that the air gap in relation to the signal rotor is 0.2 - 0.4 mm. (See page IG-14.)

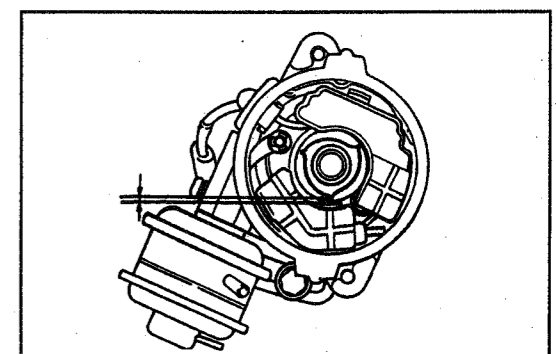

G2IG00074-99999

12. Install the ignitor.

13. Install the dust-proof cover.
14. Install a new gasket.

15. Install the rotor.
16. Install the distributor cap.
17. Install a new O-ring to the distributor housing.

INSTALLATION OF DISTRIBUTOR

1. Set the piston of cylinder No. 1 to BTDC 5° under the compression stroke.

NOTE:

- This position can be confirmed by making sure that the timing marks are aligned with each other and that the valve rocker arms for the cylinder No. 1 are in a free state by removing the oil filler cap.

2. Set the distributor shaft in such a way indicated in the right figure that the drilled mark at the forward end of the distributor drive gear is aligned with the indicator mark on the distributor body.

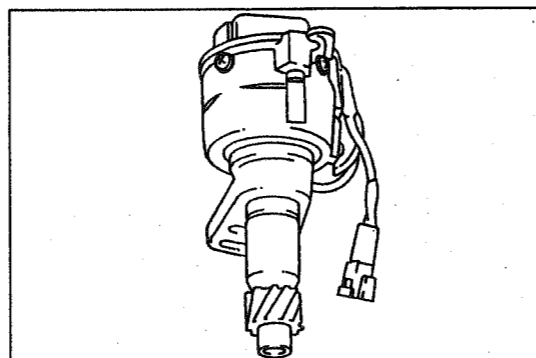

G2IG00075-99999

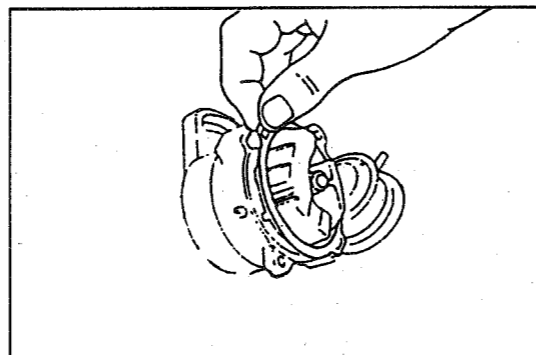

G2IG00076-99999

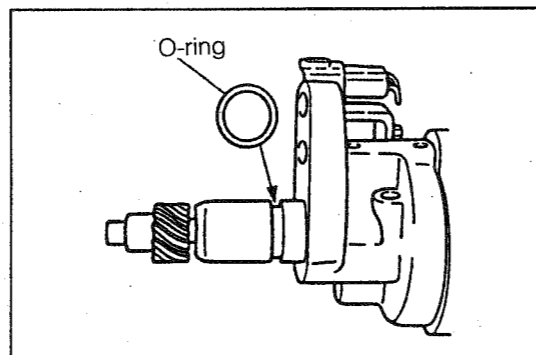

G2IG00077-99999

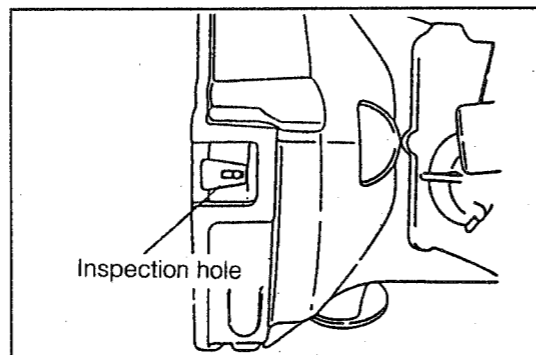

G2IG00078-99999

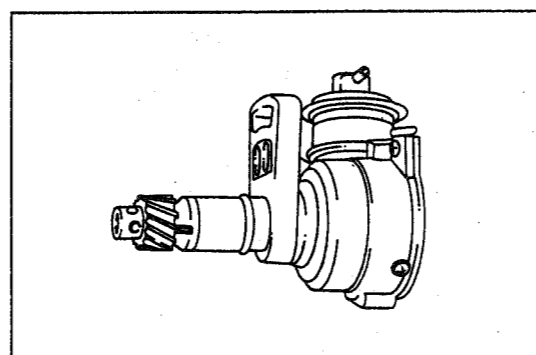

G2IG00079-99999

3. Insert the distributor assembly into the distributor housing in such a way that the split line of the distributor body may be aligned with the embossed line of the distributor housing.

4. Temporarily tighten the distributor retaining bolt.

NOTE:

- The final tightening should be performed after the check and adjustment of the ignition timing have been completed.

5. Connect the connector.
6. Connect the vacuum hoses to the vacuum advancer.
7. Connect the resistive cords to the distributor cap.

8. Connect the battery ground cable terminal to the negative (-) terminal of the battery.

9. Check and adjustment of ignition timing. (See page IG-5.)
10. Ensure that no oil leakage is present. Repair any leaky point.

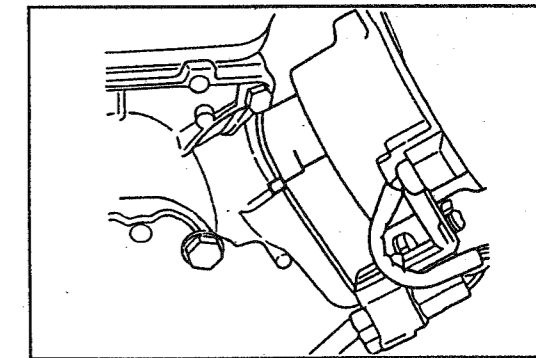

G2IG00080-99999

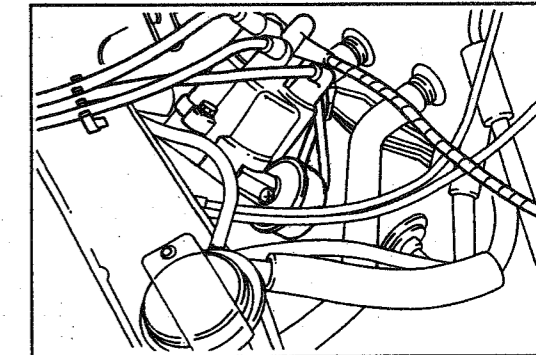

G2IG00081-99999

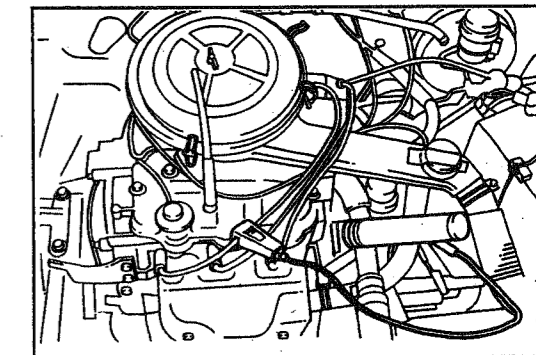

G2IG00082-99999

SERVICE SPECIFICATIONS

Ignition coil	Resistance (at 20°C) Primary coil	(Ω)	1.35 - 1.65
	Secondary coil	(kΩ)	22 - 30
Resistive cord	Resistance	(kΩ)	less than 15
Spark plug	Recommended spark plug gap	(mm)	
	NIPPONDENSO NGK	W16EX(R)-U BP(R)5EY	0.7 - 0.8 0.8 - 0.9
Distributor	Ignition timing	(B.T.D.C. °/rpm)	5.0 ± 2.0 / Idle speed
	Air gap	(mm)	0.2 - 0.4



G2IG00083-00000

TIGHTENING TORQUE

Tightening components	Tightening torque			Remarks
	N-m	kgf-m	ft-lb	
Distributor × Cylinder head	14.7 - 21.6	1.5 - 2.2	10.8 - 15.9	
Spark plug × Cylinder head	14.7 - 21.6	1.5 - 2.2	10.8 - 15.9	

G2IG00084-00000

SSTs

Shape	Part number	Part name	Remarks
	09258-00030-000	Plug set	
	09991-87604-000	Tachometer pulse pickup wire	

G2IG00085-99999