

# **DAIHATSU**

# **G202**

CB-Engine

**LU**

## **LUBRICATION SYSTEM**

<b>OIL PRESSURE CHECK .....</b>	<b>LU- 2</b>
<b>ENGINE OIL CHANGE &amp; OIL FILTER REPLACEMENT .....</b>	<b>LU- 3</b>
<b>OIL PUMP .....</b>	<b>LU- 5</b>
<b>COMPONENTS .....</b>	<b>LU- 5</b>
<b>REMOVAL OF OIL PUMP .....</b>	<b>LU- 5</b>
<b>DISASSEMBLY OF OIL PUMP .....</b>	<b>LU- 7</b>
<b>INSPECTION OF OIL PUMP .....</b>	<b>LU- 8</b>
<b>INSPECTION OF DRIVE SHAFT     SPROCKET .....</b>	<b>LU- 9</b>
<b>ASSEMBLY OF OIL PUMP .....</b>	<b>LU- 9</b>
<b>INSTALLATION OF OIL PUMP .....</b>	<b>LU- 9</b>
<b>APPENDIX .....</b>	<b>LU-13</b>
<b>SSTs .....</b>	<b>LU-13</b>
<b>TIGHTENING TORQUE .....</b>	<b>LU-13</b>
<b>SERVICE SPECIFICATION .....</b>	<b>LU-13</b>
<b>TROUBLE SHOOTING .....</b>	<b>LU-13</b>

G2LU00001-00000

**NO. 9188**

**OIL PRESSURE CHECK**

1. Oil quality check  
Check the oil for deterioration, ingress of water, discoloring or dilution.  
If oil quality is poor, change the oil.  
Use API grade SF or SF/CC multigrade viscosity, fuel-efficient oil. (See page LU-4.)
  
2. Oil level check  
The oil level should be between the L and F levels on the dipstick.  
If the level is low, check to see if any oil leakage is present.  
Add oil to the F level.
  
3. Remove the oil pressure switch.
  
4. Install the oil pressure gauge.  
**NOTE:**
  - The pressure gauge is available as a SST.  
SST: 09268-87702-000
  
5. Starting engine  
Start the engine and warm it to the normal operating temperature.
  
6. Measurement of oil pressure  
At Idle Speed: More than 29.42 kPa  
(0.3 kgf/cm<sup>2</sup>, 4.27 psi)  
At 3000 rpm: 245.17 - 490.33 kPa  
(2.5 - 5.0 kgf/cm<sup>2</sup>, 35.56 - 71.12 psi)
  
7. Remove the oil pressure gauge. Then, install the oil pressure switch. Connect the connector of the oil pressure switch.  
**NOTE:**
  - After the pressure switch has been reinstalled, make sure that no oil leakage is present.

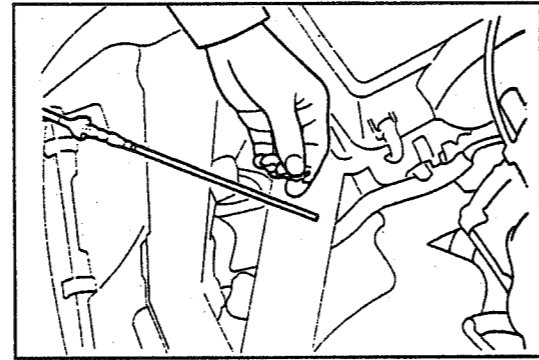

G2LU00002-99999

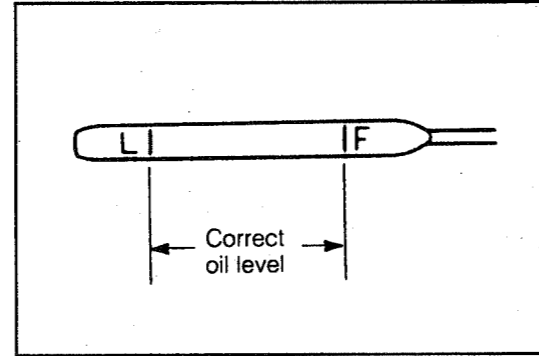

G2LU00003-99999

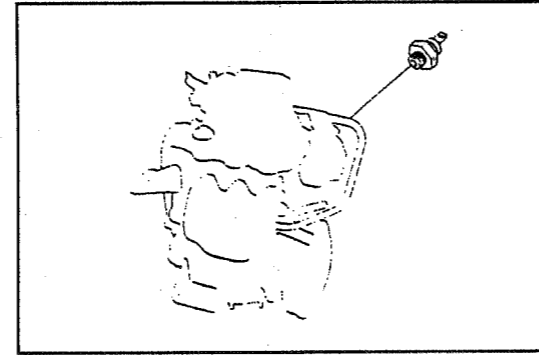

G2LU00004-99999

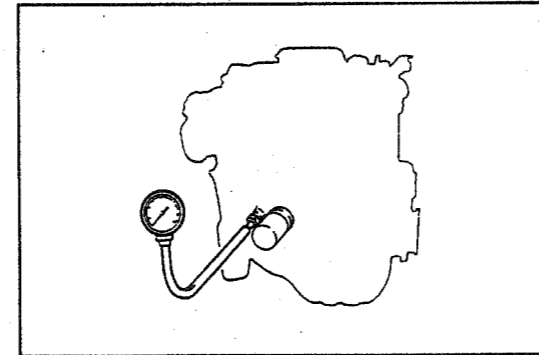

G2LU00005-99999

**ENGINE OIL CHANGE & OIL FILTER REPLACEMENT**

1. Drain the engine oil as follows.  
Remove the oil drain plug, and allow the oil to drain into an adequate container.  
**CAUTION:**
  - When the oil is still hot, care must be exercised to avoid getting scalded.
  
2. Oil filter replacement  
(1) Remove the oil filter, using the following SST.  
SST: 09228-87201-000  
  
**NOTE:**
  - Since the oil flows out during the replacement, receive the oil with an adequate container.  
(2) Inspect and clean the oil filter installation surface.  
  
(3) Apply clean engine oil to the gasket of a new oil filter.
  
- (4) Installation of oil filter  
① Screw in the oil filter lightly by hand until the oil seal surface contacts the oil cooler.  
② Tighten the oil filter one more turn, using the SST.  
SST: 09228-87201-000

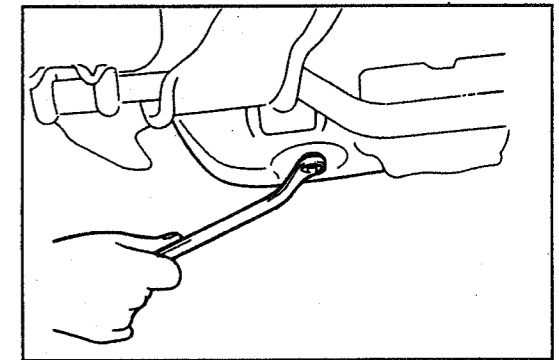

G2LU00006-99999

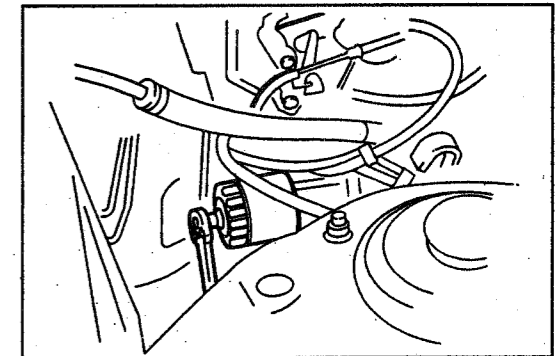

G2LU00007-99999

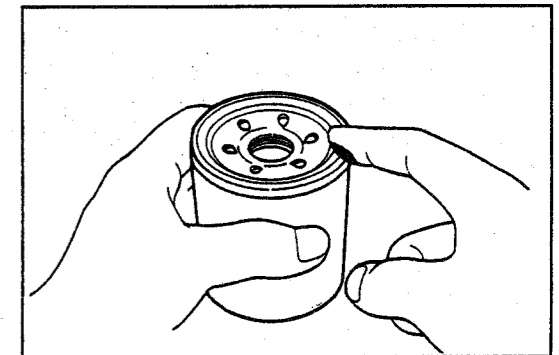

G2LU00008-99999

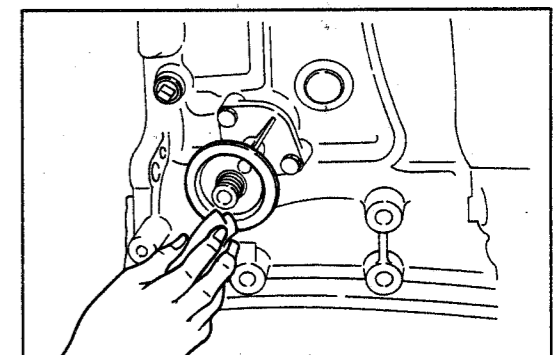

G2LU00009-99999

3. Filling engine oil

- (1) Clean the oil drain plug. Install it with a new gasket interposed.
- (2) Fill the engine with new oil. The oil should be API grade SF or SF/CC multigrade viscosity, fuel-efficient oil.

Oil Capacity:

When only engine oil is changed: 2.7 liter

When engine oil is changed and oil filter is replaced: 3.0 liter

After engine has been overhauled or when engine oil has been drained completely from engine:

3.2 liter

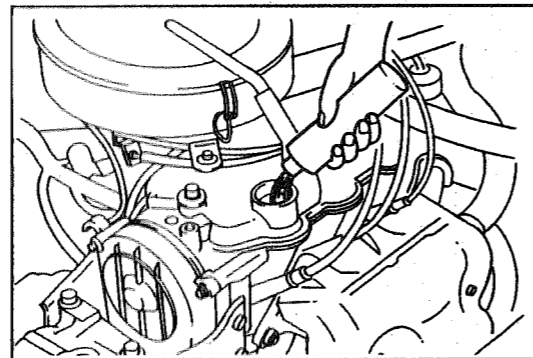

G2LU00010-99999

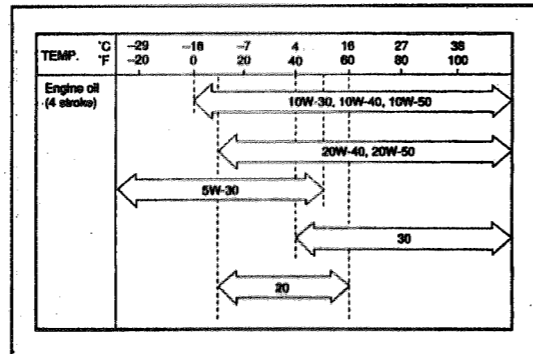

G2LU00000-99999

4. Oil leakage check

- (1) Warm up the engine.
- (2) Check to see if any oil leakage is present.  
If any oil leakage is present, repair leaky points.

G2LU00011-00000

OIL PUMP COMPONENTS

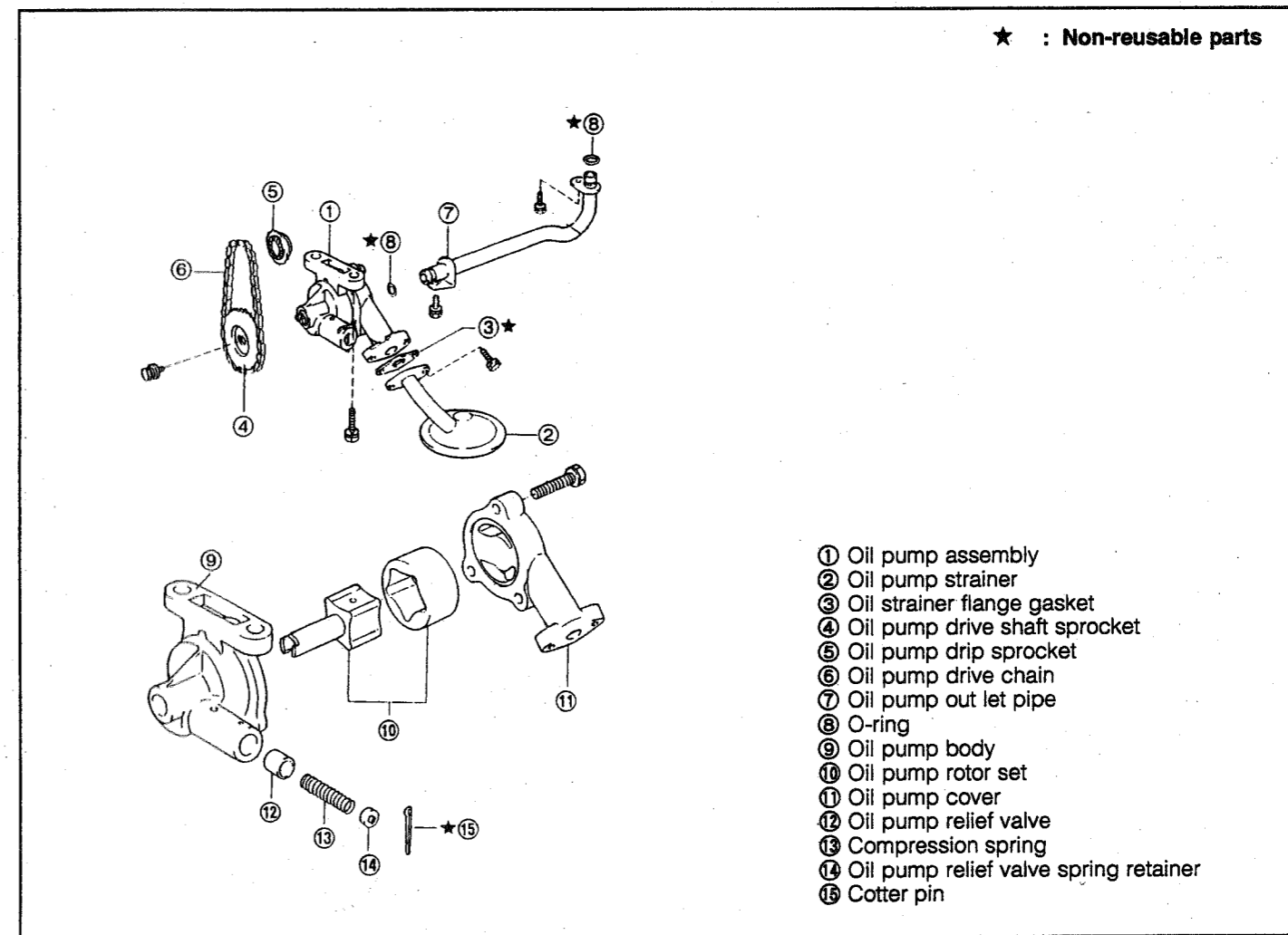

- ① Oil pump assembly
- ② Oil pump strainer
- ③ Oil strainer flange gasket
- ④ Oil pump drive shaft sprocket
- ⑤ Oil pump drip sprocket
- ⑥ Oil pump drive chain
- ⑦ Oil pump out let pipe
- ⑧ O-ring
- ⑨ Oil pump body
- ⑩ Oil pump rotor set
- ⑪ Oil pump cover
- ⑫ Oil pump relief valve
- ⑬ Compression spring
- ⑭ Oil pump relief valve spring retainer
- ⑮ Cotter pin

G2LU00012-99999

REMOVAL OF OIL PUMP

1. Disconnect the battery ground cable from the negative (-) terminal of the battery.
2. Drain the engine oil as follows.  
Remove the oil drain plug, allow the oil to drain into a clean container.

CAUTION:

- When the oil is still hot, care must be exercised to avoid getting scalded.

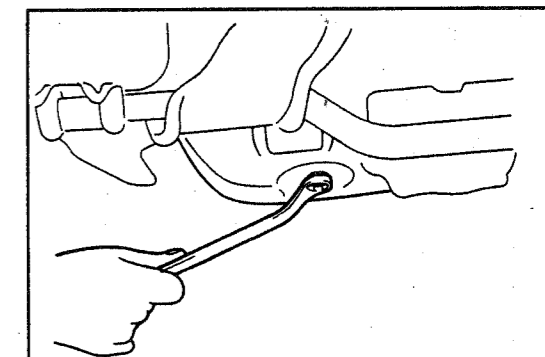

G2LU00013-99999

3. Jack up the vehicle at the front. Place safety stands in position.

CAUTION:

- Place wheel chocks at the rear wheels.

4. Remove the engine right side undercover.

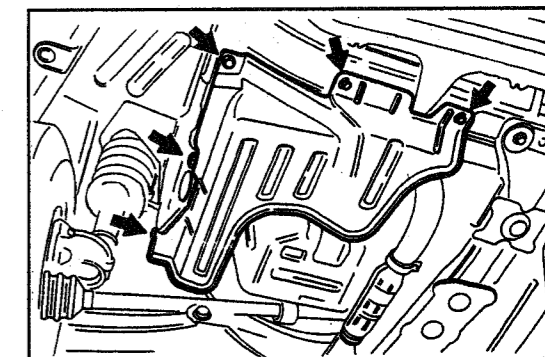

G2LU00014-99999

5. Removal of front exhaust pipe
- (1) Remove the engine lower mounting No. 2 member.
  - (2) Remove the lower arm bracket connecting rod.
  - (3) Remove the attaching nuts of the front exhaust pipe to the exhaust manifold.

**CAUTION:**

- Do not reuse the gasket and attaching nuts.

- (4) Remove the attaching nuts of the front exhaust pipe to the rear exhaust pipe.

**CAUTION:**

- Do not reuse the gasket and attaching nuts.

- (5) Remove the front exhaust pipe from the muffler support.

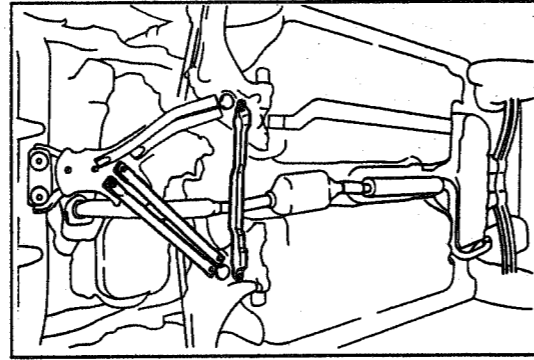

G2LU00015-99999

6. Remove the exhaust manifold stay.
7. Remove the stiffener.
8. Remove the clutch housing under cover.

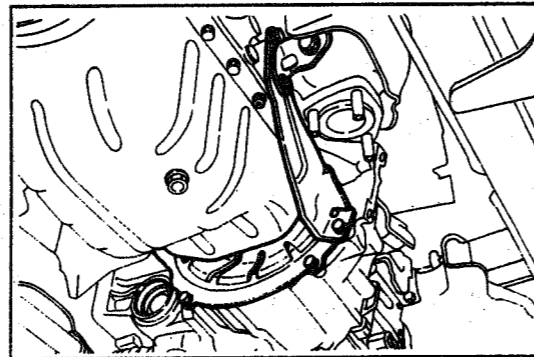

G2LU00016-99999

9. Removal of oil pan
- (1) Remove the nuts and bolts.
  - (2) Remove the oil pan.

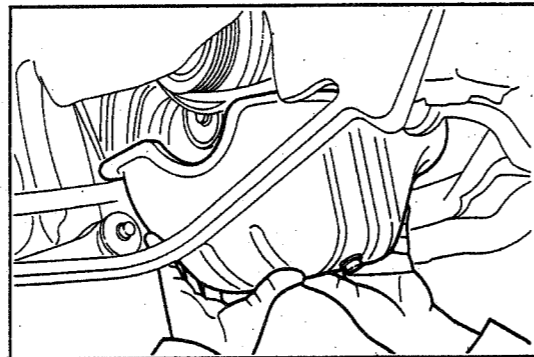

G2LU00017-99999

10. Remove the oil strainer.

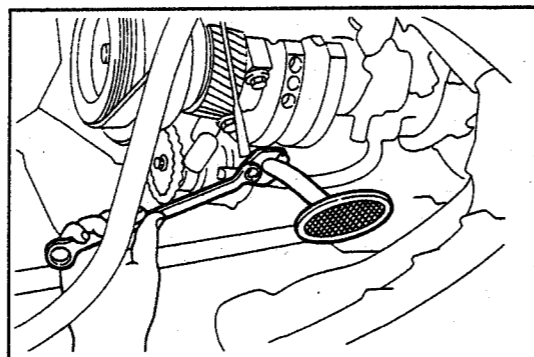

G2LU00018-99999

11. Remove the oil pump drive shaft sprocket.

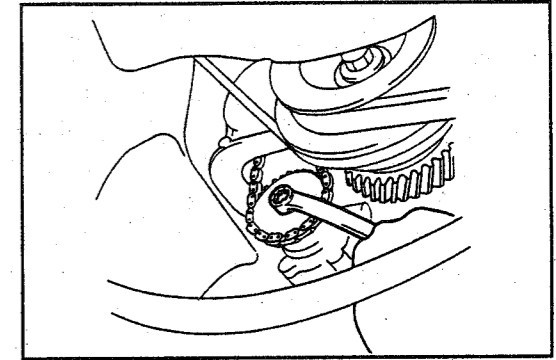

G2LU00019-99999

12. Remove the oil pump with the oil pump outlet pipe.
13. Remove the oil pump outlet pipe from the oil pump.

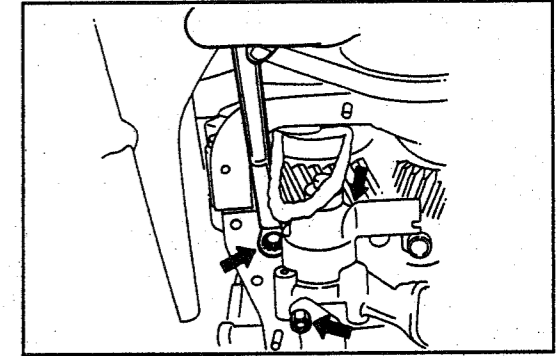

G2LU00020-99999

**DISASSEMBLY OF OIL PUMP**

(See page LU-5.)

1. Remove the oil pump cover.

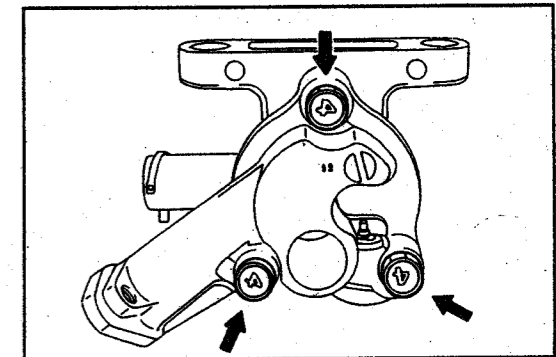

G2LU00021-99999

2. Remove the oil pump rotor set from the pump body.

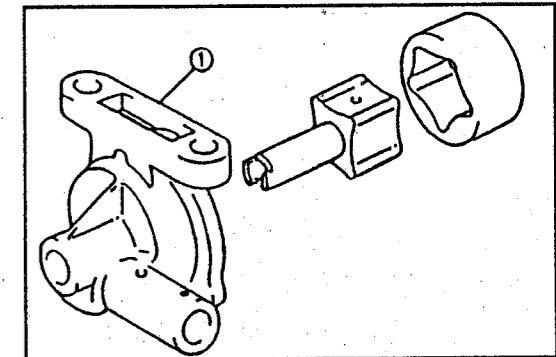

G2LU00022-99999

3. Remove the cotter pin, oil pump relief valve spring retainer, compression spring and oil pump relief valve.

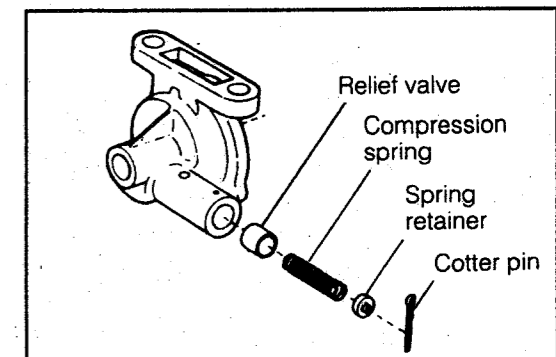

G2LU00023-99999

**INSPECTION OF OIL PUMP**

1. Measurement of body clearance  
Measure the clearance between the driven rotor and the pump body, using a feeler gauge.  
Clearance: 0.1 - 0.3 mm (0.0039 - 0.0118 inch)

If the clearance is greater than the specified clearance, replace the rotor set or pump assembly.

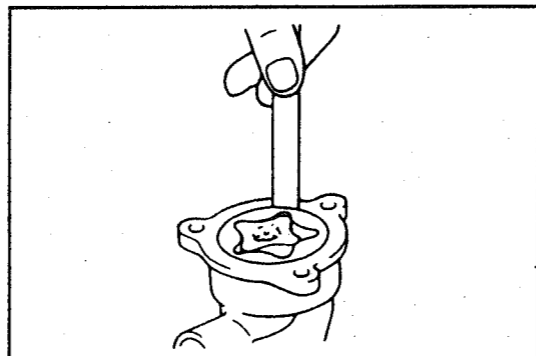

G2LU00024-99999

2. Measurement of tip clearance  
Measure tip clearance between the both rotor tips, using a feeler gauge.  
Maximum Clearance: 0.25 mm (0.0098 inch)

If the clearance is greater than the maximum clearance, replace the oil pump rotor set.

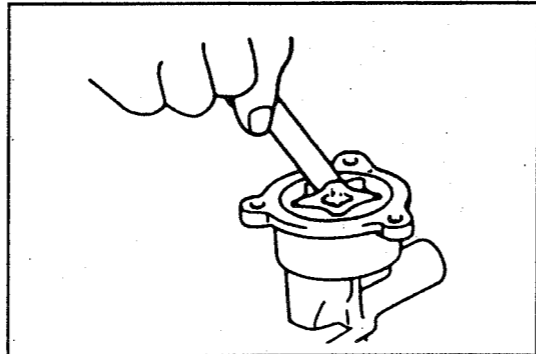

G2LU00025-99999

3. Measurement of side clearance  
Measure the side clearance between the pump body and the rotor set, using a feeler gauge and flat block.  
Maximum Clearance: 0.20 mm (0.0079 inch)

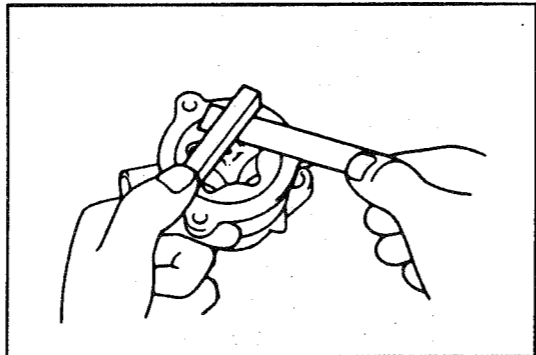

G2LU00026-99999

4. Measurement of shaft clearance  
(1) Measure the inner diameter of the pump body shaft hole and the outer diameter of the rotor shaft, using a micrometer and a dial gauge. Determine the shaft clearance by subtracting the outer diameter from the inner diameter.  
Clearance: 0.045 - 0.1 mm (0.0018 - 0.0039 inch)

If the clearance is greater than the specified clearance, replace the oil pump assembly.

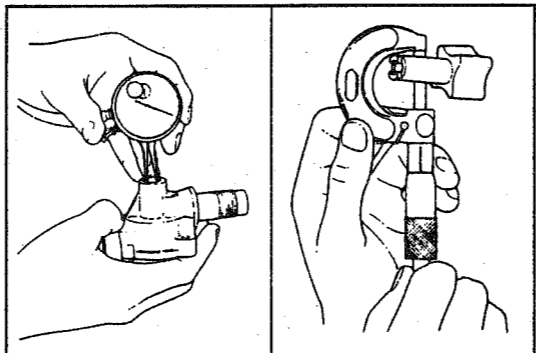

G2LU00027-99999

5. Inspection of relief valve, compression spring and retainer for damage  
(1) Check the body sliding surface of the relief valve sliding surface of the oil pump body for damage. If this surface is damaged, replace the oil pump assembly. If the body sliding surface of the relief valve alone is damaged, replace the relief valve.  
(2) Visually inspect the compression spring and retainer for damage. If any damage is present, replace the compression spring and/or retainer.

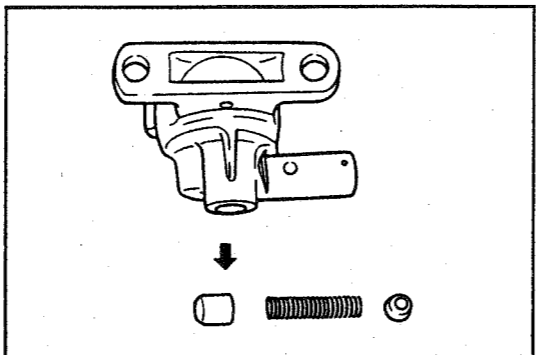

G2LU00028-99999

**INSPECTION OF DRIVE SHAFT SPROCKET**

Visually inspect the drive shaft sprocket for cracks or damage. If the sprocket exhibits any damage, replace it.

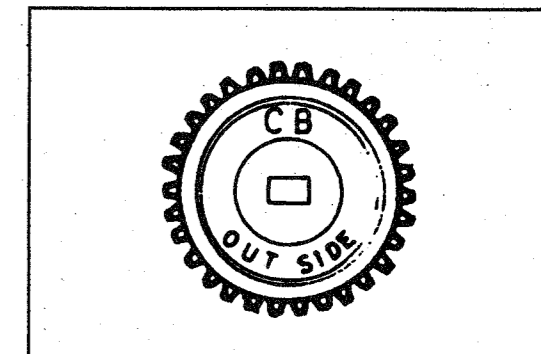

G2LU00029-99999

**ASSEMBLY OF OIL PUMP**

(See page LU-5.)

1. Installation of relief valve  
(1) Insert the relief valve, compression spring and relief valve retainer into the pump body.  
(2) Push the relief valve spring retainer into position, using a screwdriver or the like. Insert the cotter pin and open its legs into an anchor shape.

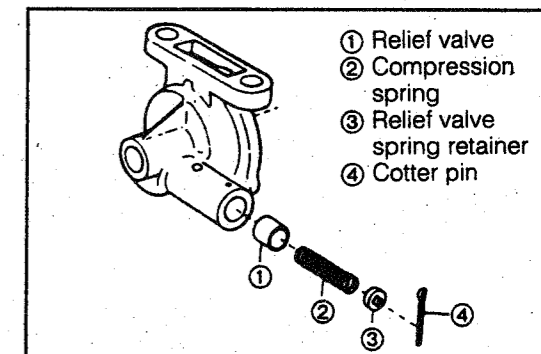

G2LU00030-99999

2. Installation of rotor set  
(1) Install the rotor set into the pump body in such a way that both of the punched marks face toward you.

**NOTE:**

- Coat each sliding part with engine oil.

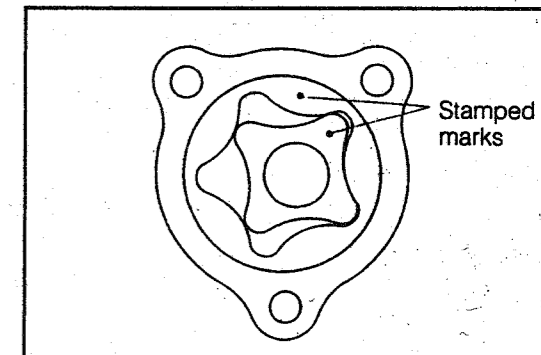

G2LU00031-99999

- (2) Install the oil pump cover with three bolts. Torque the bolts.  
Tightening Torque: 3.9 - 6.9 N·m  
(0.4 - 0.7 kgf-m, 2.9 - 5.1 ft-lb)

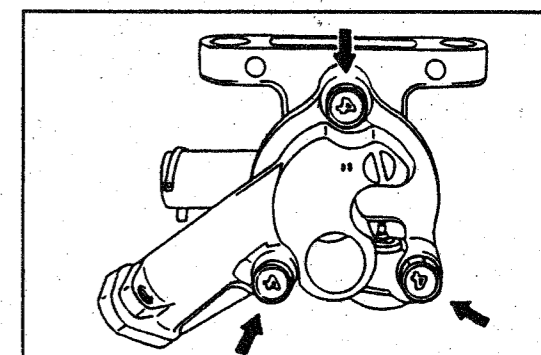

G2LU00032-99999

**INSTALLATION OF OIL PUMP**

1. Installation of oil pump  
(1) Replace the O-ring of the outlet pipe with a new one.  
(2) Apply engine oil to the O-ring of the outlet pipe. Insert the outlet pipe into the oil pump.

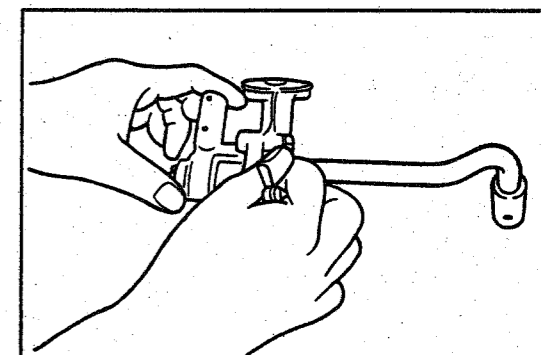

G2LU00033-99999

(3) Install the oil pump with the outlet pipe to the cylinder block by tightening the three bolts.

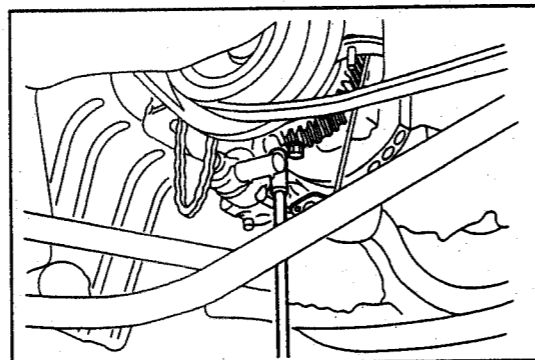

G2LU00034-99999

(4) Tighten the bolt attaching the outlet pipe to the oil pump.

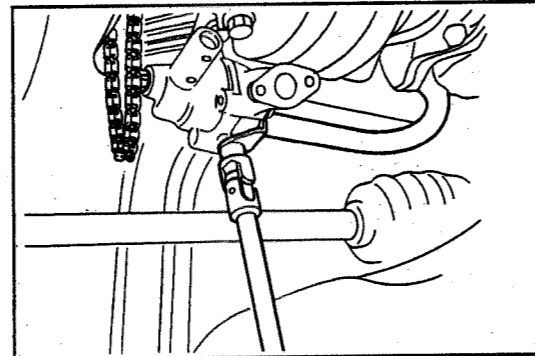

G2LU00035-99999

2. Installation of oil strainer  
Install the oil strainer to the oil pump with a new gasket interposed.

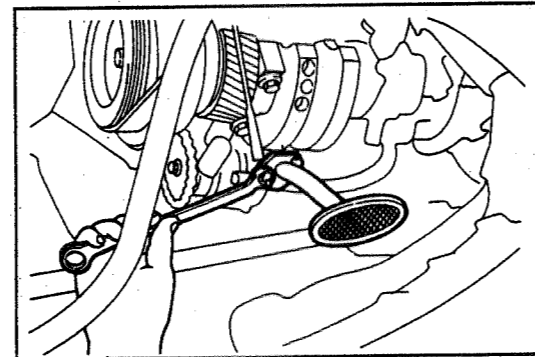

G2LU00036-99999

3. Installation of oil pump drive shaft sprocket to oil pump drive shaft  
Install the oil pump sprocket to the drive chain. Insert it into the oil pump shaft. Tighten the bolts.

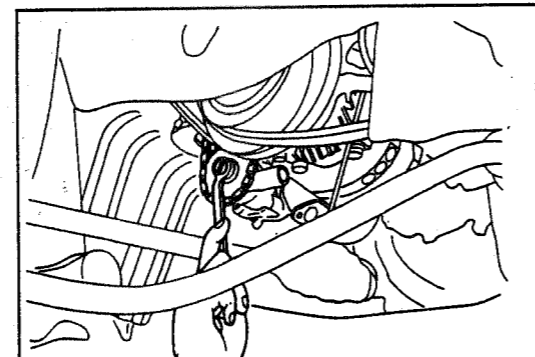

G2LU00037-99999

4. Check of oil pump chain for deflection  
Measure the deflection of the oil pump drive chain by pushing the center of the chain between the sprockets with your finger.

**Deflection Limit: 7.0 mm (0.276 inch)**

If the deflection exceeds the limit, replace the drive chain and sprocket.

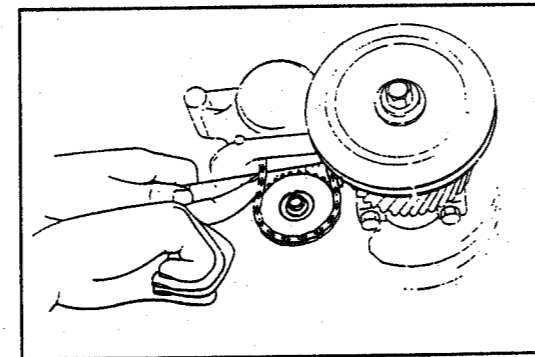

G2LU00038-99999

5. Installation of oil pan  
(1) Remove any trace of the sealing bond from the oil pan and cylinder block.  
(2) Apply silicon bond to the cylinder block at the points indicated in the right figure.  
**Sealer to be Used: Silicon Bond**

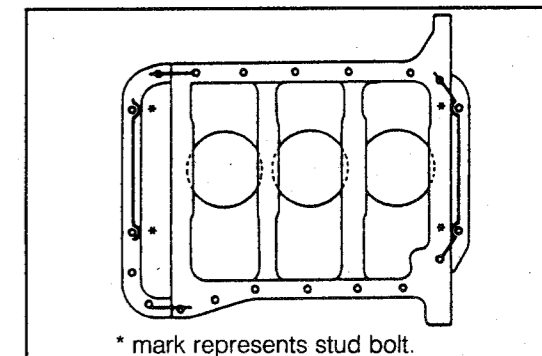

\* mark represents stud bolt.

G2LU00039-99999

(3) Apply silicon bond to the new oil pan gasket at the points indicated in the right figure.  
**Sealer to be Used: Silicon Bond**

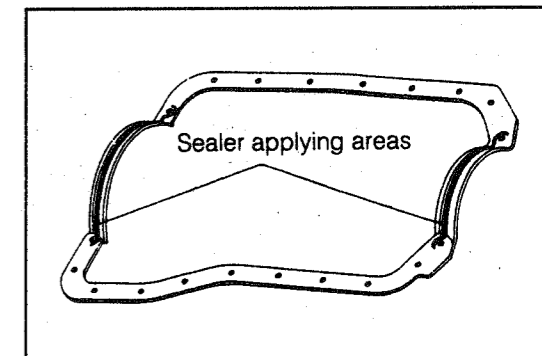

G2LU00040-99999

(4) Install the oil pan gasket applied with silicon bond to the cylinder block, aligning with the stud bolts at the cylinder block.  
(5) Install the oil pan, aligning with the stud bolts at the cylinder block.  
(6) Install the oil pan bolts and nuts in the sequence indicated in the right figure.  
**Tightening Torque: 3.9 - 6.9 N·m**  
**(0.4 - 0.7 kgf·m, 2.9 - 5.1 ft·lb)**

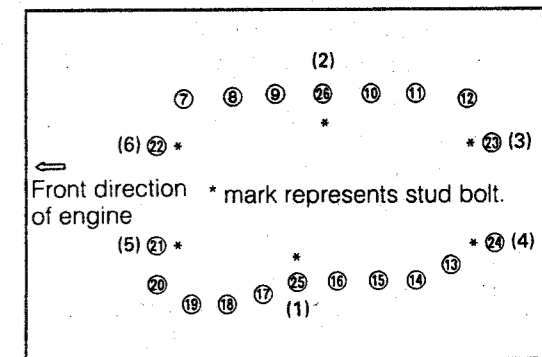

\* mark represents stud bolt.

G2LU00041-99999

**NOTE:**

- The numerals in ( ) in the right figure denote the sequence of the temporal tightening for the stud bolt nuts.

6. Install the clutch housing under cover to the transmission.  
**Tightening Torque: 14.7 - 21.6 N·m**  
**(1.5 - 2.2 kgf·m, 10.8 - 47.0 ft·lb)**

7. Install the stiffener and manifold stay.  
**Tightening Torque: 29.4 - 44.1 N·m**  
**(3.0 - 4.5 kgf·m, 21.7 - 32.5 ft·lb)**

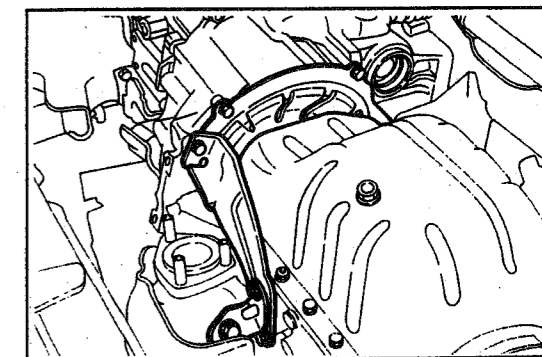

G2LU00042-99999

8. Installation of the front exhaust pipe
  - (1) Connect the front exhaust pipe to the exhaust manifold with the new gasket and new attaching nuts.
  - (2) Tighten the attaching nuts to the specified torque:  
Tightening Torque: 49.0 - 74.5 N-m  
(5.0 - 7.6 kgf-m, 36.2 - 55.0 ft-lb)

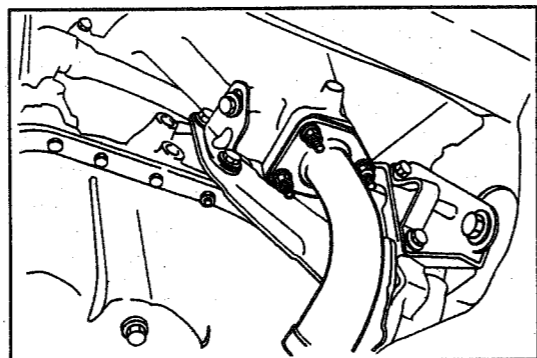

G2LU00043-99999

- (3) Connect the front exhaust pipe to the muffler support.
- (4) Connect the front exhaust pipe to the rear exhaust pipe with the new gasket and new nuts.
- (5) Tighten the attaching nuts to the specified torque.  
Tightening Torque: 15.7 - 22.6 N-m  
(1.6 - 2.3 kgf-m, 11.6 - 16.6 ft-lb)

G2LU00044-00000

- (6) Install the lower arm bracket connecting rod.  
Tightening Torque: 39.2 - 92.2 N-m  
(4.0 - 9.4 kgf-m, 28.9 - 68.0 ft-lb)

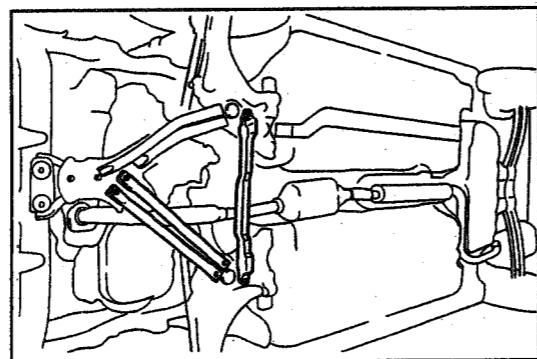

G2LU00045-99999

- (7) Install the engine lower mounting No. 2 member.  
Tightening Torque:  
M10: 48.1 - 89.2 N-m  
(4.9 - 9.1 kgf-m, 35.4 - 65.8 ft-lb)  
M12: 29.4 - 44.1 N-m  
(3.0 - 4.5 kgf-m, 21.7 - 32.5 ft-lb)

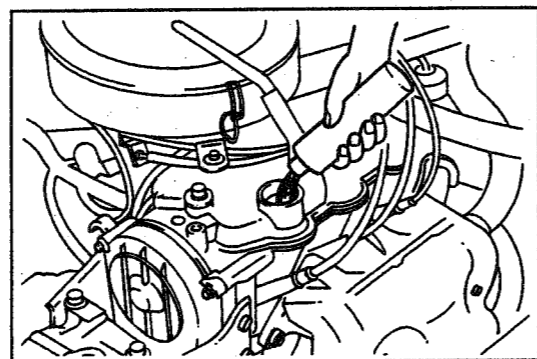

G2LU00046-99999

9. Install the engine right side under cover.
10. Jack down the vehicle.
11. Fill engine oil  
(See page LU-4.)
12. Connect the battery ground cable to the negative (-) terminal of the battery.
13. Start the engine and warm up it. Check the engine for oil leakage.  
If necessary, repair oil leakage.

G2LU00047-00000

APPENDIX

SSTs

Illustration	Tool No.	Tool name
	09990-87702-000	Engine oil pressure gauge
	09228-87201-000	Oil filter wrench (Removal and installation of oil filter)

G2LU00048-99999

TIGHTENING TORQUE

Tightening component	Tightening torque		
	N-m	kgf-m	ft-lb
Cylinder block x Oil filter bracket	14.7 - 21.6	1.5 - 2.2	10.8 - 15.9
Cylinder block x Oil pressure switch	11.8 - 19.6	1.2 - 2.0	8.7 - 14.5
Oil pan x Cylinder block	3.9 - 6.9	0.4 - 0.7	2.9 - 5.1
Oil pan x Drain plug	19.6 - 29.4	2.0 - 3.0	14.5 - 21.7
Oil pump body x Oil pump cover	3.9 - 6.9	0.4 - 0.7	2.9 - 5.1

G2LU00049-00000

SERVICE SPECIFICATION

Engine oil capacity		
When only oil is changed	Full level	2.7ℓ
	Low level	1.7ℓ
When oil and filter are changed		3.0ℓ
Oil pump	Body clearance	0.1 - 0.3 mm (0.0039 - 0.0118 inch)
	Tip clearance	0.25 mm (0.0098 inch)
	Side clearance	0.20 mm (0.0078 inch)
	Oil pressure	Idling 3000 rpm

G2LU00050-00000

TROUBLE SHOOTING

Problem	Possible causes	Remedies	Page
Oil leakage	Cylinder head, cylinder block, oil cooler or oil pump body damaged or cracked Oil seal faulty Gasket faulty	Repair, if necessary. Replace oil seal. Replace gasket.	EM Section EM Section EM Section
Low oil pressure	Oil leakage Oil pump faulty Poor quality engine oil Crankshaft bearing faulty Connecting rod bearing faulty Oil filter clogged	Repair, as necessary. Repair oil pump. Change engine oil. Replace bearing. Replace bearing. Replace bearing. Repair oil filter	LU-5 LU-5 EM Section EM Section LU- 3

G2LU00051-00000