

DAIHATSU

G202

CB-Engine

FU

FUEL SYSTEM

PRECAUTIONS	FU -2
IN-VEHICLE INSPECTION	FU -2
CARBURETOR	FU -7
FUEL PUMP	FU-36
FUEL FILTER	FU-41
SST (Special Service Tools)	FU-42
SPECIFICATIONS	FU-42
TROUBLE SHOOTING	FU-43

G2FU00001-00000

PRECAUTIONS

1. Before working on the fuel system, be sure to disconnect the ground cable from the negative (-) terminal of the battery.
2. When working on the fuel system, never allow any naked fire to be brought near the working site. Also, never smoke cigarette or the like.
3. Do not allow the fuel to get to any parts made of rubber or resin.
4. Do not work on the fuel system of more than one vehicle at the same time.
5. Be certain to keep each part of the fuel system from contamination.
6. Be very careful not to allow any dirt or the like be mixed into the fuel system during the servicing operation.
7. Make sure to keep the working site clean. Also, be sure not to lose any part, specifically small parts.
8. Never lose nor mix up those pins, clips and springs with each other.

G2FU00002-00000

IN-VEHICLE INSPECTION

NOTE:

- Before starting the engine, plug the ITC valve hoses and disconnected hoses, etc. to prevent rough idling.

1. Removal of air cleaner

- (1) Remove the resistive cords.
- (2) Disconnect the hoses and duct from the air cleaner.
- (3) Detach the cool air inlet from the clamps.
- (4) Remove the bolt and nut.
- (5) Remove the air cleaner case.

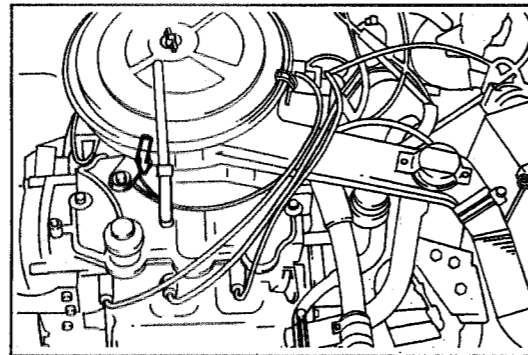

G2FU00003-99999

2. Inspection of carburetor and linkage

- (1) Ensure that each screw plug is installed correctly.
- (2) Check each linkage for evidence of excessive wear. Also, check to see if any snap ring is missing.
- (3) With the acceleration pedal fully depressed, check to see if the throttle valve opens fully.

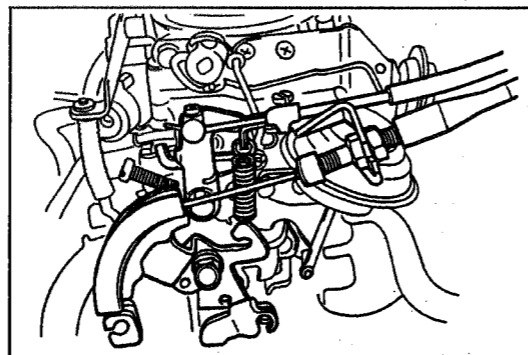

G2FU00004-99999

3. Inspection of choke system

- (1) With the choke knob pulled out fully, depress the accelerator pedal once fully. Under this condition, check to see if the choke valve is closed completely.

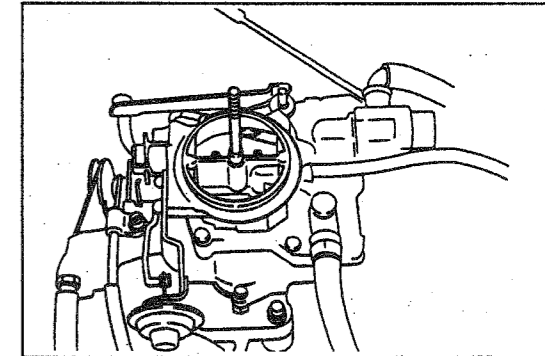

G2FU00005-99999

- (2) Attach a MityVac to the choke opener. Apply a negative pressure (at least 300 mmHg). Check to see if the choke valve opening is approximately 30 degrees and the cam roller disengages from the first stage of the fast idle cam.

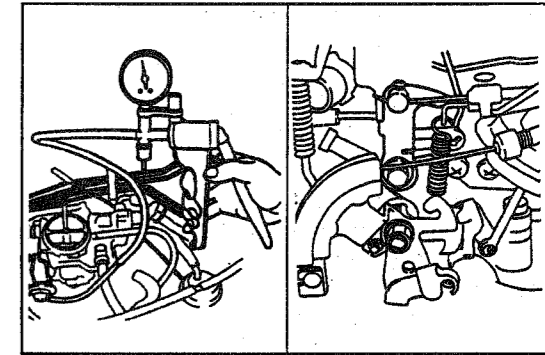

G2FU00006-99999

- (3) Remove the MityVac. Connect the rubber hose to the choke opener.

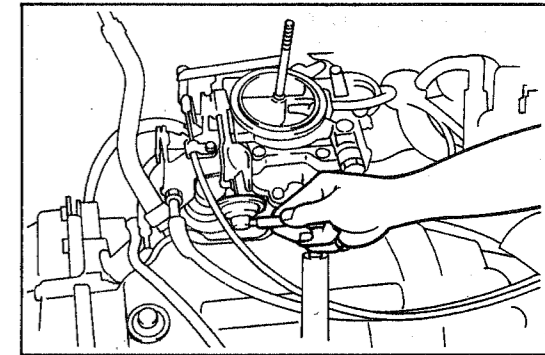

G2FU00007-99999

- (4) Return the choke knob fully. Check to see if the choke valve opens completely.

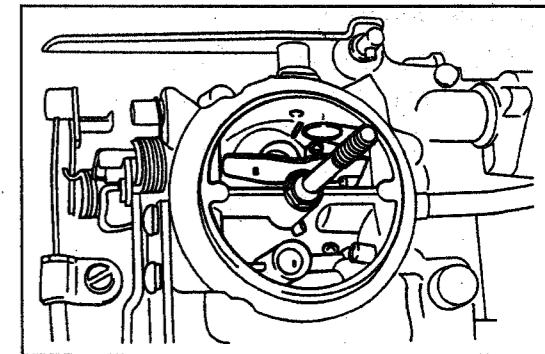

G2FU00008-99999

4. Inspection of acceleration pump

Check to see if the fuel squirts out from the acceleration nozzle when the throttle valve is opened quickly.

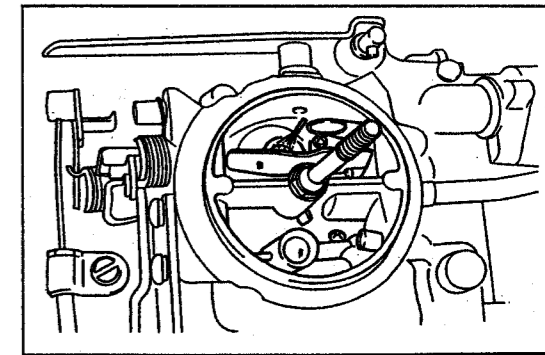

G2FU00009-99999

5. Inspection of solenoid valve

- (1) Check to see if you can feel the operation of the solenoid valve when the ignition switch is turned ON/OFF. If the solenoid valve remains inoperative, check the power supply for the solenoid valve. Then, proceed to the check described in the step (2) below.

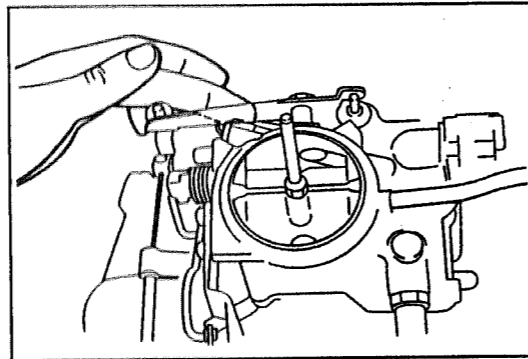

G2FU00010-99999

- (2) Disconnect the connector from the carburetor. Check to see if the resistance between the solenoid valve terminal and the carburetor proper conforms to the specification.

Specified Resistance: 80 - 100Ω at 20°C (68°F)

If the resistance fails to conform to the specification, replace the solenoid valve.

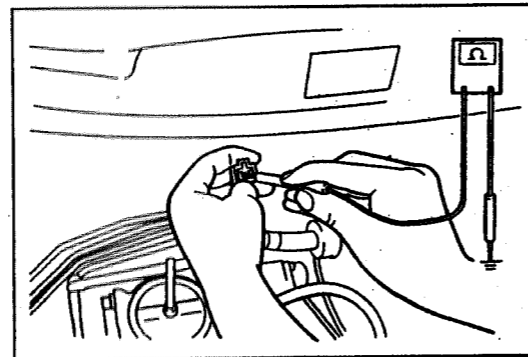

G2FU00011-99999

- (3) Reconnect the connector.

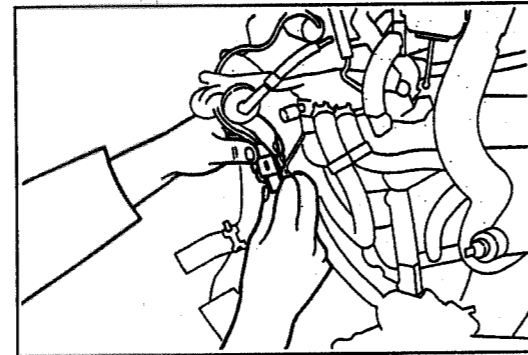

G2FU00012-99999

6. Inspection of outer vent valve

- (1) Check to see if you can feel the operation of the outer vent valve when the ignition switch is turned ON/OFF. If the outer vent valve remains inoperative, check the power supply for the outer vent valve. Then, proceed to the check described in the step (2) below.

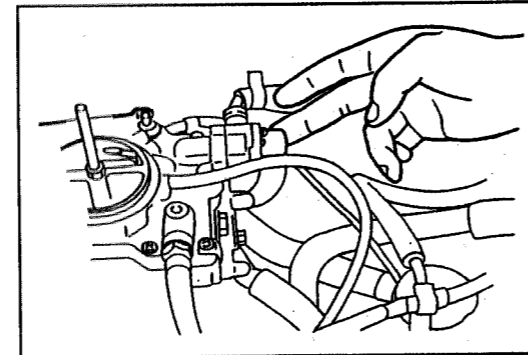

G2FU00013-99999

- (2) Disconnect the connector of the outer vent valve from the carburetor. Check to see if the resistance between the outer vent valve terminal and the carburetor proper conforms to the specification.

Specified Resistance: 30 - 40Ω at 20°C (68°F)

If the resistance fails to conform to the specification, replace the outer vent valve.

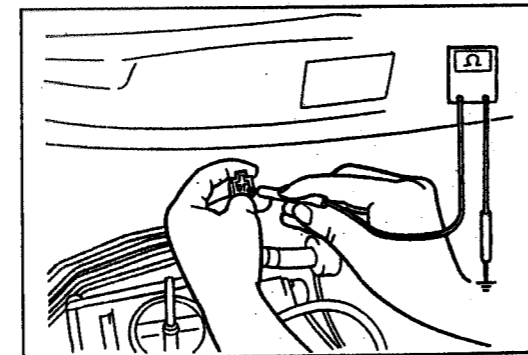

G2FU00014-99999

- (3) Reconnect the outer vent valve connector.
 (4) Disconnect the outer vent hose from the BVSV. Turn ON the ignition key switch.

G2FU00015-00000

- (5) Blow air from the outer vent hose. Ensure that no air continuity exists. If air continuity exists, replace the outer vent valve.

WARNING:

- Be very careful not to inhale the air.

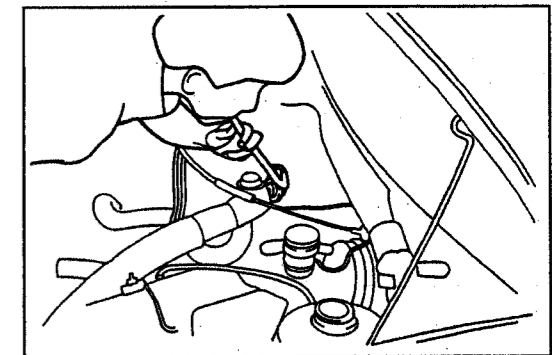

G2FU00016-99999

- (6) Turn OFF the ignition key switch.
 (7) Blow air from the outer vent hose. Ensure that air continuity exists. If no air continuity exists, replace the outer vent valve.

WARNING:

- Be very careful not to inhale the air.

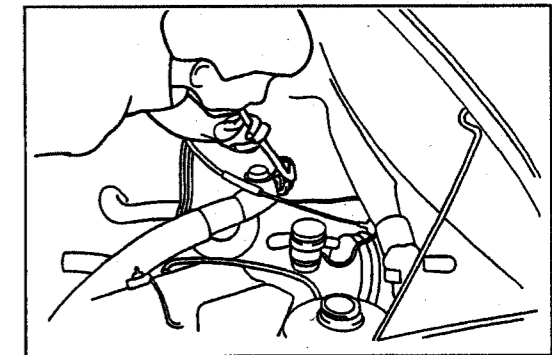

G2FU00017-99999

- (8) Connect the outer vent hose to the BVSV.

7. Inspection of vacuum motor

- (1) Disconnect the air duct from the air cleaner case by removing the hose band.
 (2) Disconnect the vacuum hose from the vacuum motor.
 (3) Connect a MityVac to the vacuum motor.
 (4) Ensure that the vacuum motor operates properly when a negative pressure of -53.3 kPa (-400 mmHg, -157.5 inHg) is applied. If not, replace the air cleaner case.
 (5) Connect the vacuum hose to the vacuum motor.
 (6) Connect the air duct to the air cleaner case.
 (7) Attach the hose band temporarily.

NOTE:

- Secure the hose band after the installation of the air cleaner.

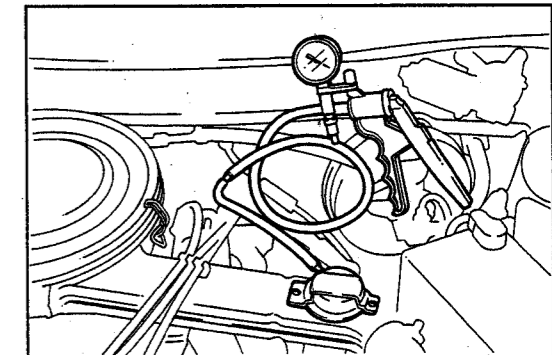

G2FU00018-99999

8. Installation of air cleaner

- (1) Ensure that no damage is present on the air cleaner case gasket.
If damage is present, replace the gasket with a new one.
- (2) Place the air cleaner lower case on the carburetor.
- (3) Install the attaching bolt of the air cleaner lower case to the cylinder head.
- (4) Connect the hoses and ducts to the air cleaner case.

- (5) Place the air cleaner element on the air cleaner lower case while aligning the protrusions of the air cleaner element and air cleaner lower case.
- (6) Connect the cool air inlet to the clamps.
- (7) Place the air cleaner upper case on the air cleaner lower case while aligning the protrusions of the air cleaner upper case and air cleaner lower case with each other.
- (8) Secure the air cleaner upper case with the wing nut and clips.
- (9) Connect and secure the hot air intake duct to the air cleaner case (Except for tropical specification).
- (10) Connect the resistive cord.

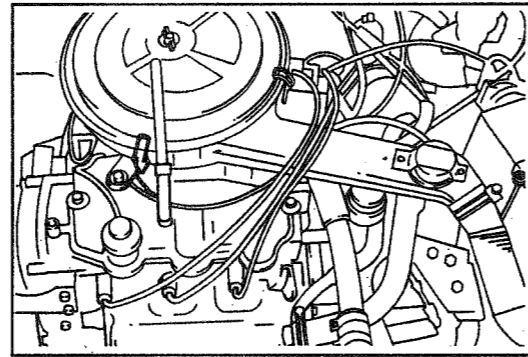
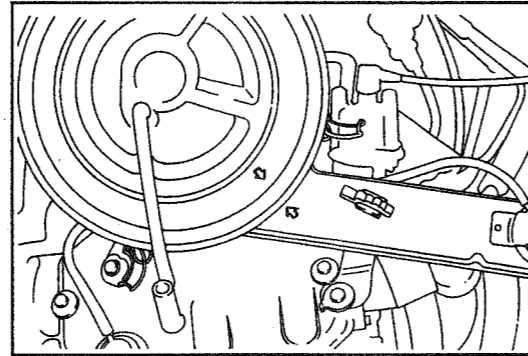

9. Inspection of choke opener

(Refer to the MA section of the service manual.)

10. Inspection of fast idle

(Refer to the MA section of the service manual.)

11. Inspection of throttle positioner

(Refer to the MA section of the service manual.)

**CARBURETOR
SCHEMATIC DIAGRAM**

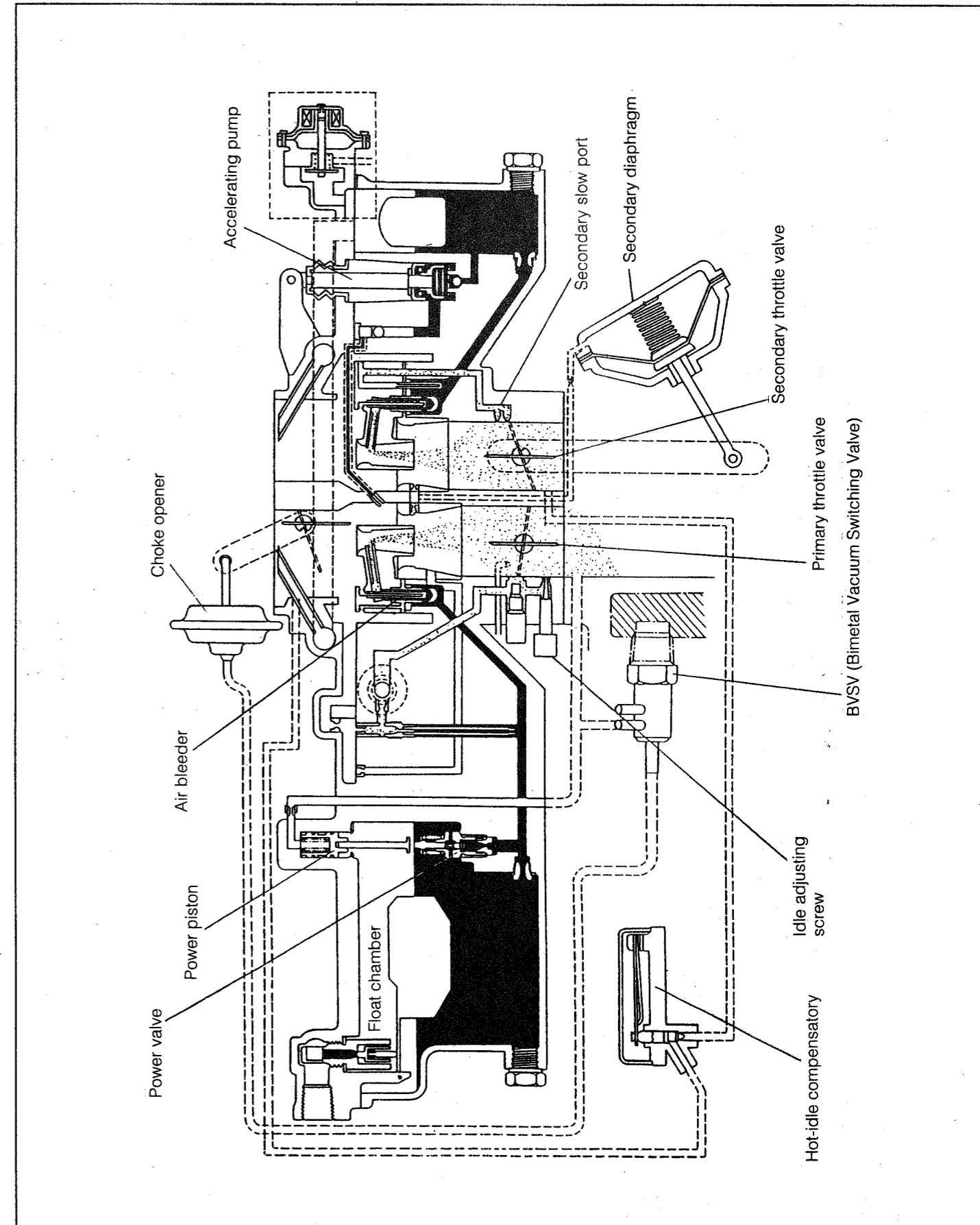

COMPONENTS

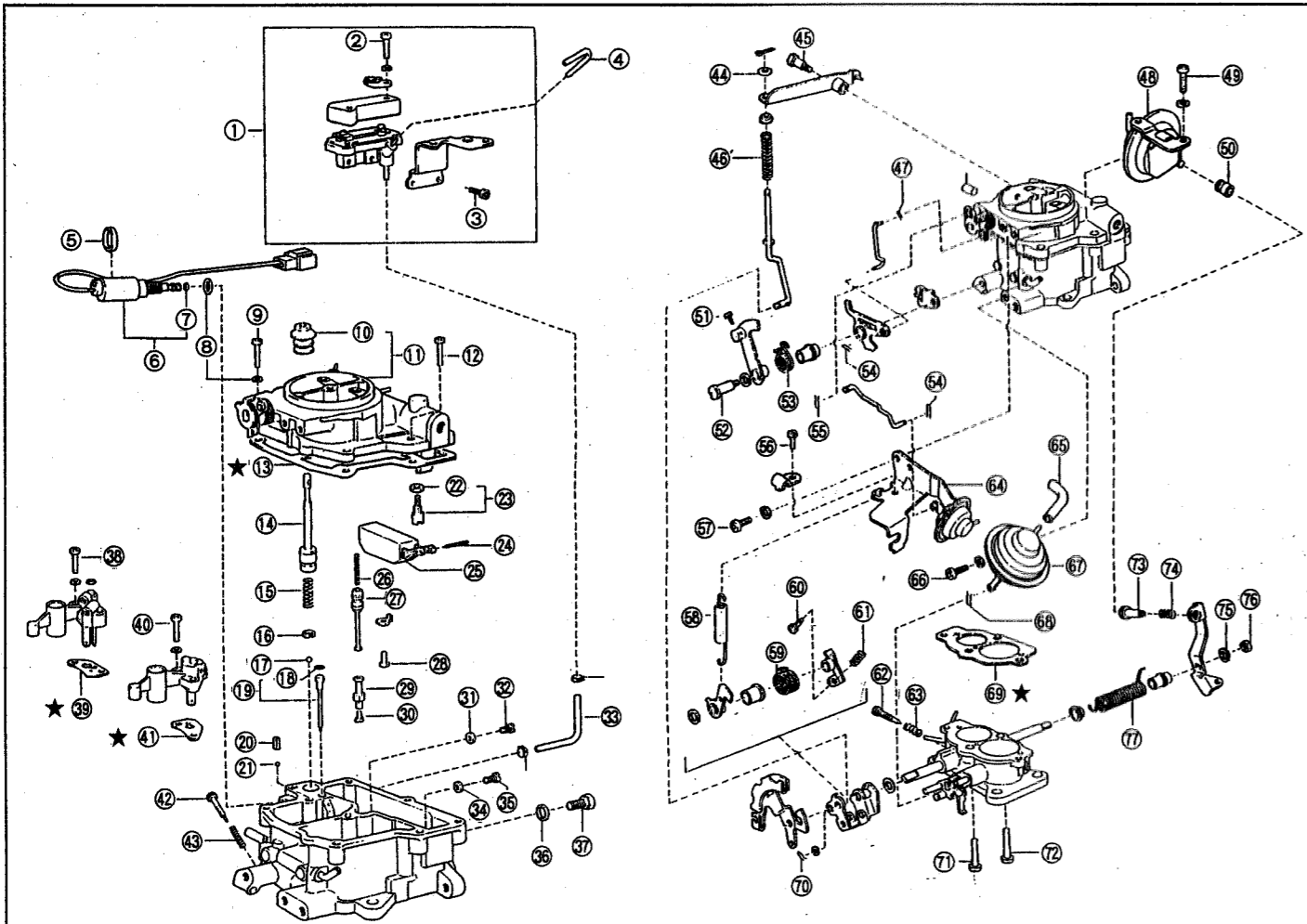

★ : Non-reusable parts

- ① Thermostatic valve
- ②, ③, ⑨, ⑫, ⑳, ⑳ Screw
- ④, ⑬ Pipe
- ⑤ Support
- ⑥ Throttle valve solenoid
- ⑦, ⑱ O-ring
- ⑧ Solenoid valve gasket
- ⑩ Boot
- ⑪ Air horn
- ⑬ Air horn gasket
- ⑭ Pump plunger
- ⑮ Pump diaphragm spring
- ⑯ Check ball retainer
- ⑰, ⑳ Steel ball
- ⑱ Slow jet
- ⑳ Pump discharge weight
- ㉑ Needle valve seat gasket
- ㉒ Needle valve
- ㉓ Float lever pin
- ㉔ Float
- ㉕ Power piston spring
- ㉖ Power piston
- Power piston stop screw
- ㉘ Power valve
- ㉙ Power jet
- ㉚, ㉛ Main jet gasket
- ㉜ Primary jet
- ㉝ Secondary jet
- ㉞ Main passage plug gasket

- ㉟ Main passage plug
- ㊱, ㊲ Venturi gasket
- ㊳ Throttle adjusting screw
- ㊴ Throttle adjusting spring
- ㊵ Plunger inner washer
- ㊶ Pump arm set screw
- ㊷ Pump arm spring
- ㊸, ㊹, ㊺, ㊻, ㊼ Snap ring
- ㊽ Positioner
- ㊾, ㊿, ① Screw
- ② Boot
- ③ Fast idle cam set screw
- ④, ⑤, ⑥ Back spring
- ⑦ Choke wire clamp screw
- ⑧ Throttle return spring
- ⑨, ⑩, ⑪ Set screw
- ⑫ Fast idle cam spring
- ⑬ Idle adjusting screw
- ⑭ Idle adjusting spring
- ⑮ Choke opener
- ⑯ Vacuum hose
- ⑰ Diaphragm housing set screw
- ⑱ Diaphragm
- ⑲ Body flange gasket
- ㉓ Adjusting screw
- ㉔ Adjusting screw spring
- ㉕ Lock washer
- ㉖ Throttle lever set nut

REMOVAL OF CARBURETOR

1. Disconnect the ground cable terminal from the negative (-) terminal of the battery.
2. Drain the coolant. (See page CO-3.)

3. Removal of air cleaner
 - (1) Disconnect the resistive cord.
 - (2) Remove the rubber hoses and ducts.
 - (3) Remove the air cleaner. (See page FU-2.)

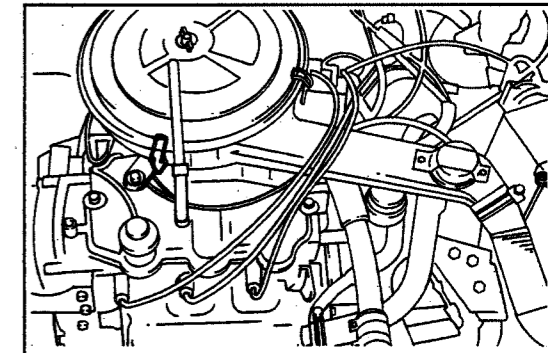

4. Disconnect the accelerator cable from the carburetor.
5. Disconnect the choke cable from the carburetor.

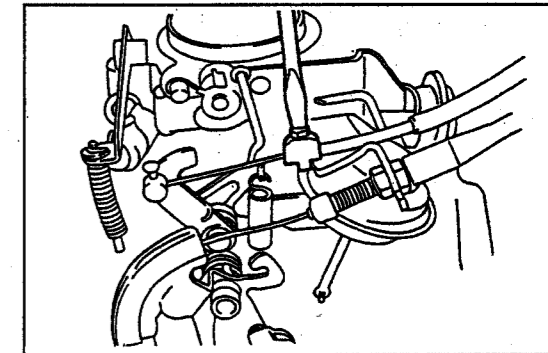

6. Remove the fuel hoses and vacuum hoses from the carburetor.

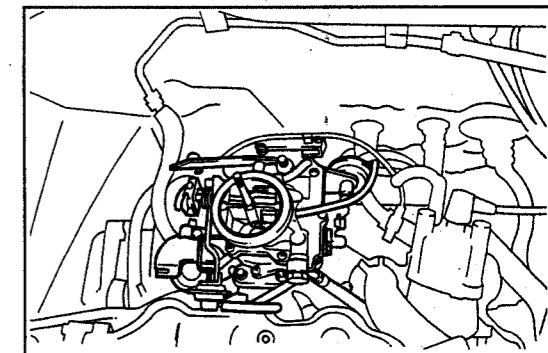

7. Disconnect the solenoid valve outer vent valve connector.
8. Remove the four attaching nuts of the carburetor. Remove the carburetor.

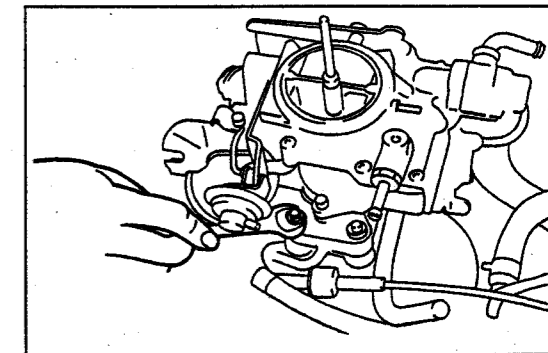

DISASSEMBLY OF CARBURETOR

NOTE:

- The following operations have been arranged in such a way that checks are performed for a certain single unit alone at a time. This will avoid any occurrence of wrong assembling of similar subassemblies which would likely occur when operations are carried out concurrently.

- (1) Be sure to arrange the disassembled parts in order so that reassembling may be performed readily.
- (2) Do not mix up those balls, clips, springs and so forth.
- (3) Be sure to employ the following SST, a set of screwdrivers for carburetor use.
SST: 09860-11011-000

G2FU00028-00000

DISASSEMBLY OF AIR HORN

1. Remove the air cleaner set bolt.
2. Removal of air horn assembly
 - (1) Disconnect the accelerator pump arm from the air horn by removing the set bolt of the accelerator pump arm.

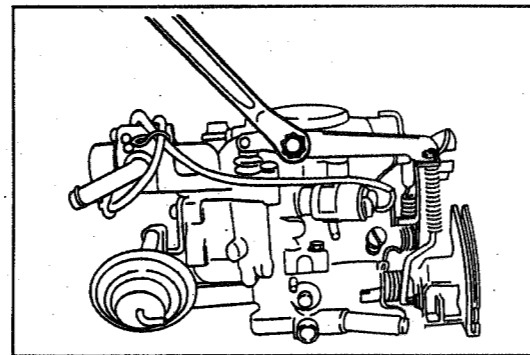

G2FU00029-99999

- (2) Remove the accelerator pump rod from the throttle idle adjusting lever by removing the snap ring.

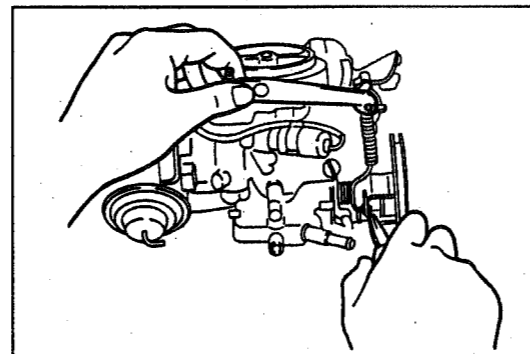

G2FU00030-99999

- (3) Remove the choke opener link by removing the snap rings and washers.

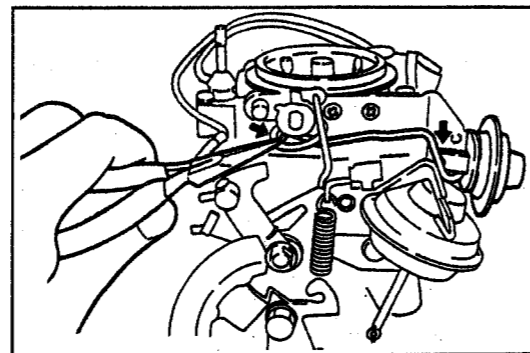

G2FU00031-99999

- (4) Disconnect the fast idle cam link by removing the snap ring.

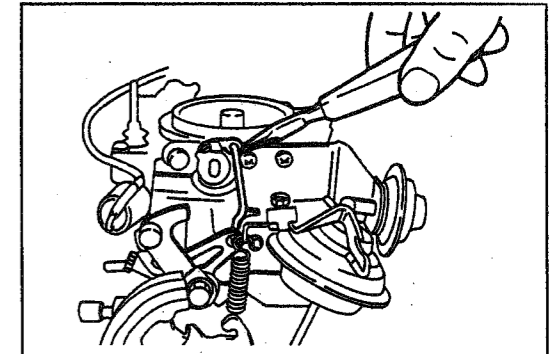

G2FU00032-99999

- (5) Detach the throttle return spring.

NOTE:

- Be very careful not to scratch the spring.

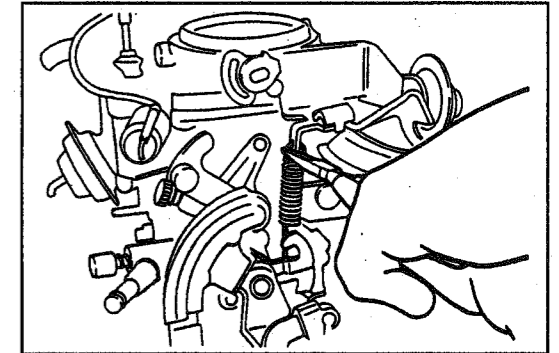

G2FU00033-99999

- (6) Remove the choke opener by removing the attaching screws.

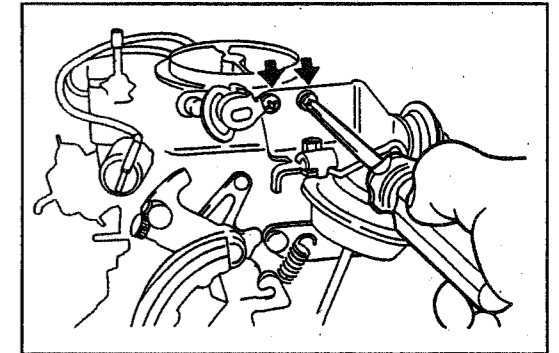

G2FU00034-99999

- (7) Disconnect the outer vent valve connector from the connector and the socket.

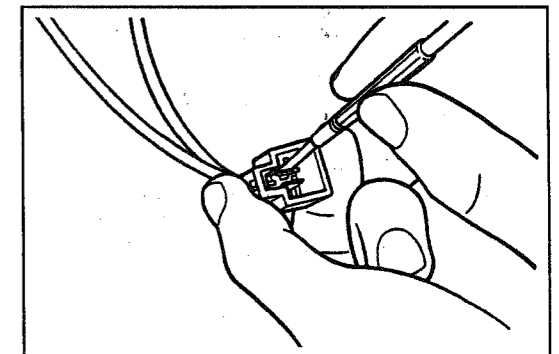

G2FU00035-99999

- (8) Remove the outer vent valve and the gasket by removing the three attaching screws.

NOTE:

- Do not reuse the gasket.

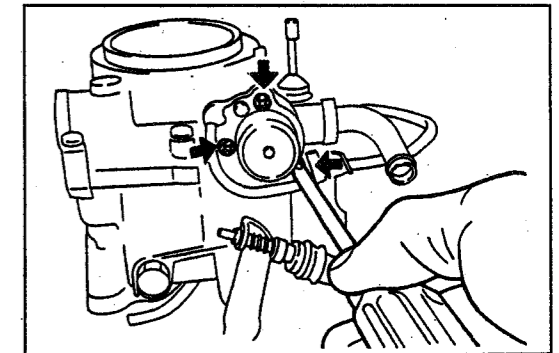

G2FU00036-99999

(9) Remove the thermostatic valve.

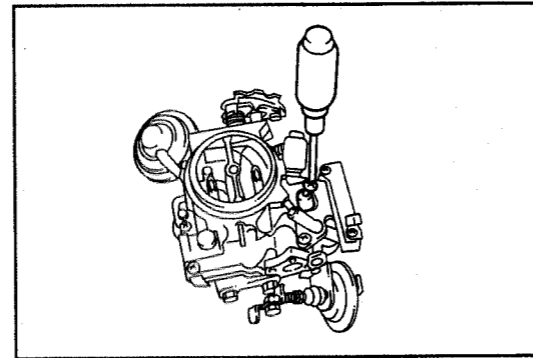

G2FU00037-99999

(10) Remove the attaching screws of the air horn.
 (11) Remove the air horn.

CAUTION:

- Be very careful not to lose the discharge weight, springs and ball.

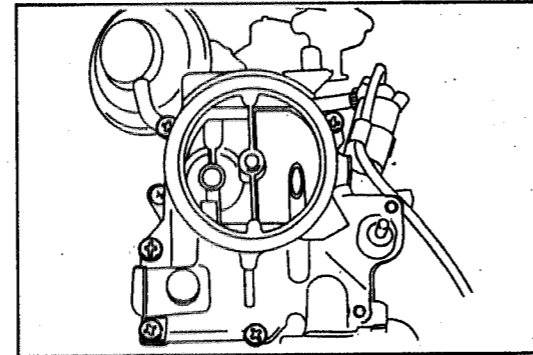

G2FU00038-99999

(12) Remove the float by removing the float lever pin.

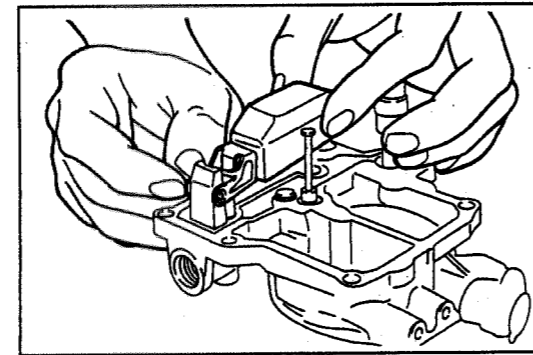

G2FU00039-99999

(13) Remove the needle valve and the gasket from the air horn.

NOTE:

- Do not reuse the gasket.

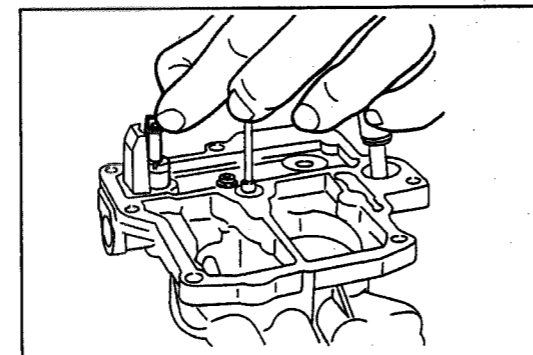

G2FU00040-99999

(14) Remove the power piston by removing the attaching bolt of the retainer of the power piston.

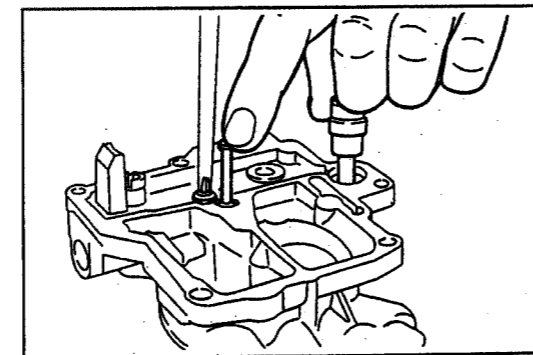

G2FU00041-99999

(15) Remove the acceleration pump piston.
 (16) Remove the boot of the acceleration pump piston.

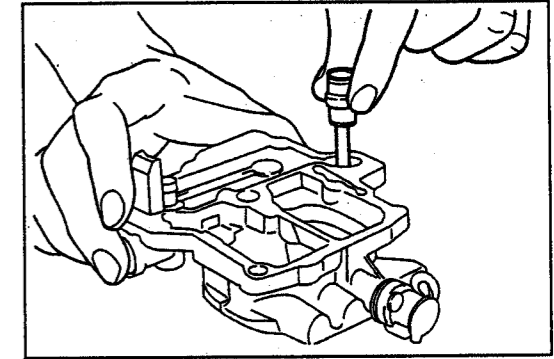

G2FU00042-99999

(17) Remove the needle valve seat and washer.

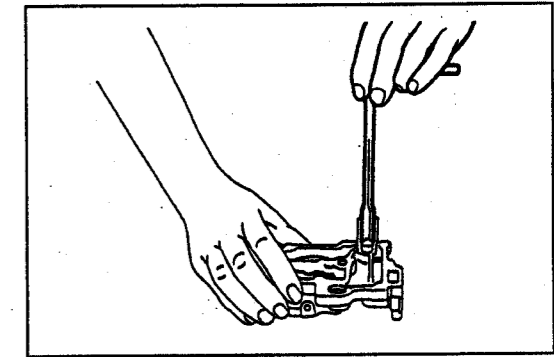

G2FU00043-99999

DISASSEMBLY OF CARBURETOR BODY

1. Remove the solenoid valve and the gasket.

CAUTION:

- Do not twist the solenoid valve wire.

NOTE:

- Do not reuse the gasket.

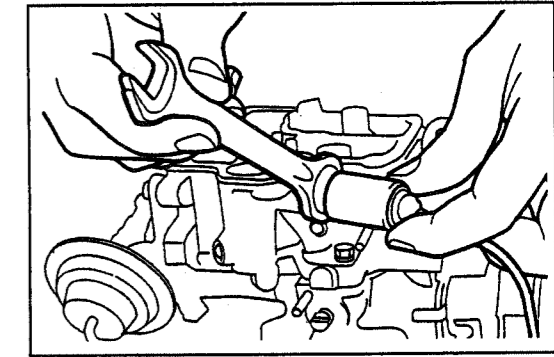

G2FU00044-99999

2. Remove the gasket.

NOTE:

- Do not reuse the gasket.

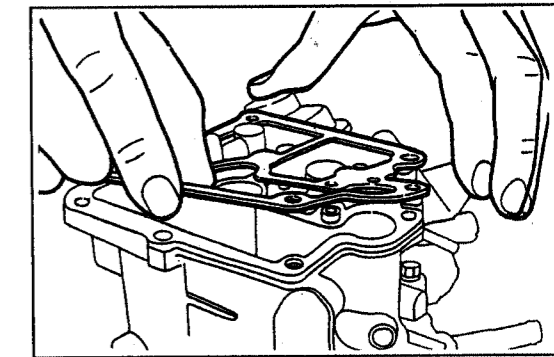

G2FU00045-99999

3. Remove the discharge weight, spring and ball.

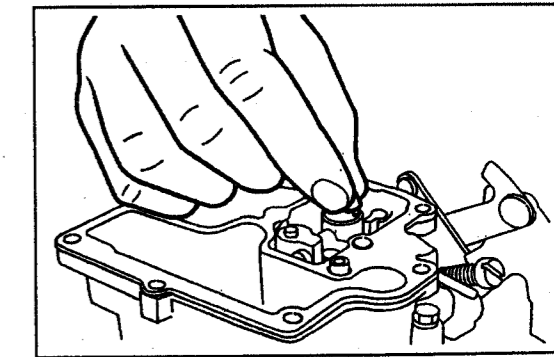

G2FU00046-99999

4. Remove the acceleration pump return spring.

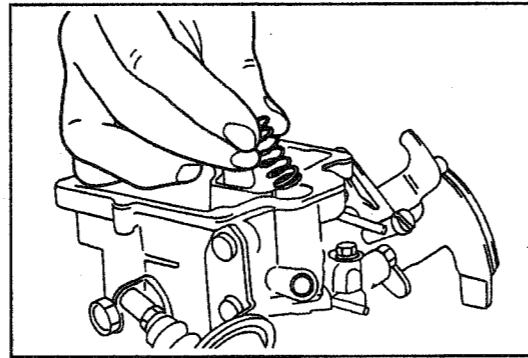

G2FU00047-99999

5. Removal of throttle positioner
(1) Remove the throttle lever set nut.

CAUTION:

- Be sure to hold the other end of the throttle shaft or lever with a vice or suitable tools to prevent excessive force from applying to the throttle valve.

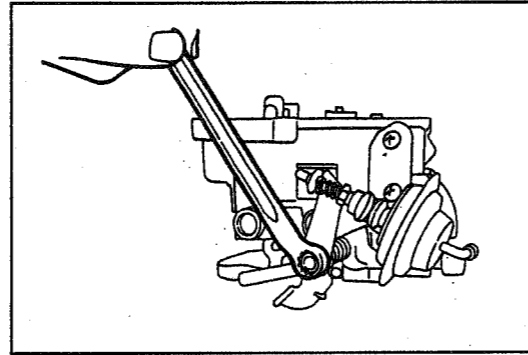

G2FU00048-99999

(2) Remove the throttle positioner lever.
(3) Remove the collars and spring.

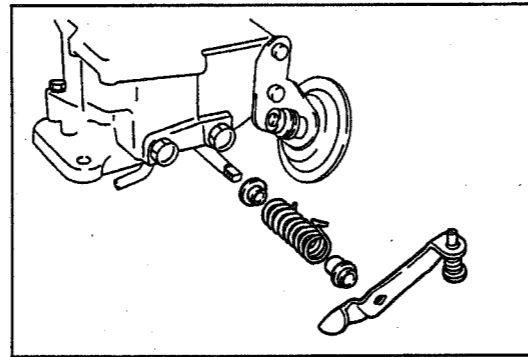

G2FU00049-99999

(4) Remove the throttle positioner by removing the two attaching screws.

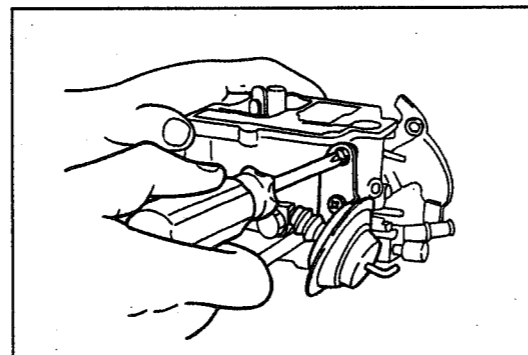

G2FU00050-99999

6. Removal of secondary throttle valve diaphragm

- (1) Remove the snap ring.
- (2) Remove the thrust washer.
- (3) Disconnect the link.

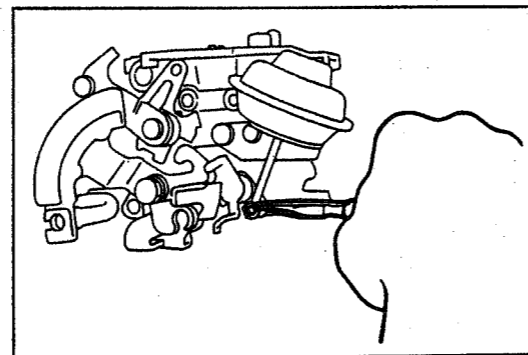

G2FU00051-99999

(4) Remove the secondary throttle diaphragm by removing the two attaching screws.

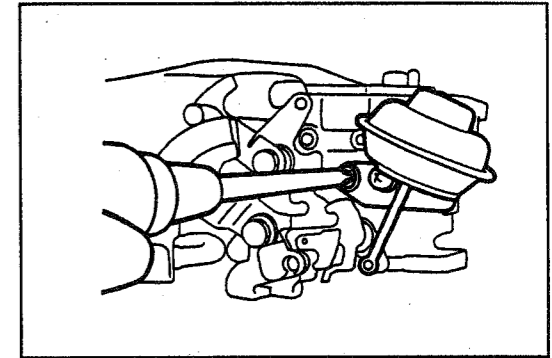

G2FU00052-99999

(5) Remove the secondary throttle diaphragm rubber hose from the carburetor body.

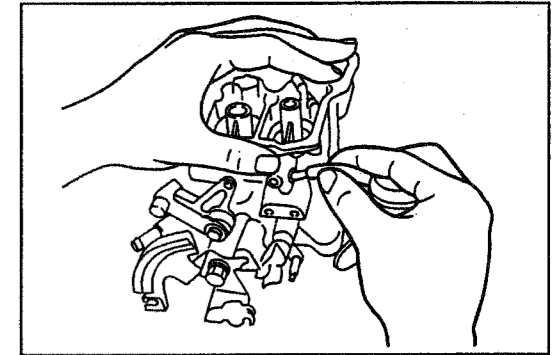

G2FU00053-99999

7. Removal of fast idle cam set screw

(1) Detach the throttle return spring from the fast idle cam.

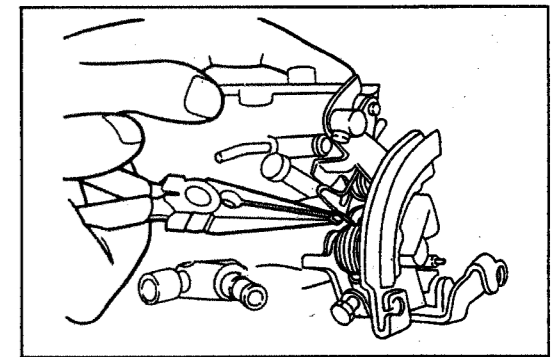

G2FU00054-99999

(2) Remove the fast idle cam set screw together with the fast idle cam lever spring and choke lever return spring bracket.

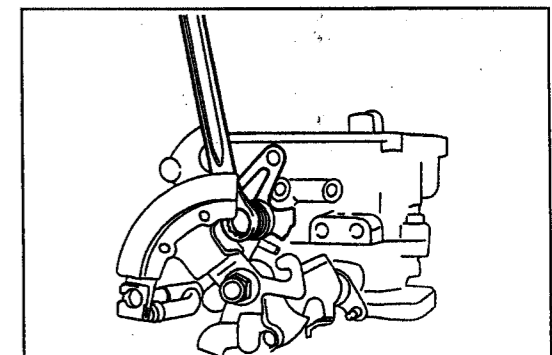

G2FU00055-99999

8. Remove the throttle lever, kick-up lever, fast idle adjusting lever, spring and collar.

CAUTION:

- Be sure to hold the other end of the throttle shaft with a vice or suitable tools to prevent excessive force from applying to the throttle valve.

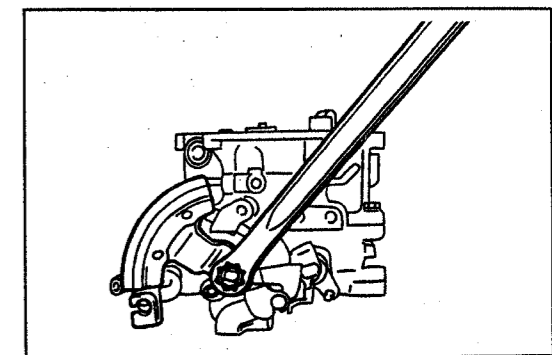

G2FU00056-99999

9. Remove the slow jet.

NOTE:

- Do not reuse the O-ring.

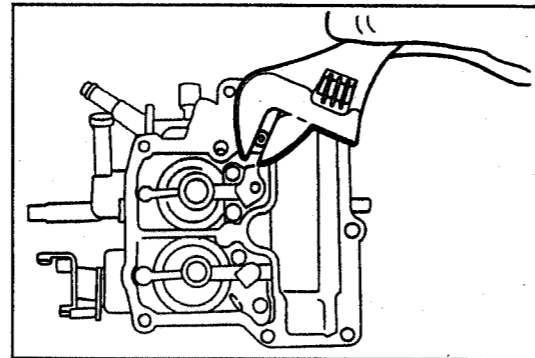

G2FU00057-99999

10. Remove the primary and secondary small venturi tubes and gaskets.

NOTE:

- Do not reuse the gaskets.

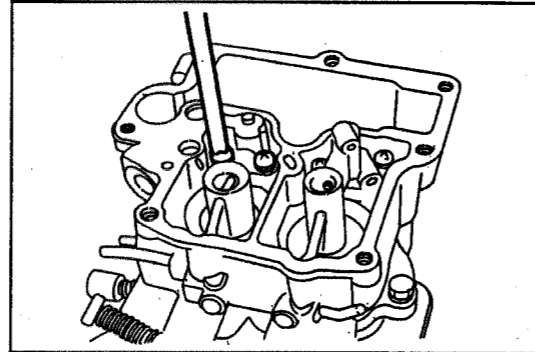

G2FU00058-99999

11. Remove the main passage plugs and the gasket.

12. Remove the primary and secondary main jets with the gaskets.

NOTE:

- Do not reuse the gaskets.

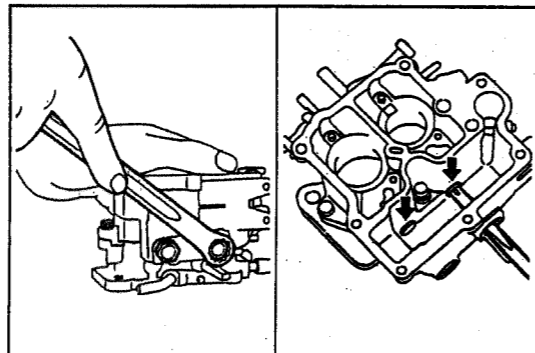

G2FU00059-99999

13. Remove the power valve, using the SST.

14. Remove the acceleration pump check ball retainer.

SST: 09860-11011-000

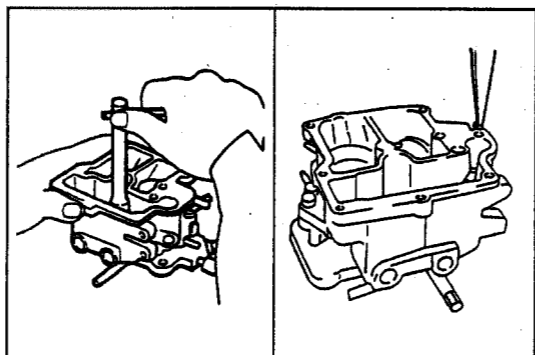

G2FU00060-99999

15. Remove the throttle adjusting screw.

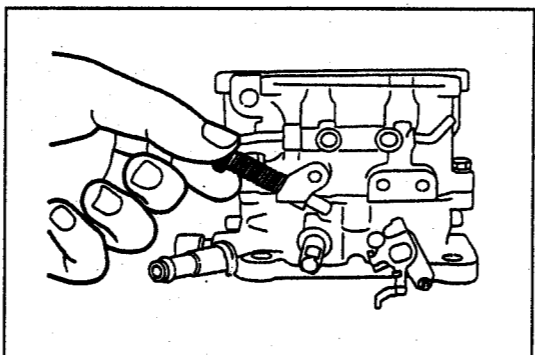

G2FU00061-99999

16. Separation of carburetor body and flange

(1) Remove the attaching bolts and nuts.

(2) Separate the carburetor body and flange.

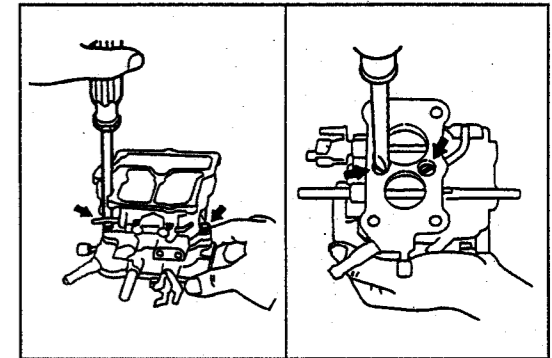

G2FU00062-99999

17. Remove the idle mixture adjusting screw, using the SST.

SST: 09243-00020-000

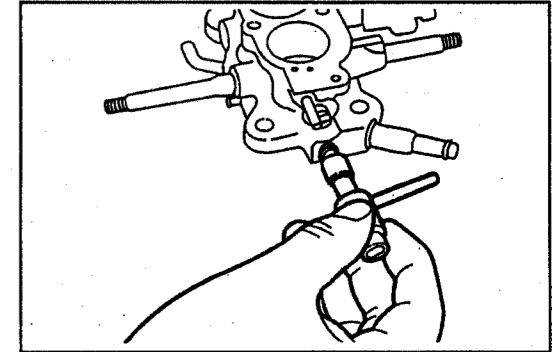

G2FU00063-99999

18. Remove the power jet from the power valve.

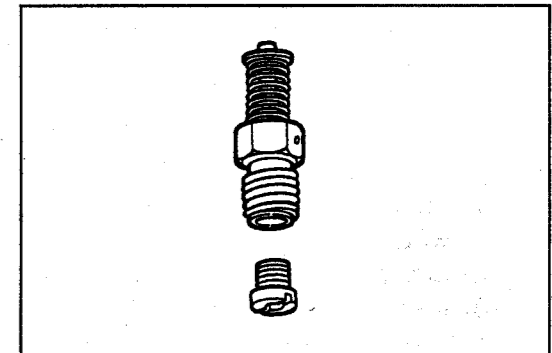

G2FU00064-99999

CLEANING OF EACH PART

1. Clean the carburetor parts except for diaphragms and electrical parts, using the carburetor cleaner and a soft brush.
2. Remove the carbon deposits by means of a soft brush.
3. Clean each of the jets and nozzles, using compressed air.

CAUTION:

- Never clean the jets or orifices with a piece of wire or a drill.
Failure to observe this caution may enlarge the openings, resulting in poor fuel mileage.

WARNING:

- Be sure to protect your eyes with safety goggles, when using compressed air.

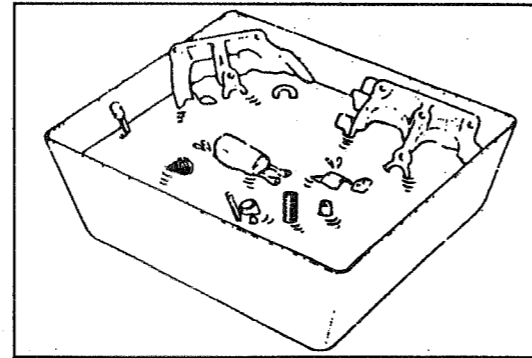

G2FU00065-99999

INSPECTION OF CARBURETOR

1. Inspection of float and needle valve

NOTE:

- If any damage is present, replace the part, as required.

- (1) Inspect the float lever pin for scratches and excessive wear.
- (2) Inspect the float for a broken lip.
- (3) Inspect the float lever pin hole of the float for wear.
- (4) Inspect the float for leakage.
- (5) Inspect the snap pin of the needle valve for damage or deformation.
- (6) Inspect the valve section of the needle valve for wear or damage.
- (7) Inspect the plunger for wear or damage.
- (8) Inspect the spring for deformation or weakness.
- (9) Inspect the strainer for breakage, restriction or damage.
- (10) Inspect the valve seat for wear or damage.

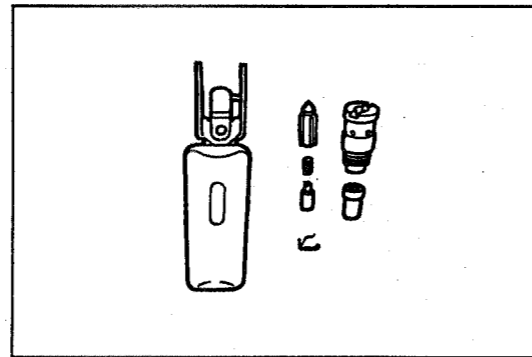

G2FU00066-99999

2. Inspection of air horn for wear or damage

NOTE:

- If any damage is present, replace the part, as required.

- (1) Check each part for cracks, wear or damage.
- (2) Check to see if each valve functions smoothly.
- (3) Check each air or fuel passage for restriction.

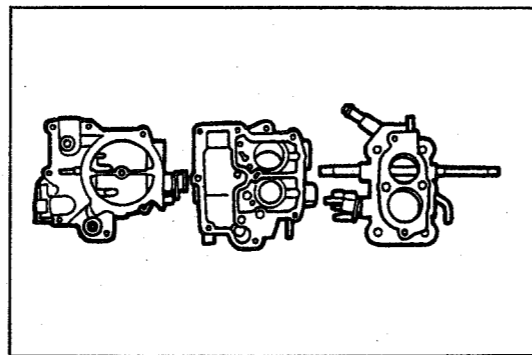

G2FU00067-99999

3. Inspection of power piston

- (1) Install the spring for power piston and the power piston.
- (2) Ensure that the power piston functions smoothly.
If any malfunction is present, replace the part, as required.

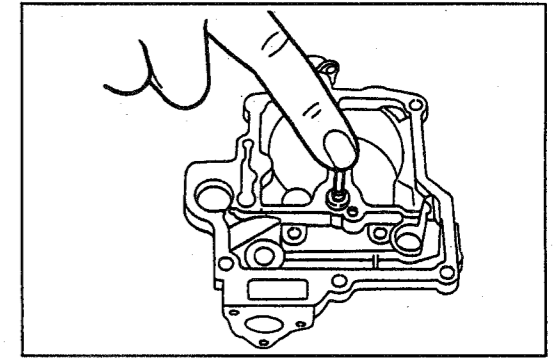

G2FU00068-99999

4. Inspection of power valve

Ensure that air continuity exists when the valve is pushed. Also, ensure that no air continuity exists when the valve is not pushed.

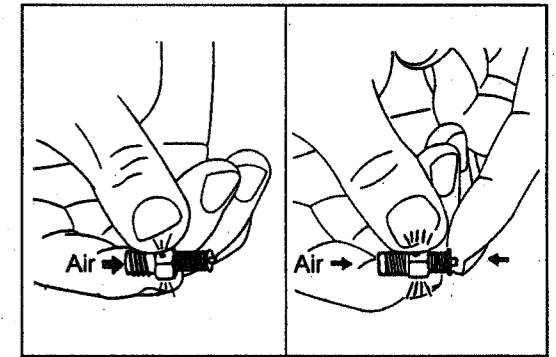

G2FU00069-99999

5. Check each jet for restriction or damage.

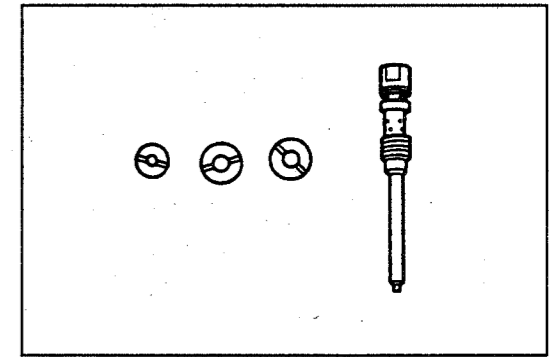

G2FU00070-99999

6. Inspection of solenoid valve

Ensure that the valve is opened when the solenoid valve is energized. Also, ensure that the valve is closed when the solenoid valve is not energized.

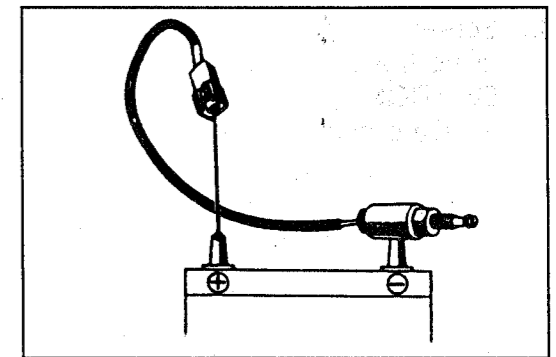

G2FU00071-99999

7. Inspection of outer vent valve

Ensure that the valve is closed when the outer vent valve is energized. Also, ensure that the valve is opened when the outer vent valve is not energized.

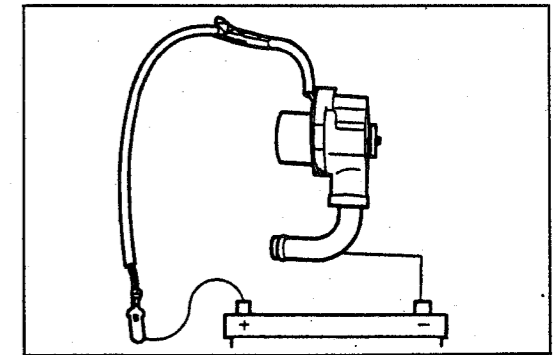

G2FU00072-99999

8. Inspection of each diaphragm
Ensure that the rod is drawn into the diaphragm chamber when a negative pressure is applied to each diaphragm. If any air leakage is present, replace the diaphragm with a new one.

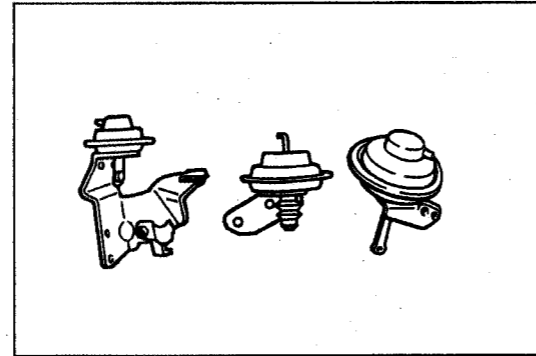

G2FU00073-99999

9. Inspection of idle mixture adjusting screw
Check to see if any damage or wear is present at the tip end of the adjusting screw. If any damage is present, replace the idle mixture adjusting screw.

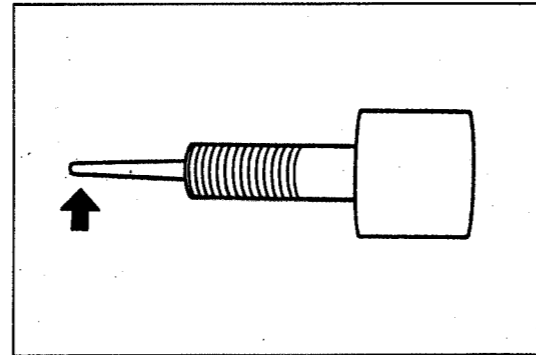

G2FU00074-99999

ASSEMBLY OF CARBURETOR

NOTE:

- Be sure to use new gaskets and O-rings.

Assembly of carburetor body & flange

1. Install the power jet in the power valve.
2. Screw in the mixture adjusting screw fully into the flange, using the SST. Then, back off the adjusting screw 4 turns.
CAUTION:
- Care must be exercised to ensure that no damage may be made to the tip-end of the adjusting screw by tightening the idle mixture adjusting screw excessively.
- SST: 09243-00020-000

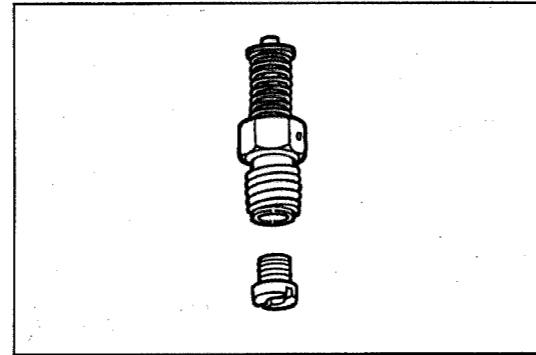

G2FU00075-99999

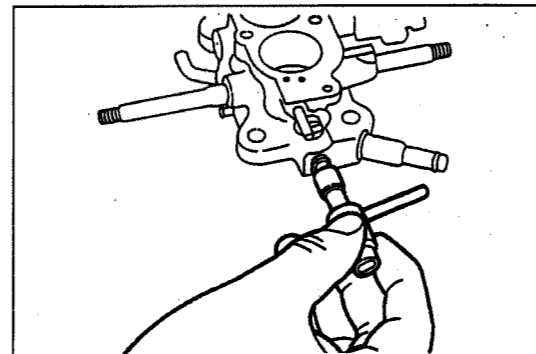

G2FU00076-99999

3. Assemble the carburetor body to the flange by means of the attaching bolts and nuts with a new gasket interposed.
NOTE:
- Be sure to use a new gasket.

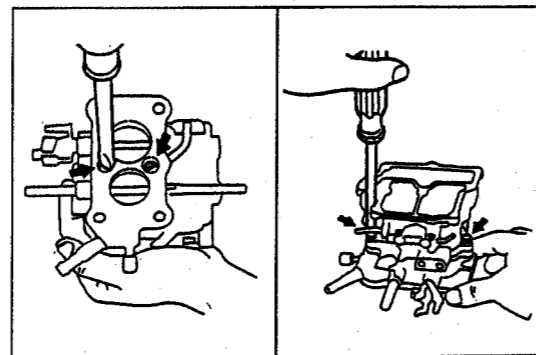

G2FU00077-99999

4. Install the throttle adjusting screw to the carburetor body.

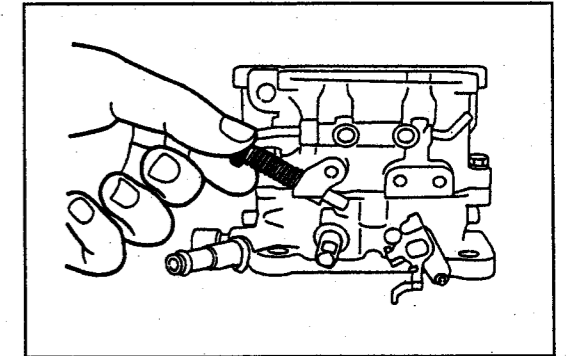

G2FU00078-99999

5. Insert the acceleration pump check ball into carburetor body.
6. Install the check ball retainer.

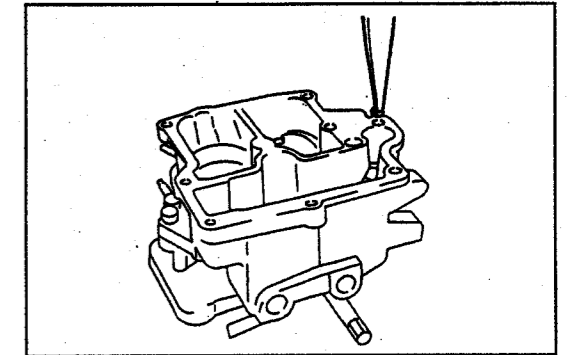

G2FU00079-99999

7. Install the power valve, using the SST.
SST: 09860-11011-000

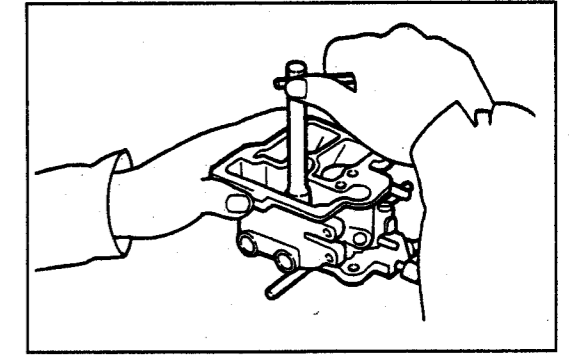

G2FU00080-99999

8. Install the primary and secondary main jets.
NOTE:
- Be sure to use a new gasket.

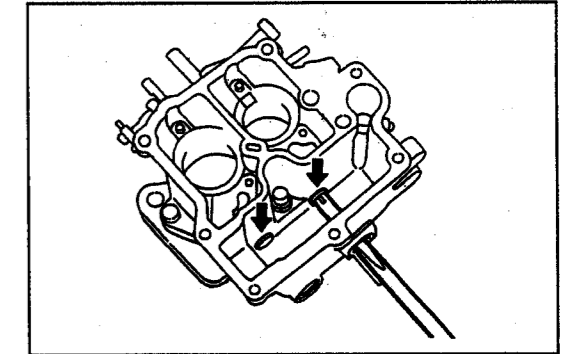

G2FU00081-99999

9. Install the main passage plugs.
NOTE:
- Be sure to use a new gasket.

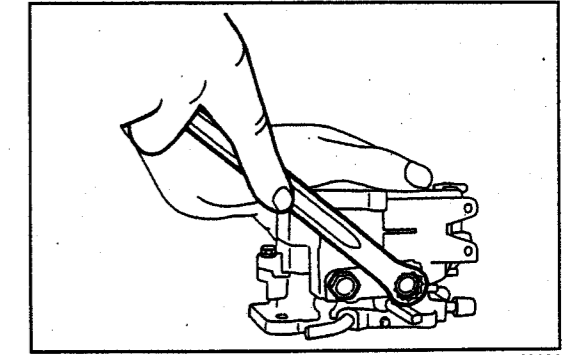

G2FU00082-99999

10. Install the primary and secondary small venturi tubes with new gaskets interposed.

NOTE:

- Be sure to use a new gasket.

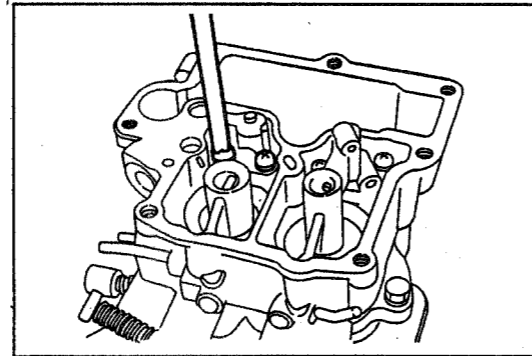

G2FU00083-99999

11. Install the slow jet.

NOTE:

- Be sure to replace the O-ring with a new one before installing the slow jet.

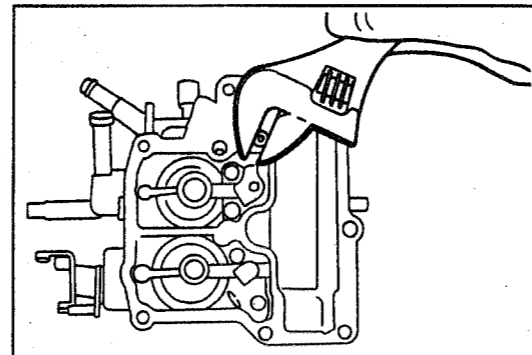

G2FU00084-99999

12. Assembly of throttle lever

(1) Insert the collar and spring onto the fast idle lever.

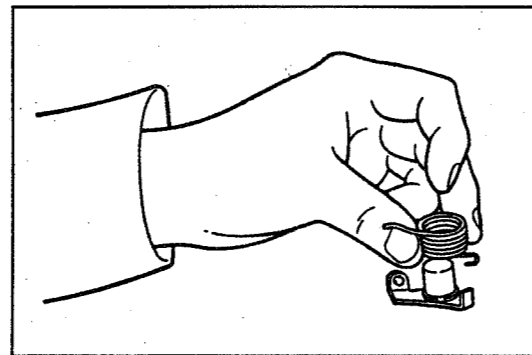

G2FU00085-99999

(2) Insert the kick-up lever onto the collar.

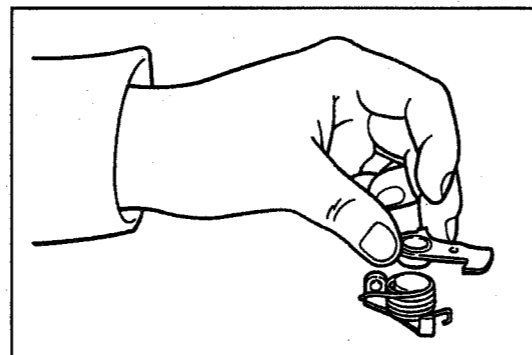

G2FU00086-99999

(3) Insert the fast idle lever, collar, spring and kick-up lever assembly onto the throttle adjusting lever.

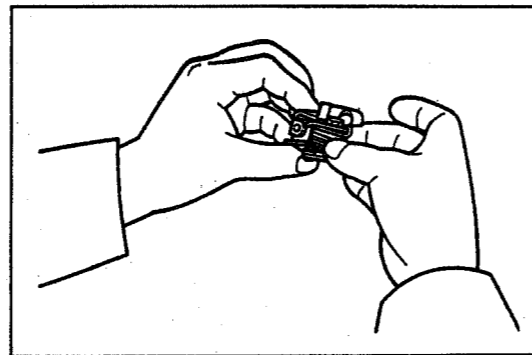

G2FU00087-99999

(4) Insert the fast idle adjusting spring onto the throttle idle adjusting lever.

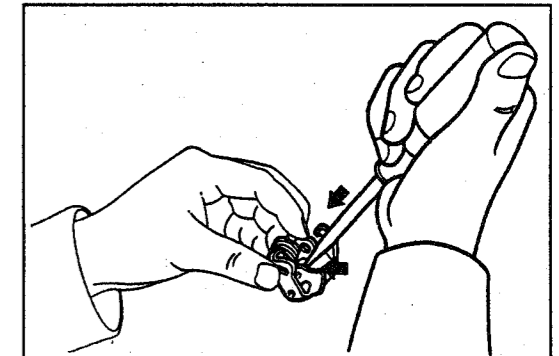

G2FU00088-99999

(5) Insert the collar into between the throttle adjusting lever and the fast idle lever.

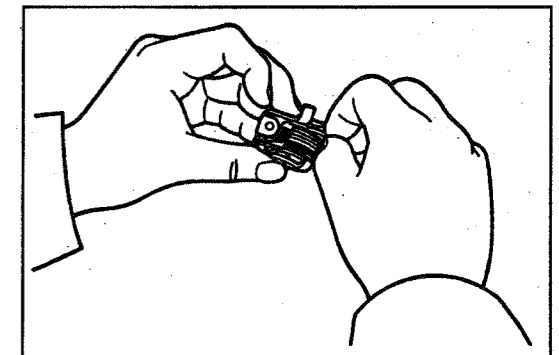

G2FU00089-99999

(6) Insert the thrust washer into the throttle shaft.

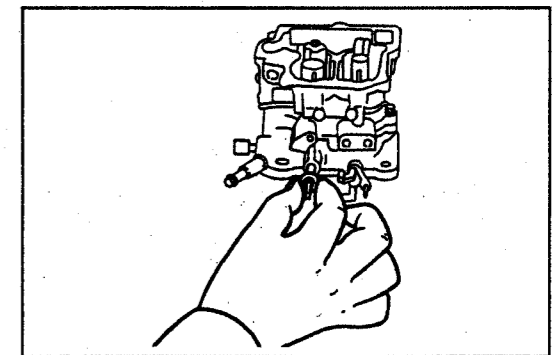

G2FU00090-99999

(7) Install the throttle adjusting lever assembly onto the throttle shaft.

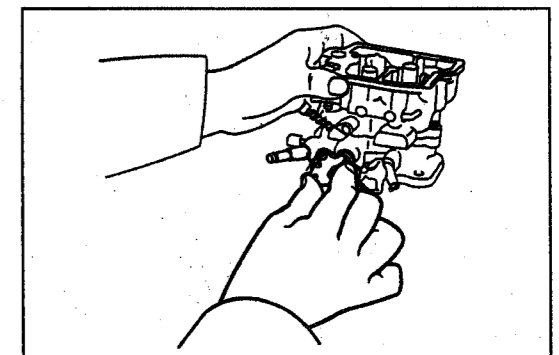

G2FU00091-99999

(8) Assemble the throttle lever while aligning the protrusion of the throttle lever with the hole of the throttle adjusting lever.

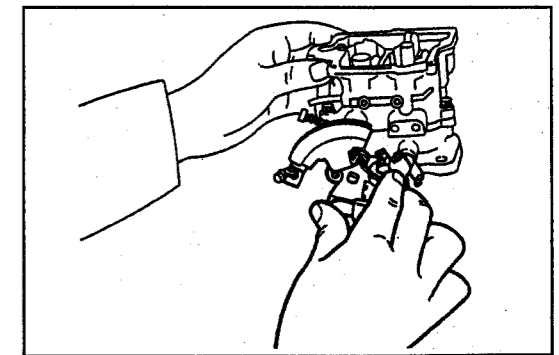

G2FU00092-99999

(9) Tighten the nut with a new washer interposed.

CAUTION:

- Be sure to prevent the throttle shaft from turning with a suitable tool during the tightening.

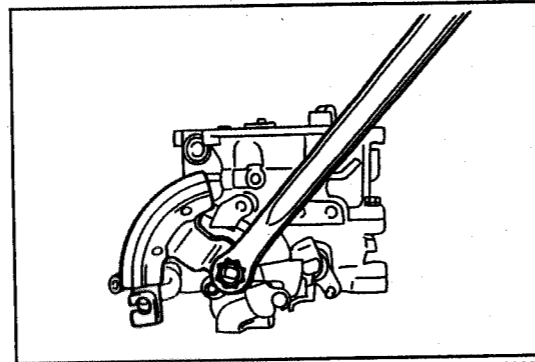

G2FU00093-99999

(10) Install the fast idle adjusting screw.

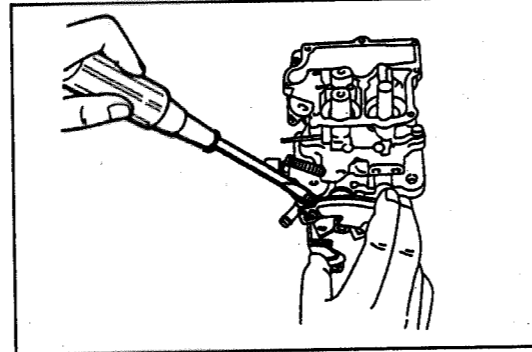

G2FU00094-99999

13. Assembly of fast idle cam set screw

(1) Install the thrust washer onto the fast idle cam set screw.

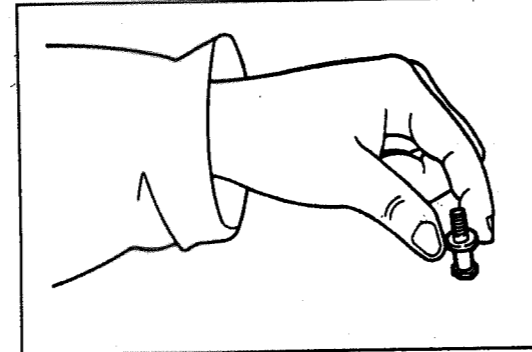

G2FU00095-99999

(2) Assemble the choke lever on the fast idle cam set screw.

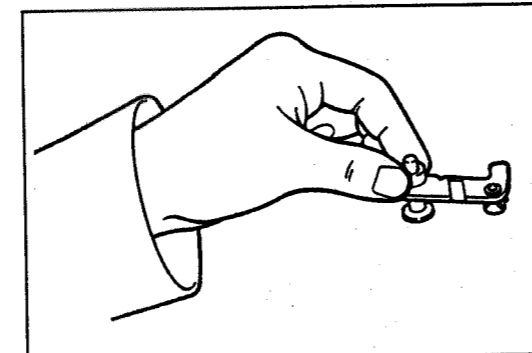

G2FU00096-99999

(3) Install the choke lever return spring.

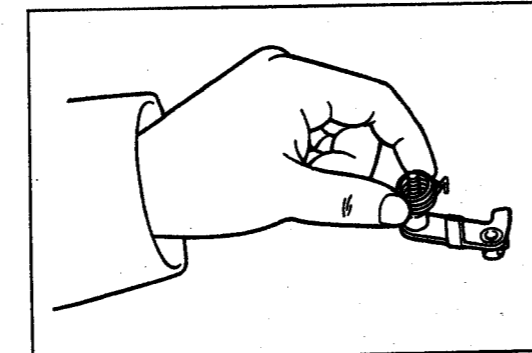

G2FU00097-99999

(4) Insert the collar in place.

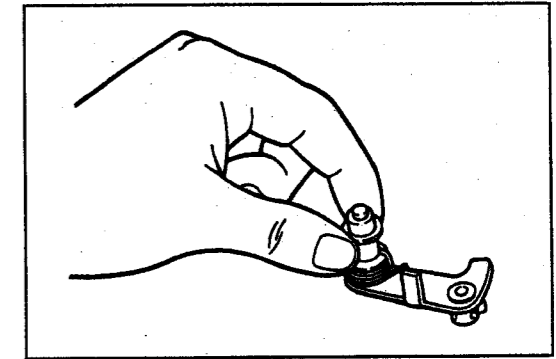

G2FU00098-99999

(5) Assemble the fast idle cam.

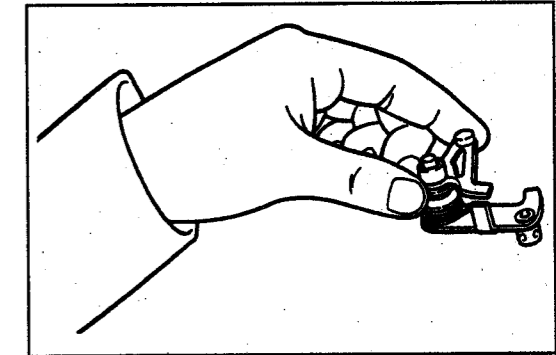

G2FU00099-99999

(6) Install the choke lever return spring bracket. Attach the return spring to the bracket and choke lever.

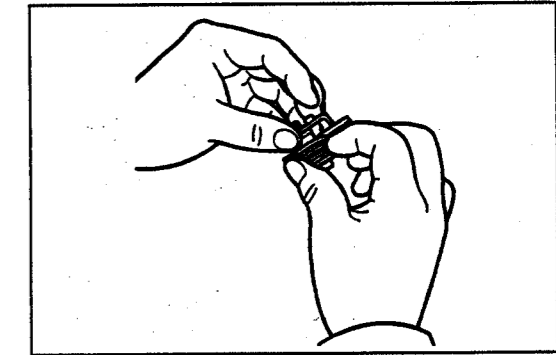

G2FU00100-99999

(7) Install the fast idle cam set screw in the carburetor body.

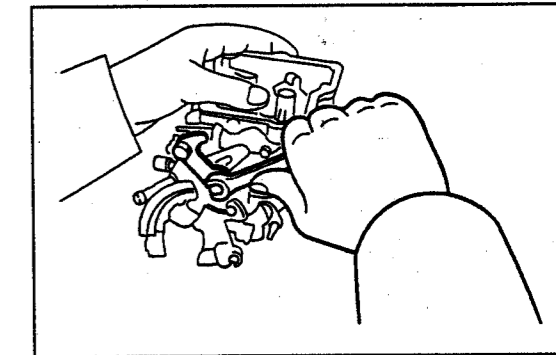

G2FU00101-99999

14. Attach the throttle return spring to the choke lever spring bracket.

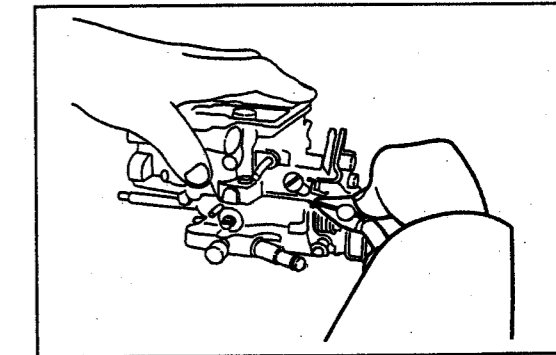

G2FU00102-99999

15. Installation of secondary throttle diaphragm
 (1) Connect the rubber hose to the diaphragm.

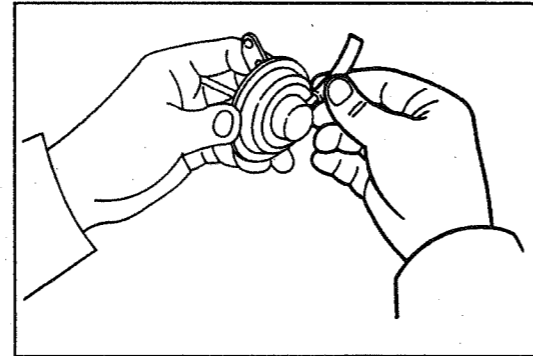

G2FU00103-99999

(2) Attach the other end of the rubber hose that has been connected to the diaphragm to the carburetor body.

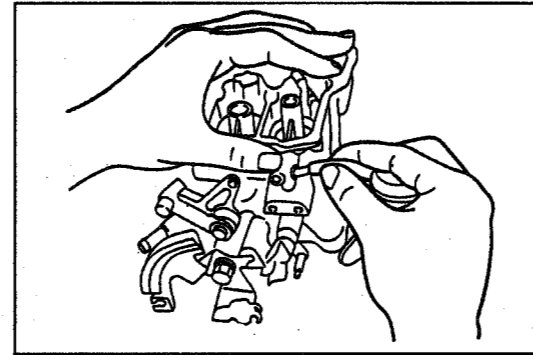

G2FU00104-99999

(3) Install the diaphragm to the carburetor body.

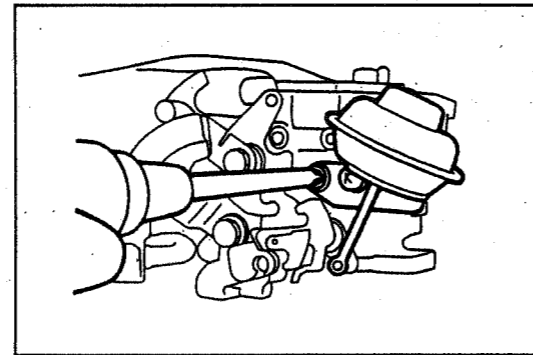

G2FU00105-99999

(4) Connect the diaphragm rod and install the washer and snap ring.

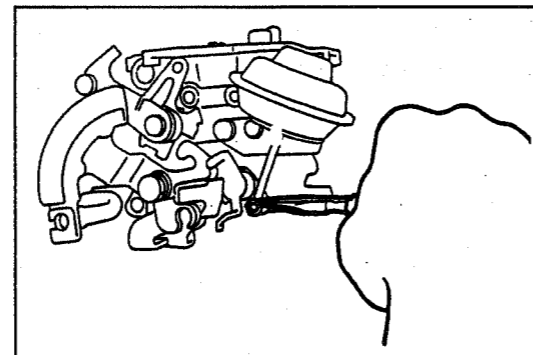

G2FU00106-99999

16. Installation of throttle positioner
 (1) Install the collar on the throttle shaft.

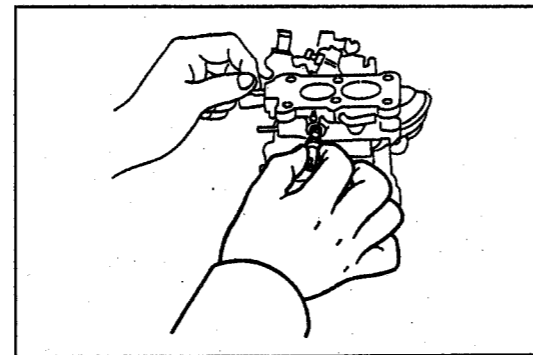

G2FU00107-99999

(2) Install the throttle return spring on the throttle shaft.

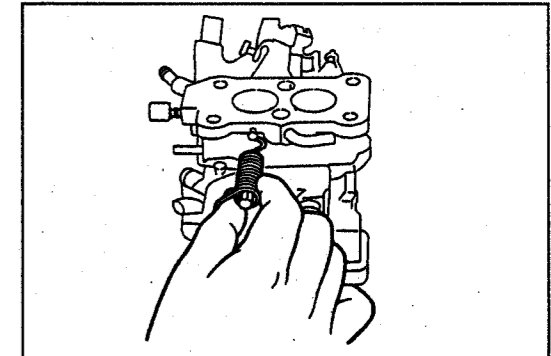

G2FU00108-99999

(3) Install the collar and thrust washer on the throttle shaft.

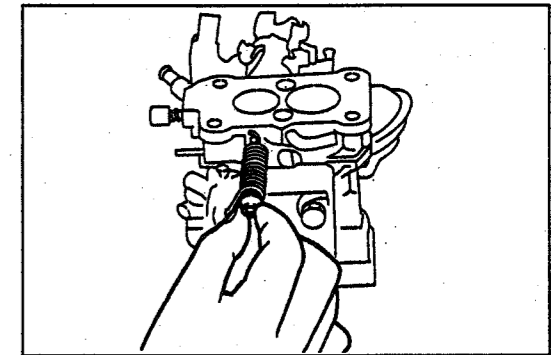

G2FU00109-99999

(4) While installing the dashpot lever on the throttle shaft, attach the return spring to the dashpot lever.

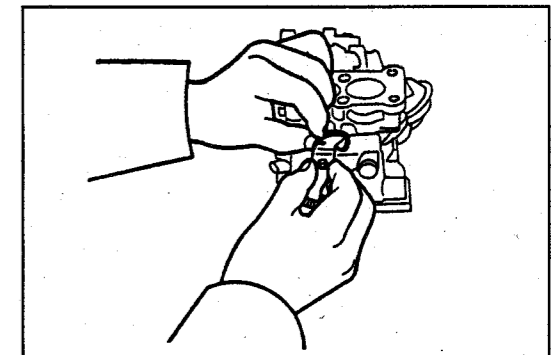

G2FU00110-99999

(5) Install the attaching nut with a new washer interposed.
 (6) Tighten the attaching nut.

CAUTION:

- Be sure to prevent the throttle shaft from turning during tightening.

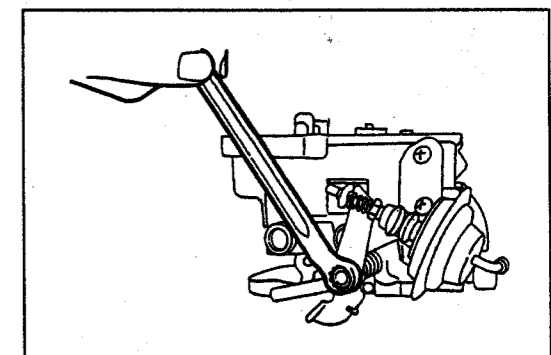

G2FU00111-99999

(7) Install the throttle positioner with the two attaching screws.

CAUTION:

- Be very careful not to damage the rubber boot section of the throttle positioner during the installation.

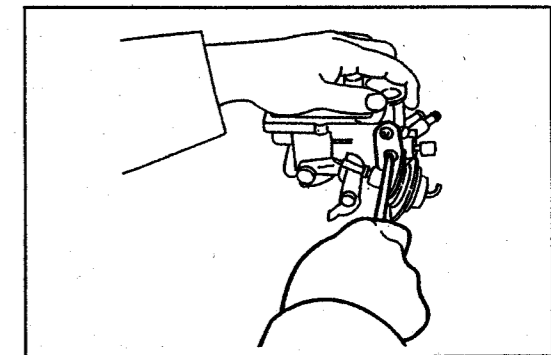

G2FU00112-99999

17. Attach the acceleration pump return spring in the carburetor.

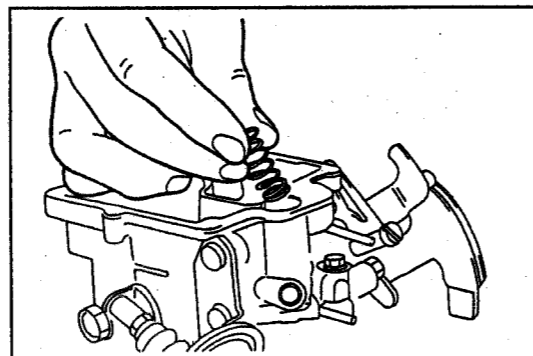

G2FU00113-99999

18. Assemble the ball, spring and discharge weight in the carburetor.

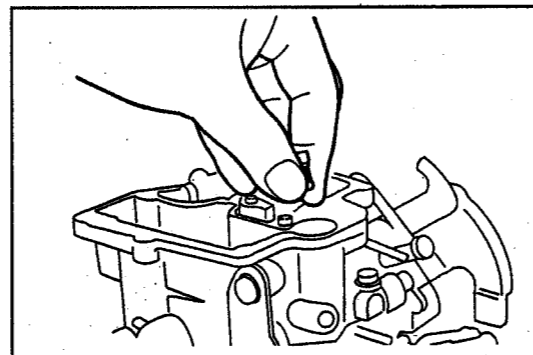

G2FU00114-99999

19. Assemble the accelerating pump.

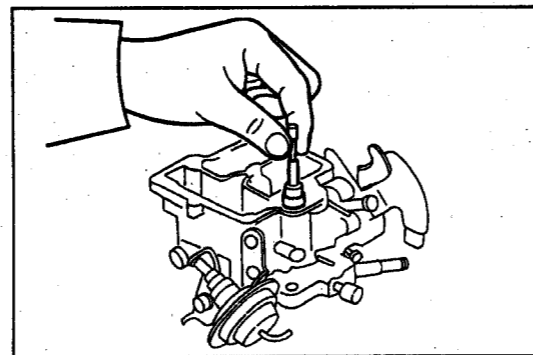

G2FU00115-99999

20. Install a new gasket on the carburetor body.

NOTE:

- Be sure to use a new gasket.

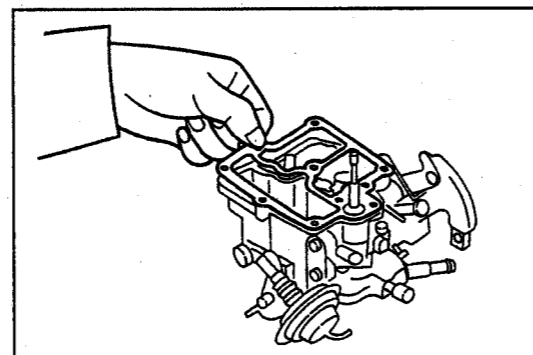

G2FU00116-99999

21. Install the solenoid valve in the carburetor body with a new gasket interposed.

CAUTION:

- Do not twist the solenoid valve wire during the installation.

NOTE:

- Be sure to use a new gasket.

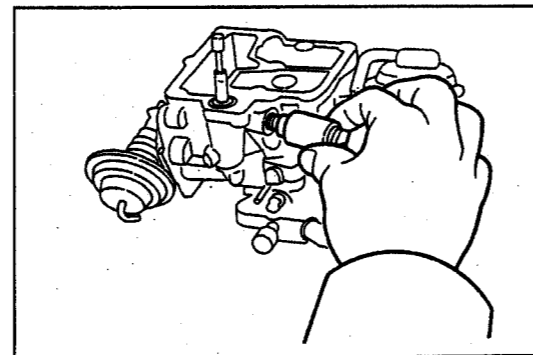

G2FU00117-99999

ASSEMBLY OF AIR HORN

1. Install the needle valve seat to the air horn with a new gasket interposed.

NOTE:

- Be sure to use a new gasket.

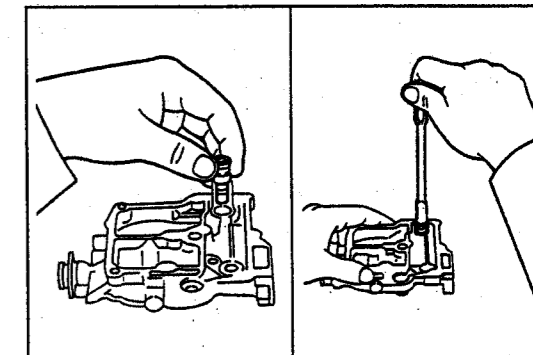

G2FU00118-99999

2. Insert the power piston spring into the air horn.

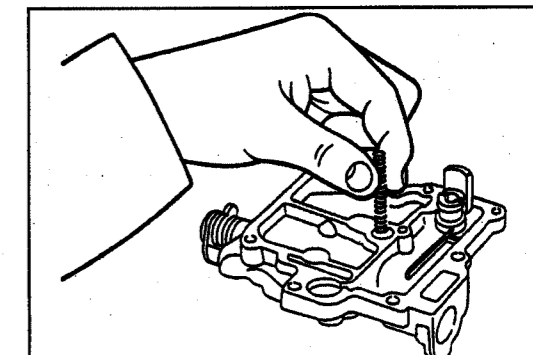

G2FU00119-99999

3. While inserting the power piston into the air horn, install the retainer plate.

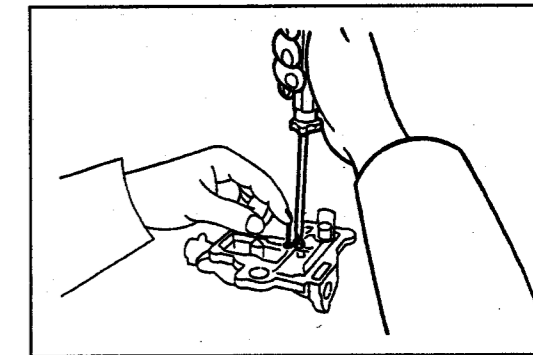

G2FU00120-99999

4. Remove the snap pin for pulling-off needle valve use.

5. Insert the needle valve into the valve seat.

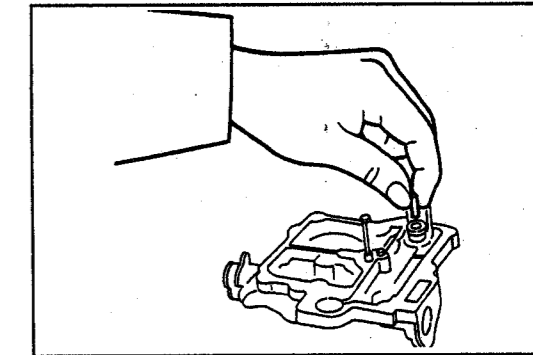

G2FU00121-99999

6. Install the float to the air horn with the float lever pin.

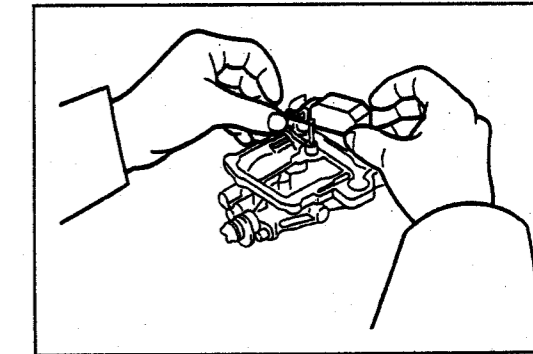

G2FU00122-99999

7. Adjustment of float level

- (1) Check the dimension under the float's own weight, using the following SST.

Dimension Under Float's Own Weight:

8 mm (0.315 inch)

SST: 09240-00014-000

Adjust the dimension under the float's own weight by bending the float lever section of the float if the measured value fails to conform to the specified value.

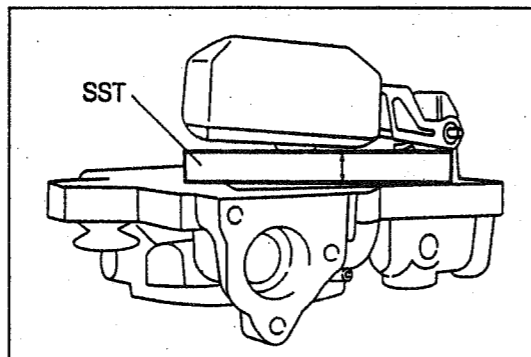

G2FU00123-99999

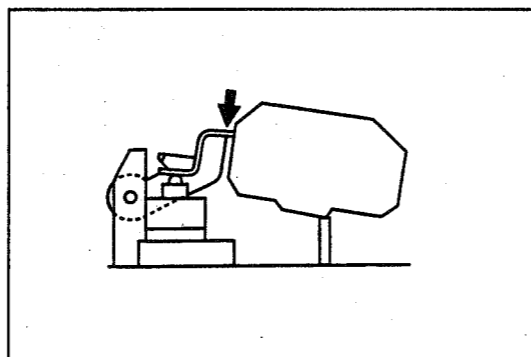

G2FU00124-99999

- (2) Check the lip dimension, using the following SST.

Lip Dimension: 1.6 mm (0.63 inch)

SST: 09240-00020-000

Adjust the lip dimension by bending the lever of the float if the measured value fails to conform to the specified value.

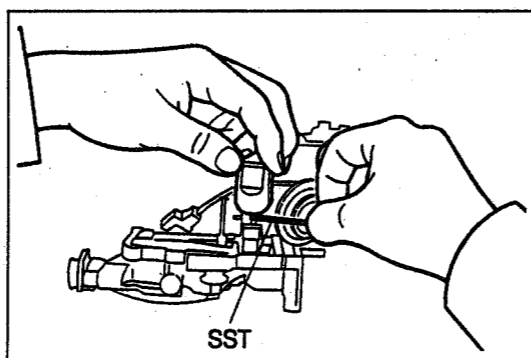

G2FU00125-99999

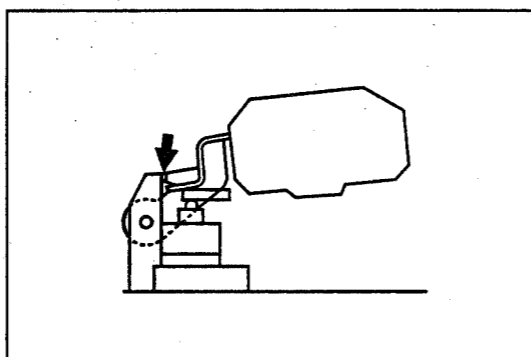

G2FU00126-99999

- (3) Remove the float by removing the float lever pin.
 (4) Pull out the needle valve.
 (5) Install the snap pin for pulling-off use to the needle valve.
 (6) Install the needle valve to the air horn.

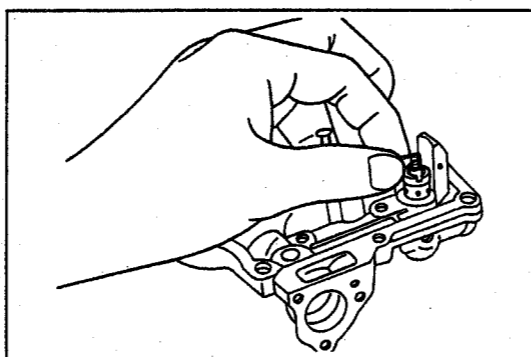

G2FU00127-99999

- (7) Install the float to the air horn with the float lever pin.

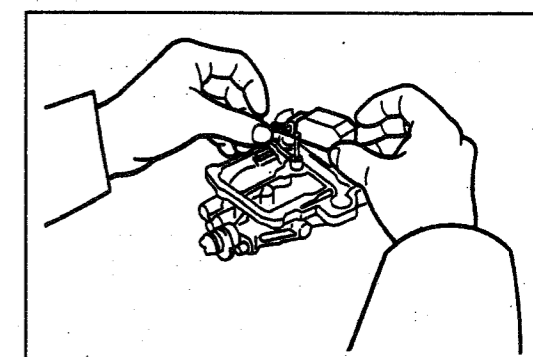

G2FU00128-99999

8. Install the air horn to the carburetor body with the attaching screws.

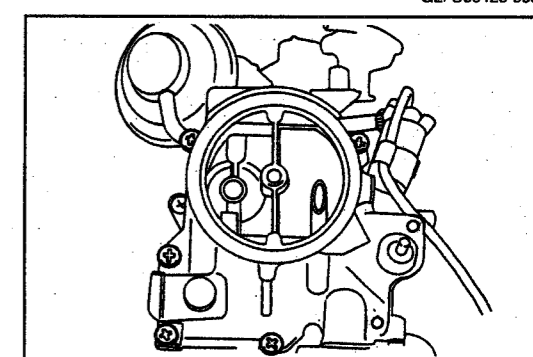

G2FU00129-99999

9. Install the thermostatic valve.

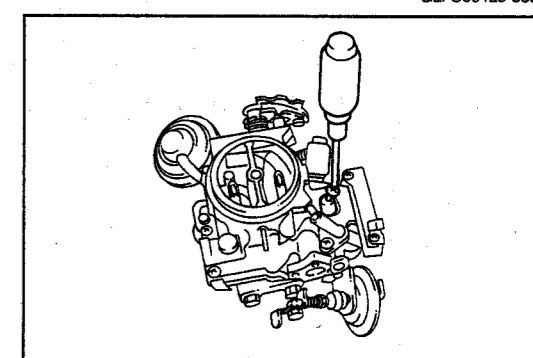

G2FU00130-99999

10. Install the outer vent valve with a new gasket interposed.
NOTE:
 • Be sure to use a new gasket.

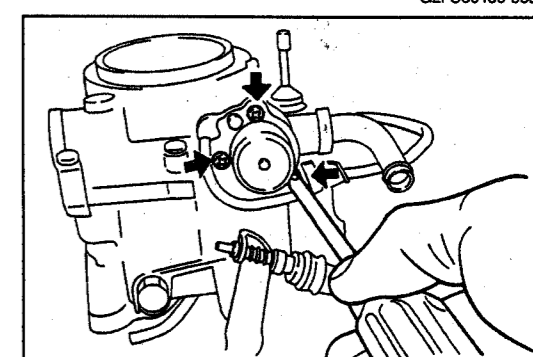

G2FU00131-99999

11. Connect the outer vent terminal to the connector.

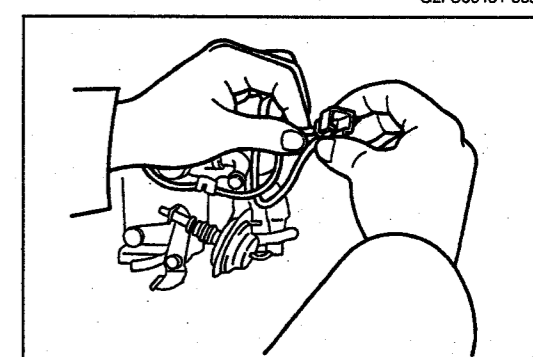

G2FU00132-99999

12. Install the choke opener to the air horn with the attaching screws.

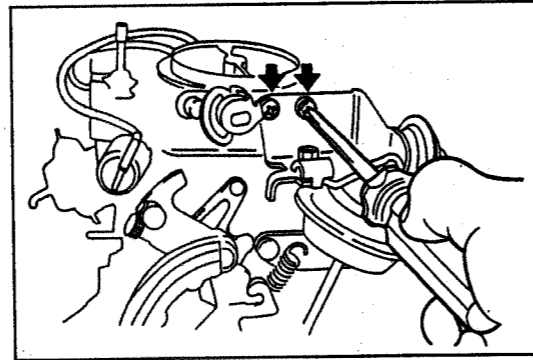

G2FU00133-99999

13. Install the throttle return spring.

NOTE:
• Be very careful not to scratch the spring.

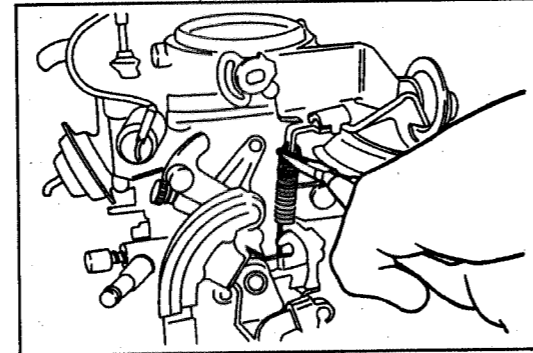

G2FU00134-99999

14. Install the thrust washers to each side of the fast idle cam link.

15. Install the fast idle cam link.

16. Attach the snap ring.

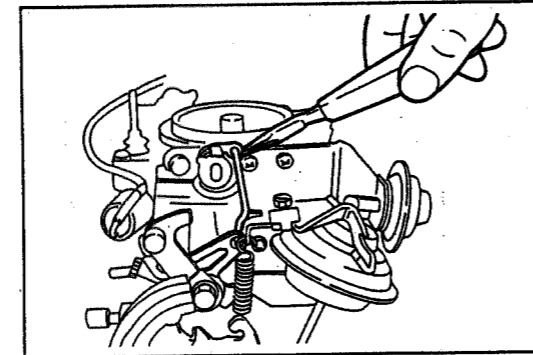

G2FU00135-99999

17. Install the washer to the choke opener link.

18. Connect the choke opener link to the choke valve.

19. Install the washer to the choke opener link.

20. Attach the snap ring.

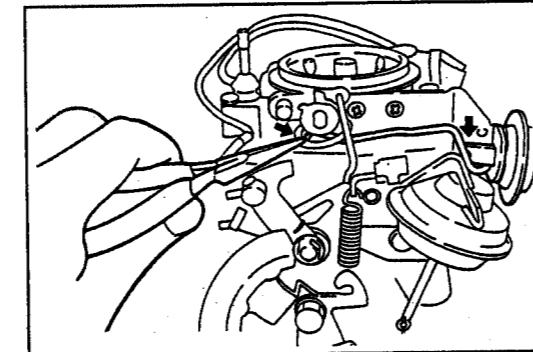

G2FU00136-99999

21. Install the washer to the accelerating pump rod.

22. Connect the pump rod to the throttle adjusting lever.

23. Connect the accelerating pump lever to the accelerating pump.

24. Connect the accelerating pump lever to the air horn with the attaching bolt.

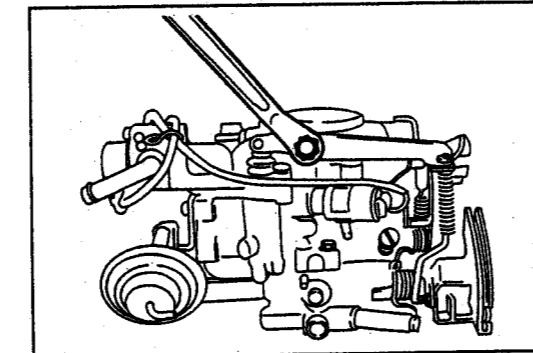

G2FU00137-99999

25. Attach the harness clamp.

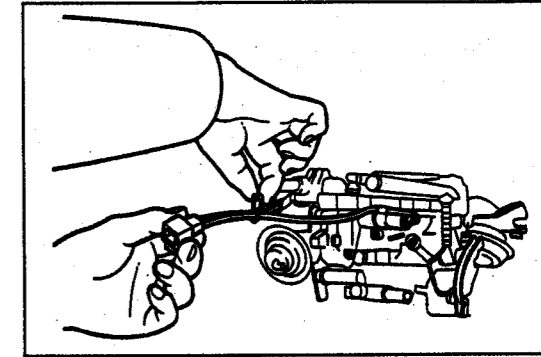

G2FU00138-99999

ADJUSTMENT OF CARBURETOR

1. Inspection of throttle valve opening angle

(1) Visually inspect the valve opening angle when the primary throttle valve is opened fully.
Full Opening Angle: $90^\circ \pm 1^\circ$

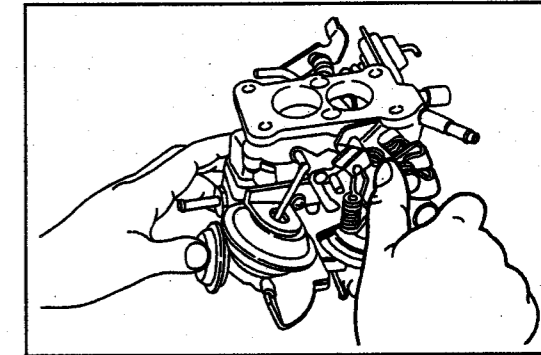

G2FU00139-99999

Adjust the opening angle by bending the throttle lever stopper if the measured value fails to conform to the specified value.

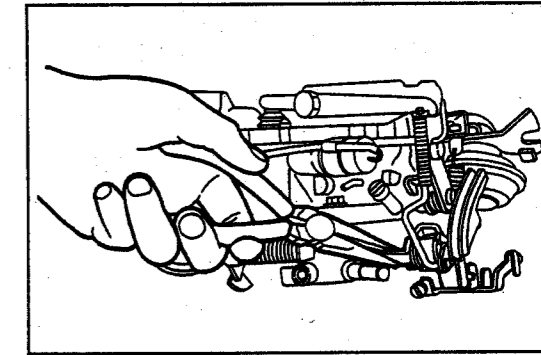

G2FU00140-99999

(2) Visually inspect the valve opening angle when the secondary throttle valve is opened fully.
Full Opening Angle: $80^\circ \pm 1^\circ$

Adjust the opening angle by bending the throttle lever stopper if the measured value fails to conform to the specified value.

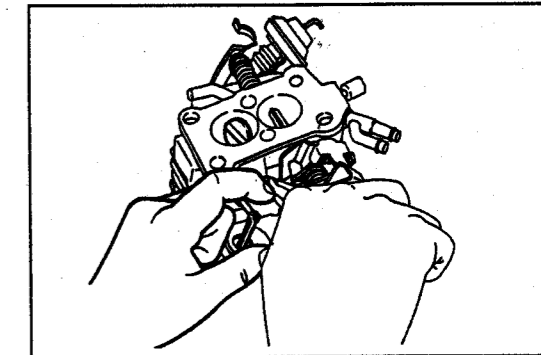

G2FU00141-99999

2. Inspection of kick-up opening angle

Measure the opening angle of the secondary valve when the primary throttle valve is opened fully, using the following SST.

SST: 09240-00014-000
Kick-Up Opening Angle: $23^\circ \pm 1^\circ$

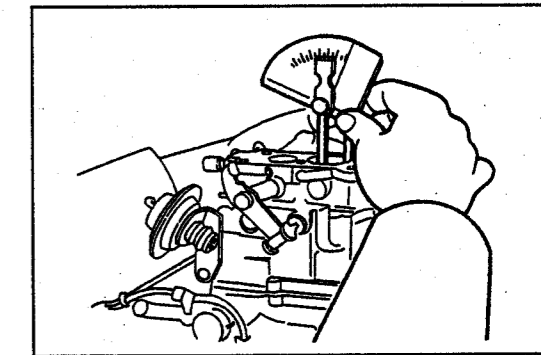

G2FU00142-99999

Adjust the kick-up opening angle by bending the secondary throttle lever if the measured value fails to conform to the specified value.

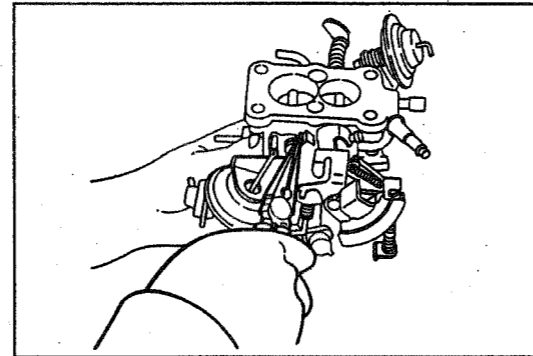

G2FU00143-99999

3. Inspection of choke opener

- (1) Check to see if the choke valve angle conforms to the specified value when the choke opener keeps in an operating state.
Specified Value: $30^\circ \pm 2^\circ$

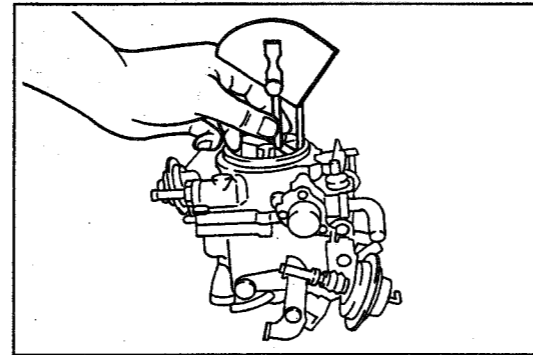

G2FU00144-99999

- (2) Adjust the choke angle by bending the choke opener link if its measured value fails to conform to the specified value.

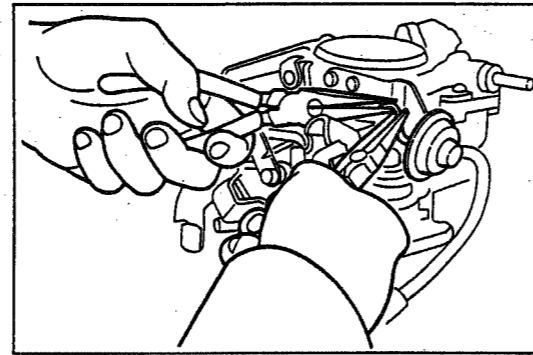

G2FU00145-99999

- 4. Adjust the throttle valve opening angle of the idle position so that it may become 11° by turning the throttle valve adjusting screw.

NOTE:

- Be sure to apply a negative pressure to the throttle positioner so as to keep it in an operating state.

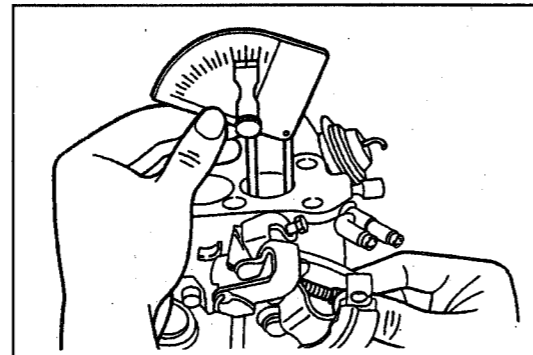

G2FU00146-99999

- 5. Adjust the throttle valve opening angle to the specified value under the condition that a negative pressure is not applied to the throttle positioner.

Specified Value: $16 \pm 1^\circ$

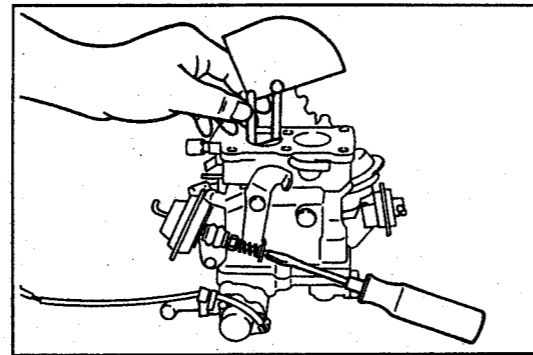

G2FU00147-99999

INSTALLATION OF CARBURETOR

1. Inspection of heat insulator
Visually inspect the gasket surface of the heat insulator. Replace the heat insulator with a new one if it exhibits damage.
2. Install the carburetor to the intake manifold with the heat insulator interposed.
Tighten the attaching nuts to the specified torque.
Tightening Torque: 14.7 - 21.6 N·m
(1.5 - 2.2 kgf-m, 10.8 - 15.9 ft-lb)
3. Connect the outer vent valve connector of the solenoid valve and the throttle position sensor connector.
4. Connect the fuel hoses and vacuum hoses to the carburetor
5. Connect the choke cable to the carburetor.
6. Connect the accelerator cable to the carburetor.
Adjust the axial play of the accelerator cable to 3 - 8 mm (0.12 - 0.31 inch).
7. Install the air cleaner to the engine.
(See page FU-8)
8. Fill coolant.
(Refer to the CO section of the service manual.)
9. Connect the ground cable terminal to the negative (-) terminal of the battery.
10. Tune up the engine.

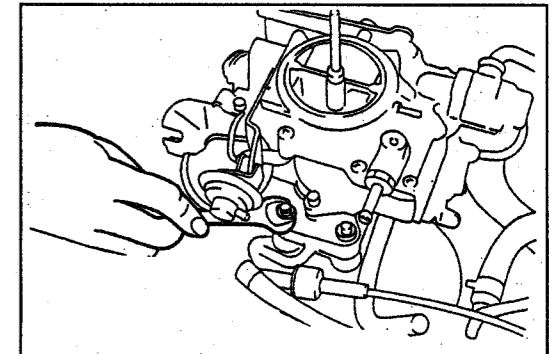

G2FU00148-99999

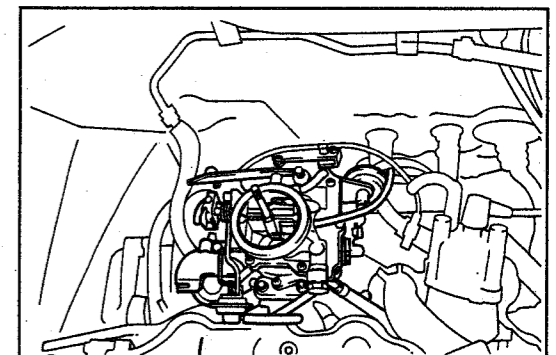

G2FU00149-99999

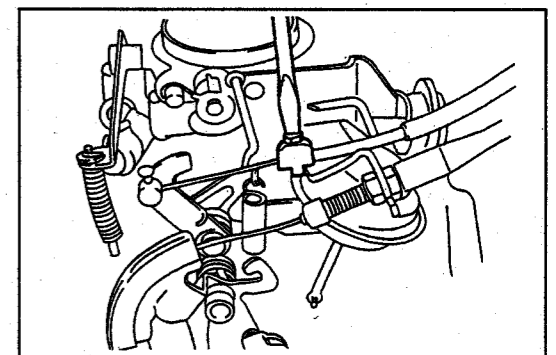

G2FU00150-99999

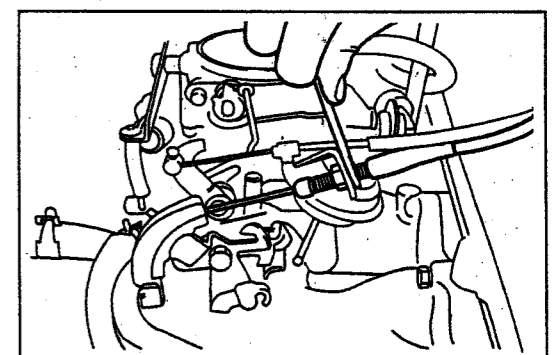

G2FU00151-99999

FUEL PUMP

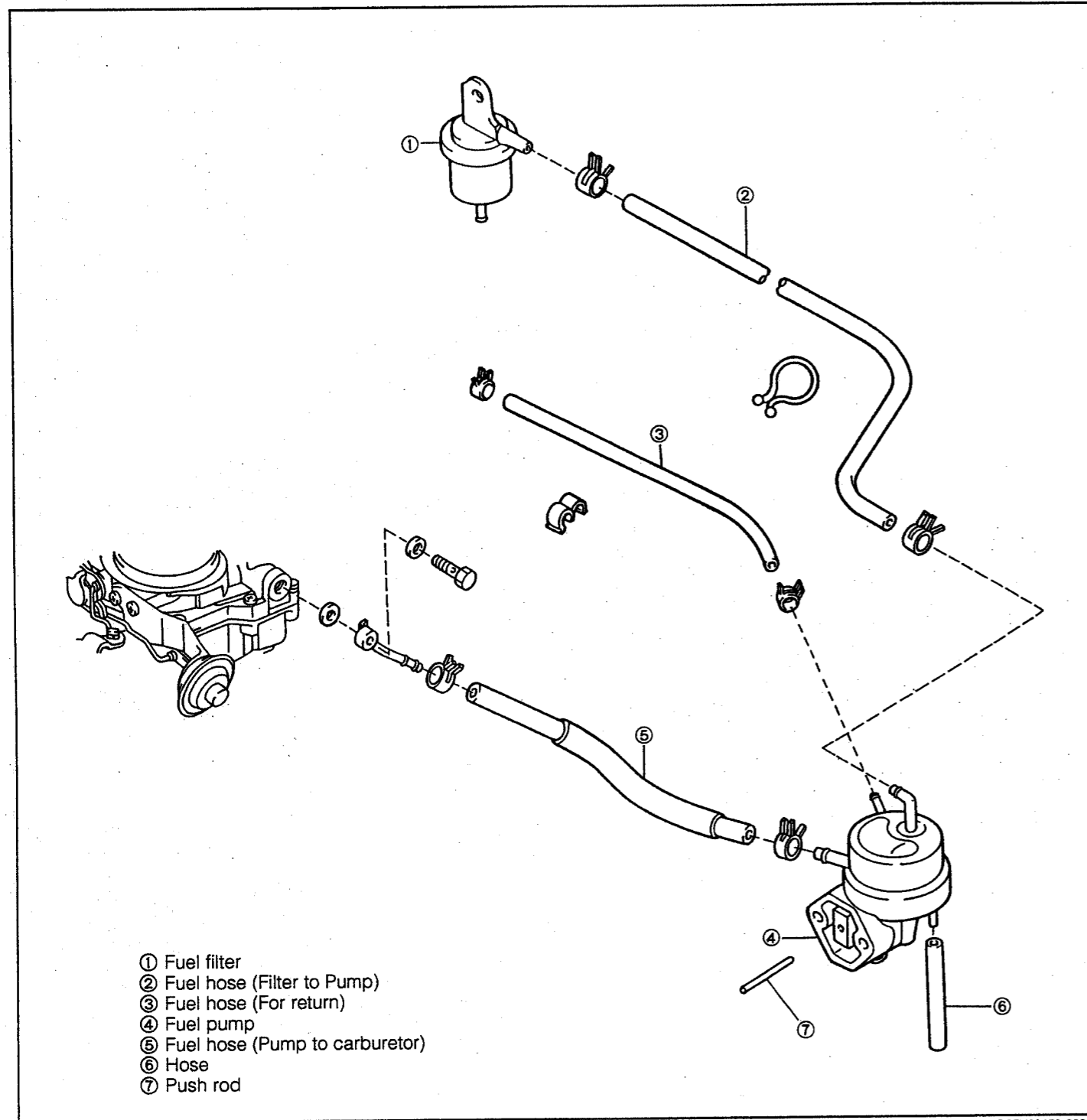

- ① Fuel filter
- ② Fuel hose (Filter to Pump)
- ③ Fuel hose (For return)
- ④ Fuel pump
- ⑤ Fuel hose (Pump to carburetor)
- ⑥ Hose
- ⑦ Push rod

G2FU00153-99999

IN-VEHICLE INSPECTION

WARNING:

- Do not perform the inspection at a poor ventilated area.
- Do not perform the inspection near open flame.

1. Open the fuel filler cap.
2. Disconnect the fuel inlet hose from the fuel pump.
3. Plug the disconnected hose so that no fuel will flow out.

G2FU00154-00000

4. Connect a vacuum meter or a MityVac to the fuel inlet of the fuel pump.
5. Disconnect the connector of the distributor.

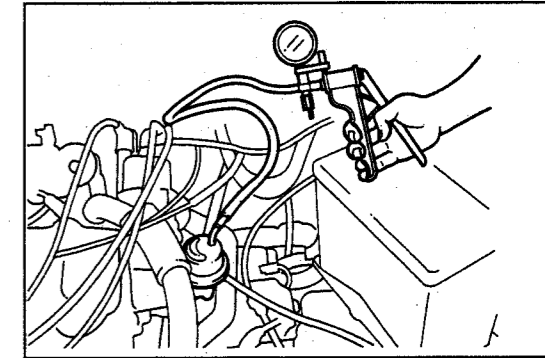

G2FU00155-99999

6. Depress the accelerator pedal fully. Read the negative pressure while the engine is being cranked by means of the starter motor. Check to see if the measured value is the specified value or more.

**Specified Negative Pressure: More than 13.3 kPa
(100 mmHg,
3.9 inchHg)**

If the negative pressure is less than the specified value, replace the fuel pump after checking the push rod of the fuel pump and the push rod stroke.

7. Connect the connector of the distributor.
8. Connect the fuel inlet hose to the fuel pump. Attach a new hose band.
9. Close the fuel filler cap.

G2FU00156-00000

UNIT INSPECTION OF FUEL PUMP

1. Removal of fuel pump

WARNING:

- Do not perform the inspection at a poor ventilated area.
- Do not perform the inspection near open flame.

- (1) Open the fuel filler cap.
- (2) Disconnect the fuel hoses from the fuel pump.

NOTE:

- Plug the disconnected hose so that no fuel will flow out.

- (3) Remove the fuel pump by removing the attaching nuts.

NOTE:

- Since the engine oil will flow out, be sure to apply a suitable cloth so that no engine oil may splash on the starter and so forth.

- (4) Remove the insulator.

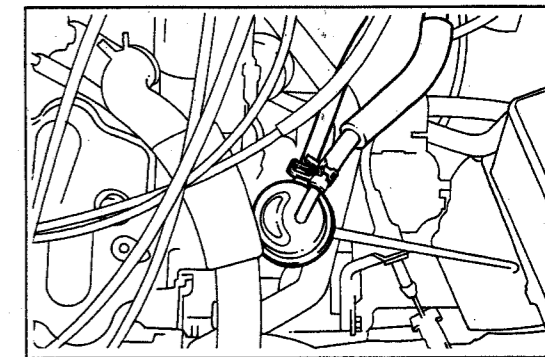

G2FU00157-99999

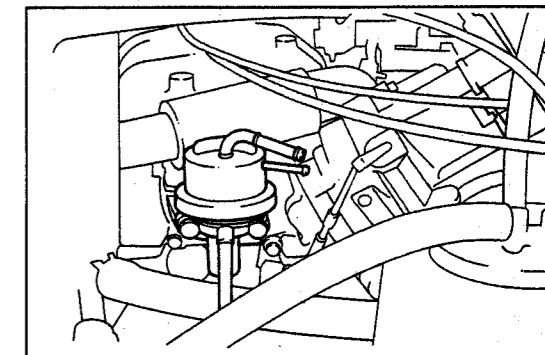

G2FU00158-99999

- (5) Remove any gasket material remaining on the fuel pump and fuel pump attaching surface of the cylinder head.

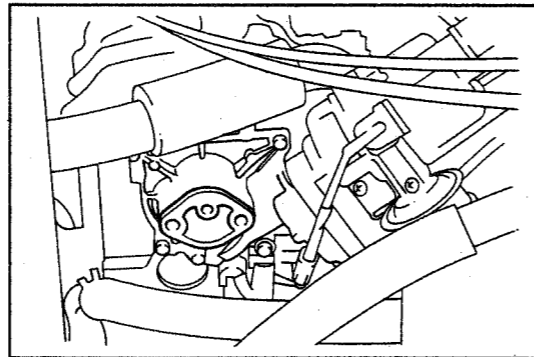

G2FU00159-99999

2. Inspection of fuel pump

CAUTION:

- Prior to check, add a small amount of fuel into the fuel pump. The inspection should be performed under a condition that the valve is wet. When the valve is dry, the following inspection can not be performed correctly.

WARNING:

- Never work on the fuel system in proximity of fire.
- Never allow any fire to be brought near the working site.

- (1) Ensure that air continuity exists when you blow air from the inlet side of the fuel pump.

Replace the fuel pump if no air continuity exists.

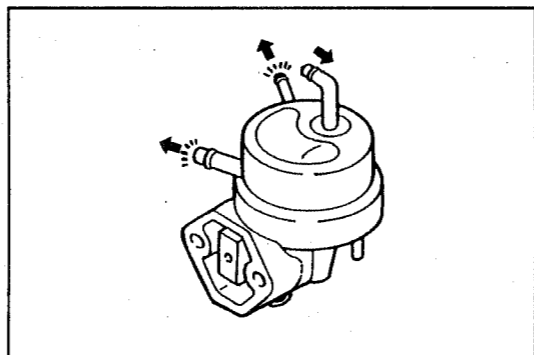

G2FU00160-00000

- (2) Install a MityVac to the inlet side of the fuel pump and apply a negative pressure. Ensure that the applied pressure is retained.

Replace the fuel pump if the pressure is not retained.

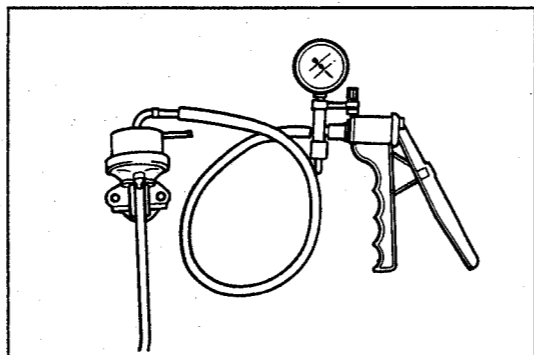

G2FU00161-99999

- (3) Plug the inlet and return pipe of the fuel pump. Connect a MityVac to the outlet pipe and apply a negative pressure. Ensure that the applied pressure is retained.

Replace the fuel pump if the pressure is not retained.

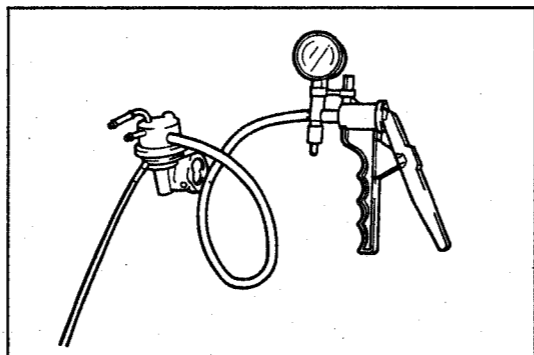

G2FU00162-99999

G2FU00163-99999

- (4) Visually inspect the push rod-contact-surface of the fuel pump for wear.

Replace the fuel pump if the push rod contact surface of the fuel pump exhibits wear.

NOTE:

- When the contact surface is not a mirror-like surface, it means that the contact surface is worn out.

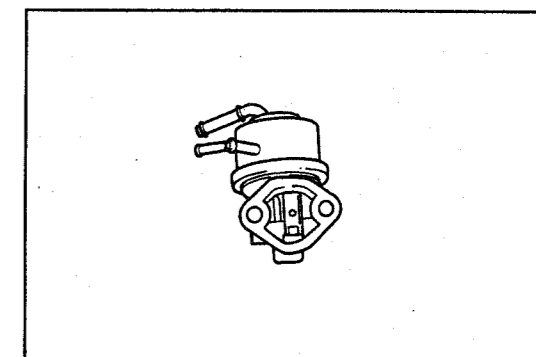

G2FU00164-99999

3. Inspection of fuel pump push rod
Ensure that the overall length of the push rod is the specified value or more.

Minimum Length: 31.1 mm (1.224 inch)

<Reference>

Standard Length: 31.6 - 31.8 mm
(1.244 - 1.252 inch)

Replace the push rod if its overall length is less than the specified minimum length.

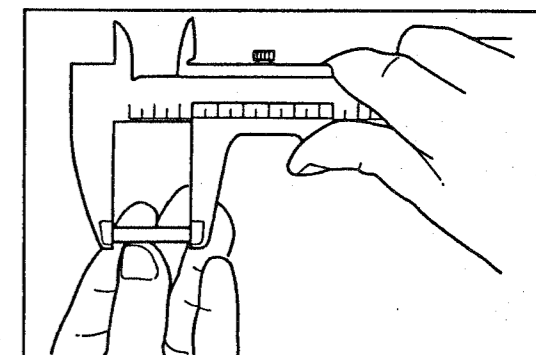

G2FU00165-99999

4. Checking fuel pump cam for wear

- (1) Insert a good push rod into the distributor housing.
- (2) Turn the crankshaft two turns (i.e. turn the camshaft one turn). Measure the maximum amount as well as the minimum amount of protrusion between the distributor housing's edge and the tip-end the push rod.

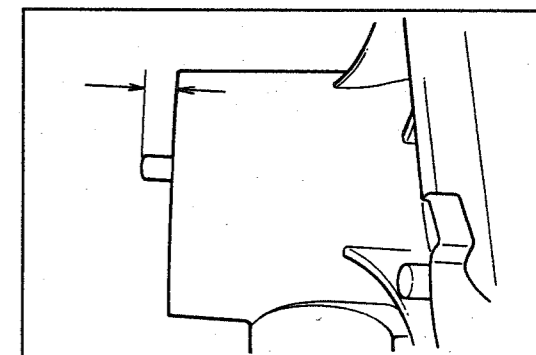

G2FU00166-99999

- (3) If the amount of protrusion is less than limit, replace the fuel pump drive cam.

Maximum Amount of Protrusion:

STD 10.5 - 11.5 mm (0.4134 - 0.4528 inch)

Limit 10.0 mm (0.3937 inch)

Minimum Amount of Protrusion:

STD 8.5 - 9.5 mm (0.3346 - 0.3740 inch)

Limit 8.0 mm (0.3150 inch)

Stroke: 2.0 mm (0.0787 inch)

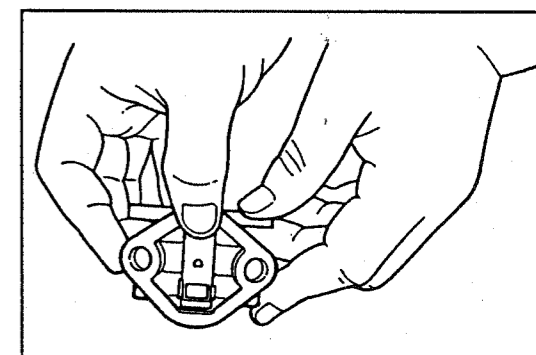

G2FU00167-99999

INSTALLATION OF FUEL PUMP

1. Remove any remaining gasket material from the insulator installation surface of the fuel pump, using a gasket scraper.

CAUTION:

- Be very careful not to damage the insulator installation surface of the fuel pump and cylinder head.

2. Wipe off any oil from the installation surface of the fuel pump and cylinder head.

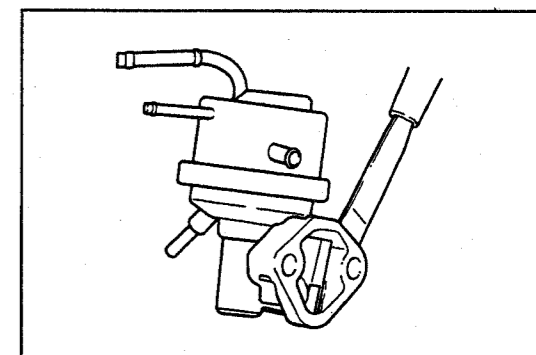

G2FU00168-99999

3. Install a new gasket and insulator to the cylinder head.

NOTE:

- Be sure to use a new insulator.
- Be certain to install the insulator in such a way that the surface marked with white paint may face upward.

4. Insert the fuel pump push rod into the cylinder head.

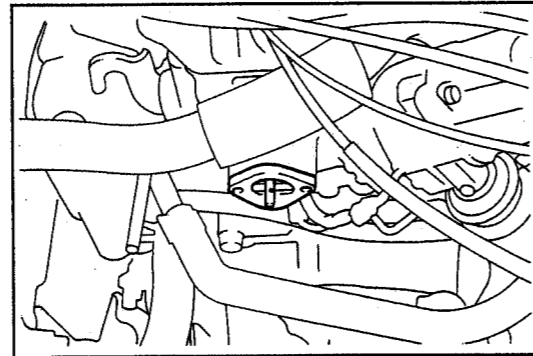

G2FU00169-99999

5. Install the fuel pump to the cylinder head with the new gasket.

6. Tighten the attaching nuts of the fuel pump evenly.

Tightening Torque: 14.7 - 21.6 N·m
(1.5 - 2.2 kgf-m, 10.8 - 15.9 ft-lb)

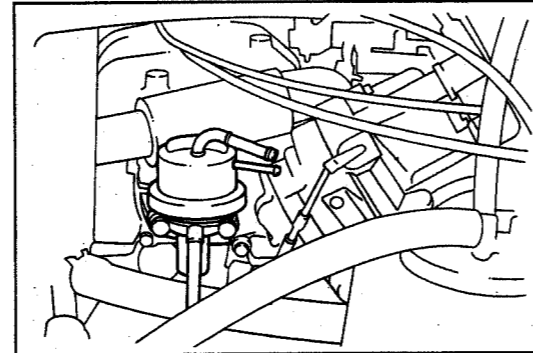

G2FU00170-99999

NOTE:

- If the hose band is displaced, be sure to install the hose band correctly.

7. Connect the fuel hoses to the fuel pump. Attach the hose bands.

8. Connect the connector of the distributor.

9. Start the engine. Ensure that the engine exhibits no fuel leakage.

Repair any leaky points, as required.

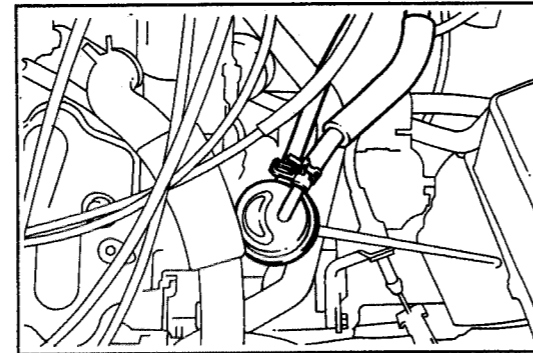

G2FU00171-99999

FUEL FILTER

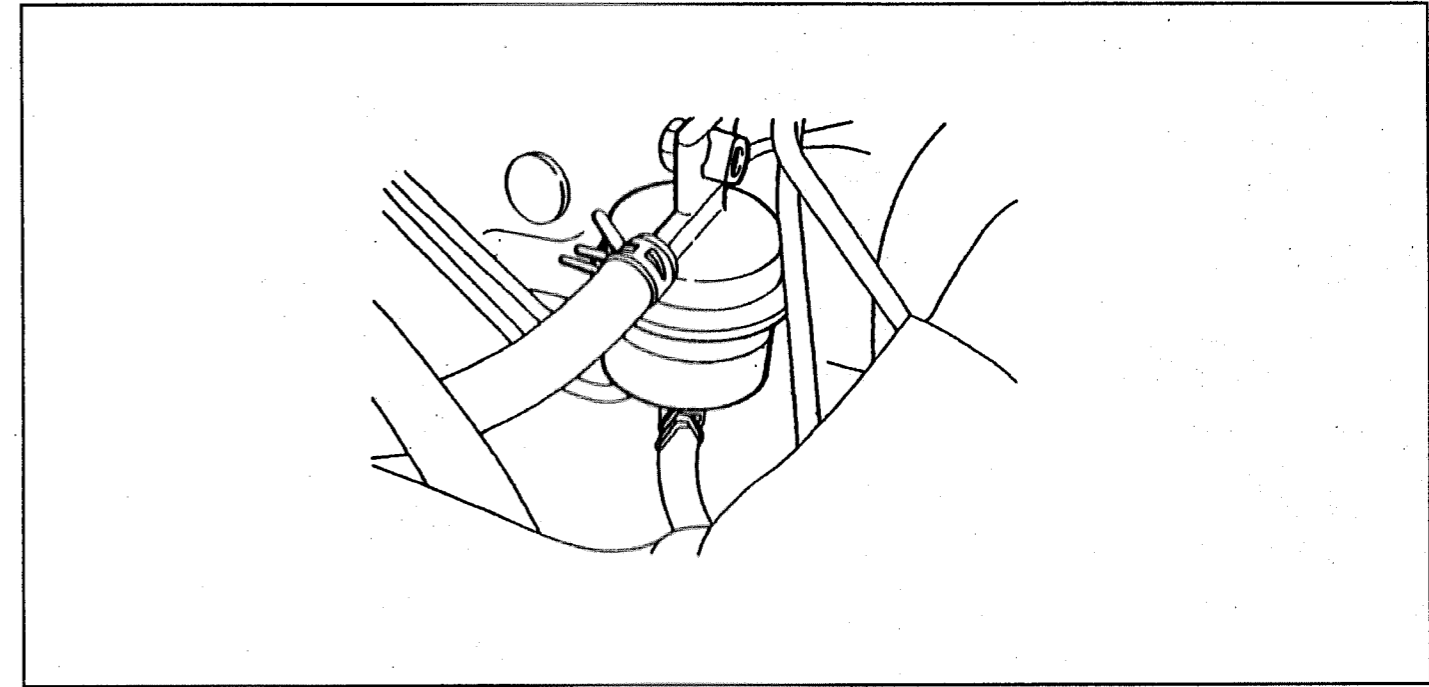

G2FU00172-99999

IN-VEHICLE INSPECTION

1. Start the engine.
2. Check the fuel level of the fuel filter. Check to see if the fuel level comes at the upper side of the fuel filter. Replace the fuel filter if the fuel level has reached the upper side of the fuel filter.
3. Stop the engine.

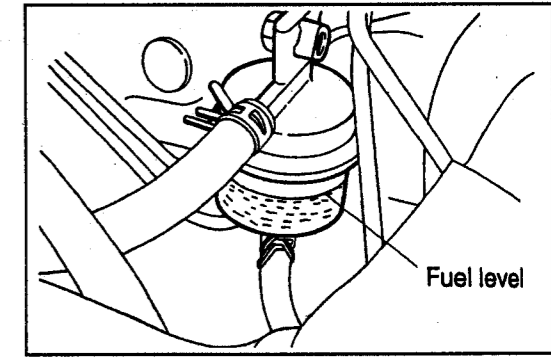

G2FU00173-99999



REPLACEMENT OF FUEL FILTER

WARNING:

- Never work on the fuel system in proximity of a fire.
- Never allow any fire to be brought near the working site.

(Refer to the MA section of the service manual for replacement procedure of the fuel filter.)

SST (Special Service Tools)

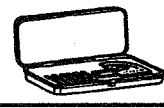
Shape	Part No. and Name	Purpose	Remarks
	09860-11011-000 Carburetor screwdriver set	Overhaul of carburetor	
	09243-00020-000 Idle adjust wrench	Adjustment of idle mixture adjusting screw	
	09240-00020-000 Wire gauge set	Adjustment of carburetor	
	09240-00014-000 Carburetor adjusting gauge set	Adjustment of carburetor	

G2FU00174-99999

SPECIFICATIONS

Carburetor	Float level	Dimension assumed by its own weight	8 mm (0.315 inch)
		Lip dimension	1.6 mm (0.063 inch)
	Throttle valve closed angle	Primary	9°
		Secondary	20°
	Throttle valve fully opened angle	Primary	90°
		Secondary	80°
	Kick-up angle		23°
	Secondary touch angle		50°
	Choke valve-to-body clearance during choke opener operating period		4.4 mm (0.173 inch)
	Throttle valve-to-body clearance with throttle valve opened fully		0.3 mm (0.012 inch)
	Throttle valve-to-body clearance during dashpot operating period		0.45 mm (0.018 inch)
	Number of backing-off of idle mixture adjusting screw		4
Solenoid valve resistance		80 - 100 Ω	
Outer vent resistance		30 - 45 Ω	
Fuel pump	Suction force at 300 rpm		100 mmHg or more (3.9 inchHg or more)
	Push rod length	Standard	31.6 - 31.8 mm (1.244 - 1.252 inch)
		Minimum	31.1 mm (1.224 inch)

G2FU00175-00000

TROUBLE SHOOTING

Problem	Possible cause	Remedy	Page
Engine will not start/hard to start (Only case where cranking by startor motor is normal)	Carburetor problems <ul style="list-style-type: none"> • Choke operation • Needle valve sticking or clogged • Vacuum hose disconnected or damage • Fuel cut solenoid valve not open • Outer vent valve not open 	Check choke system. Check float and needle. Check fuel cut solenoid valve. Check outer vent valve.	FU-3 FU-29 EC Section FU-4, 19 FU-4, 19
Rough idle or engine stalls	Carburetor problems <ul style="list-style-type: none"> • Idle speed incorrect • Slow jet clogged • Idle mixture incorrect • Fuel cut solenoid valve not open • Fast idle speed setting incorrect (Cold engine) • Choke operation • Fuel pump faulty • Fuel filter clogged • Fuel line clogged • Fuel line bent or kinked 	Adjust idle speed. Adjust idle mixture. Check fuel cut solenoid valve. Adjust fast idle speed. Check choke system.	MA Section FU-19 MA Section FU-4, 19 MA Section FU-3 FU-37 FU-41
Engine hesitates/poor acceleration	Carburetor problems <ul style="list-style-type: none"> • Float level too low • Accelerator pump faulty • Power valve faulty • Power piston faulty • Choke valve closed or open • Fuel line clogged • Fuel pump faulty • Fuel filter clogged • Fuel line clogged • Fuel line bent or kinked 	Adjust float level. Check power valve. Check power piston. Check choke system. Check fuel line. Check fuel pump. Replace fuel filter. Check fuel line. Replace fuel line.	FU-30 FU-3 FU-19 FU-19 FU-3 FU-37 FU-41
Engine dieseling (Runs after ignition switch is turned off)	Carburetor problems <ul style="list-style-type: none"> • Linkage sticking • Idle speed or fast idle speed out of adjustment • Fuel cut solenoid faulty 	Adjust idle speed or fast idle speed. Check fuel cut solenoid valve.	FU-3 MA Section FU-4, 19
Poor fuel mileage	Carburetor problems <ul style="list-style-type: none"> • Choke faulty • Idle speed too high • Power valve always open • Idle mixture incorrect Fuel leak	Check choke system. Adjust idle speed. Check power piston and valve. Adjust idle mixture. Repair if necessary.	FU-3 MA Section FU-19 MA Section
Unpleasant door	Outer vent valve always open	Check outer vent valve.	FU-4, 19

G2FU00176-00000