

# DAIHATSU G202

**MA**

## Chassis

### MAINTENANCE

<b>MAINTENANCE SCHEDULE</b> .....	<b>MA- 2</b>	LIGHTING SYSTEM .....	<b>MA-35</b>
SECTION DESCRIPTION .....	<b>MA- 2</b>	METER & GAUGE .....	<b>MA-37</b>
<b>MAINTENANCE OPERATIONS</b> .....	<b>MA- 5</b>	WIRE HARNESS .....	<b>MA-37</b>
BRAKE PEDAL .....	<b>MA- 5</b>	CLUTCH .....	<b>MA-38</b>
BRAKE FLUID .....	<b>MA- 6</b>	MANUAL TRANSMISSION .....	<b>MA-39</b>
BRAKE HOSE & TUBE .....	<b>MA- 7</b>	DRIVE SHAFT .....	<b>MA-40</b>
PARKING BRAKE LEVER .....	<b>MA- 8</b>	TIRE .....	<b>MA-41</b>
PARKING BRAKE ROD & CABLE .....	<b>MA- 9</b>	WHEEL .....	<b>MA-42</b>
FRONT BRAKE (Disc brake) .....	<b>MA-10</b>	WHEEL BEARING .....	<b>MA-42</b>
REAR DRUM BRAKE .....	<b>MA-14</b>	STEERING BALL JOINT DUST BOOT .....	<b>MA-43</b>
BRAKE BOOSTER .....	<b>MA-17</b>	GEAR BOX .....	<b>MA-43</b>
BBRAKE MASTER CYLINDER .....	<b>MA-26</b>	KNUCKLE .....	<b>MA-43</b>
PROPORTIONING VALVE .....	<b>MA-29</b>	TIE ROD AND ARM .....	<b>MA-43</b>
FUEL HOSE AND CHECK VALVE .....	<b>MA-30</b>	STEERING WHEEL .....	<b>MA-44</b>
CHASSIS GREASE & OIL .....	<b>MA-33</b>	WHEEL ALIGNMENT .....	<b>MA-45</b>
DOOR & HOOD .....	<b>MA-33</b>	SUSPENSION & LINKAGE .....	<b>MA-45</b>
MUFFLER AND EXHAUST PIPE .....	<b>MA-33</b>	SHOCK ABSORBER .....	<b>MA-46</b>
SEAT BELTS .....	<b>MA-34</b>	SUSPENSION ARM, CONTROL ARM & DUST COVER .....	<b>MA-46</b>
BATTERY .....	<b>MA-34</b>		
HORN, WIPER, WINDSHIELD WASHER & DEFROSTER .....	<b>MA-35</b>		

G2MA00001-00000

**NO. 9188**

# MAINTENANCE SCHEDULE

## SECTION DESCRIPTION

Maintenance operation:

NOTE 1. Check the odometer and the period the vehicle has been operated whichever comes first.

2. Continue periodic maintenance after 100,000 km (60,000 miles), following this schedule.

○ ... Check or inspect      ... Change or replace

Section	Inspection	× 1000 km	1	10	20	30	40	50	60	70	80	90	100	See page	
		× 1000 miles	0.6	6	12	18	24	30	36	42	48	54	60		
		Years	—	0.5	1	1.5	2	2.5	3	3.5	4	4.5	5		
Brake system	Brake booster	• Function					○					○		MA-17	
		• Rubber parts and vacuum hose replacement	Every 4 years											MA-19	
	Brake fluid	• Level	○	○	○	○	○	○	○	○	○	○	○	○	MA-6
		• Change	Every 1 years											MA-6	
	Brake hose & tube	• Leakage Loose clamps Damage	○	○	○	○	○	○	○	○	○	○	○	○	MA-7
		• Hose change	Every 4 year											MA-7	
	Brake drum	• Wear Damage					○					○		MA-10	
	Brake lining	• Drum-to-lining clearance Wear			○		○		○		○		○		MA-14
	Brake disk	• Wear Damage					○								MA-11
	Brake pad (disk brake)	• Wear Damage Disk-to-pad clearance			○		○		○		○		○		MA-11
		• Free play Reserve travel	○	○	○	○	○	○	○	○	○	○	○	○	MA-5
	Brake pedal	• Effectiveness		○	○	○	○	○	○	○	○	○	○	○	MA-6
		• Fluid leakage			○		○		○		○		○		MA-13 MA-16
	Master cylinder, wheel cylinder and disc caliper	• Function Damage Wear					○					○			MA-10
		• Cup and dust seal replacement	Every 2 years											MA-11	
Parking brake lever	• Working travel	○	○	○	○	○	○	○	○	○	○	○	○	MA-8	
	• Effectiveness			○		○		○		○		○		MA-8	
Parking brake rod & cable	• Tightness Rattle Damage					○					○			MA-9	
Proportioning valve	• Replacement	Every 4 years											MA-29		

Section	Inspection	× 1000 km	1	10	20	30	40	50	60	70	80	90	100	See page
		× 1000 miles	0.6	6	12	18	24	30	36	42	48	54	60	
		Years	—	0.5	1	1.5	2	2.5	3	3.5	4	4.5	5	
Chassis and Body	Chassis grease & Oil	• Condition			○		○		○		○		○	MA-33
	Door & hood	• Lock operation Tightness Damage					○				○			MA-33
	Muffler and exhaust pipe	• Damage Tightness			○		○		○		○		○	MA-33
		• Function of muffler					○				○			MA-33
Seat belt	• Operation Tightness					○				○			MA-34	
Electrical system	Battery	• Connection of terminal section Specific gravity			○		○		○		○		○	MA-34
		• Electrolyte level		○	○	○	○	○	○	○	○	○	○	MA-34
	Horn, wiper, washer & defroster	• Function			○		○		○		○		○	MA-35
	Lighting system	• Function	○	○	○	○	○	○	○	○	○	○	○	MA-35
	Meter & gauges	• Function			○		○		○		○		○	MA-37
	Wire harness	• Tightness of clamp Damage					○				○			MA-37
	Power transmission system	Clutch	• Free play Reserve travel		○	○	○	○	○	○	○	○	○	○
• Operation					○		○		○		○		○	MA-38
Manual transmission		• Oil level Oil leakage Oil change	○		○				○				○	MA-39
		• Rattle of operating mechanism					○				○			MA-39
Drive shaft	• Crack and damage of joint dust boot Tightness of connecting section			○		○		○		○		○	MA-40	
	• Rattle of spline and joint section					○				○			MA-40	
Running system	Tire	• Clacks and damage Objects caught in the tire pattern Pressure Wear	○	○	○	○	○	○	○	○	○	○	○	MA-41
		• Rotation		○	○	○	○	○	○	○	○	○	○	MA-41
	Wheel	• Damage of wheel disk					○				○			MA-42
		• Looseness of wheel hub nut			○		○		○		○		○	MA-42
	Wheel bearing	• Rattle					○				○			MA-42

Section	Inspection	× 1000 km	1	10	20	30	40	50	60	70	80	90	100	See page
		× 1000 miles	0.6	6	12	18	24	30	36	42	48	54	60	
		Years	—	0.5	1	1.5	2	2.5	3	3.5	4	4.5	5	
Steering system	Ball joint dust boot	• Damage			○		○		○		○		○	MA-43
	Gear box	• Leakage	○				○				○			MA-43
		• Tightness					○				○			MA-43
	Knuckle	• Rattle of linkage					○				○			MA-43
	Rod and arm	• Damage • Rattle • Tightness			○		○		○		○		○	MA-43
	Steering wheel	• Free play • Operation • Rattle • Tightness			○		○		○		○		○	MA-44
Wheel alignment	• Side slip test • Turning angle					○				○			MA-45	
Suspension system	Attaching portion & linkage	• Damage • Rattle • Tightness					○			○				MA-45
	Shock absorber	• Damage • Function • Oil leakage • Rattle					○				○			MA-46
	Spring	• Damage					○				○			MA-46
	Suspension arm, control arm & dust cover	• Damage • Rattle • Tightness					○				○			MA-46
Engine	Fuel line & connection	• Fuel hose replacement	Every 4 years										MA-30	
Exhaust emission control system	Check valve	• Function					○				○			MA-32

G2MA00002-00000

MAINTENANCE OPERATIONS

BRAKE PEDAL

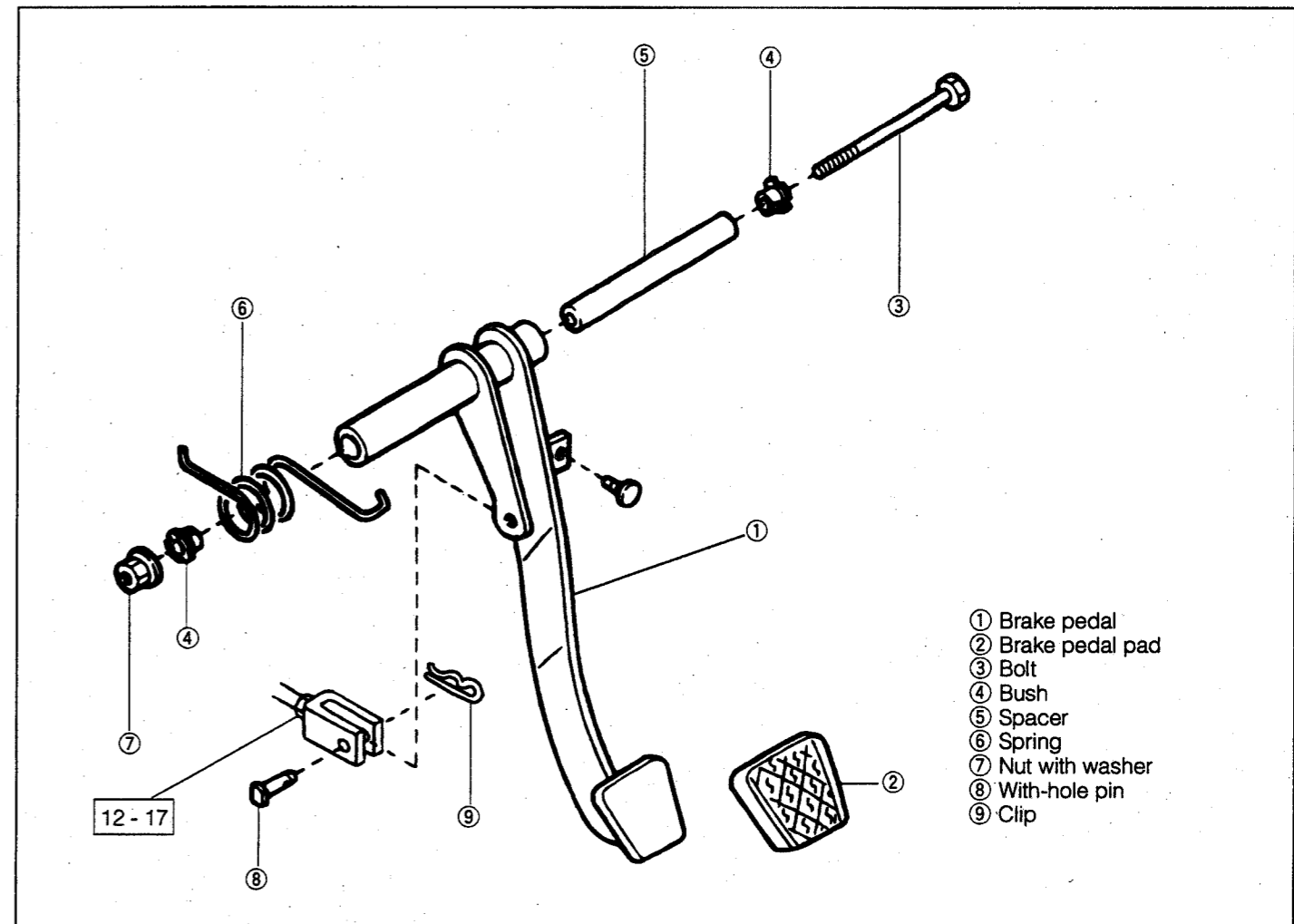

G2MA00003-00001

FREE PRAY

With the engine stopped, first reduce the vacuum in the booster by depressing the brake pedal more than five times. Then lightly and slowly depress the pedal by hand until you feel resistance and measure the free play.

Specified Value: 0.5 - 2.0 mm

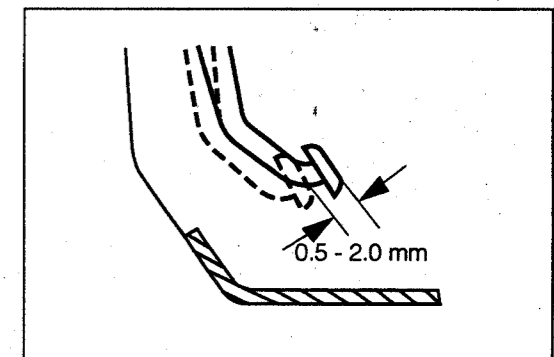

G2MA00004-00002

RESERVE TRAVEL

1. Place chocks at the wheels. Place the transmission in neutral state. With the engine running at the idle speed and with the parking brake lever released, depress the brake pedal with applying force of 300 N.
2. Measure the distance between the position where the depressed pedal stops and the floor panel.

Specified Value: 72 mm

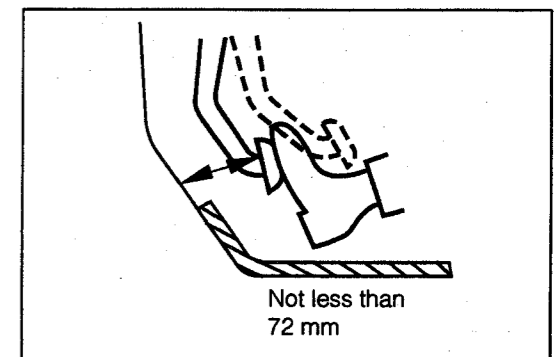

G2MA00005-00003

**EFFECTIVENESS**

1. Check that the brakes are functioning effectively, either by using the brake tester or by conducting road tests on a level road.
2. Ensure that the brakes are functioning normally without any side pull.

G2MA00006-00000

**BRAKE FLUID**

**LEVEL**

Check the brake fluid level and replenish the brake fluid to the "MAX" line of the reservoir tank, if required.

**NOTE:**

- If the brake fluid is spilled in advertently over the paint-finish surface of the vehicle, quickly wipe off the brake fluid.

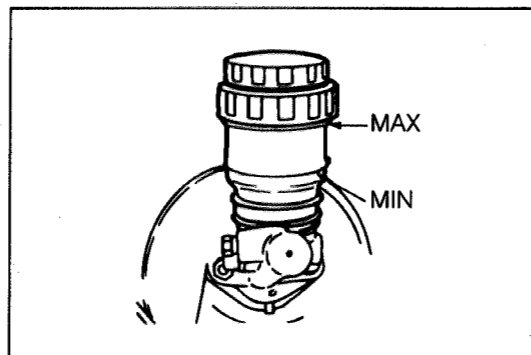

G2MA00007-00004

**CHANGE**

1. Submerge one end of a hose in a container filled with the brake fluid. Connect the other end of the hose to the wheel cylinder bleeder plug of the vehicle. Loosen the bleeder plug.
2. Release the brake fluid completely from each wheel cylinder.
3. Tighten the bleeder plug and fill the brake fluid to the "MAX" line of the tank.

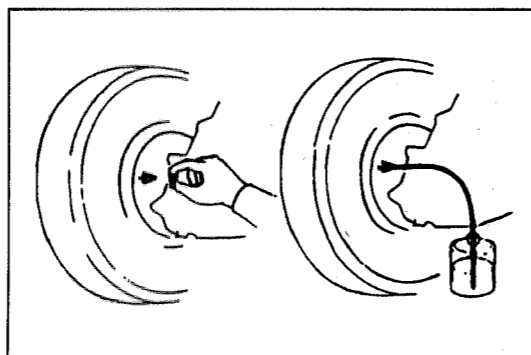

G2MA00008-00005

**AIR BLEEDING**

1. Perform the operation by two persons. One person should depress the brake pedal slowly and hold it in a depressed state.
2. The other person slackens the bleeder plug 1/3 through 1/2 turn at a time. Be sure to tighten the bleeder plug before the hydraulic pressure ceases to exist in the cylinder.
3. Repeat the step 4 and 5 above, until you no longer observe bubbles in the fluid.
4. Depress the brake pedal and check fluid leakage.

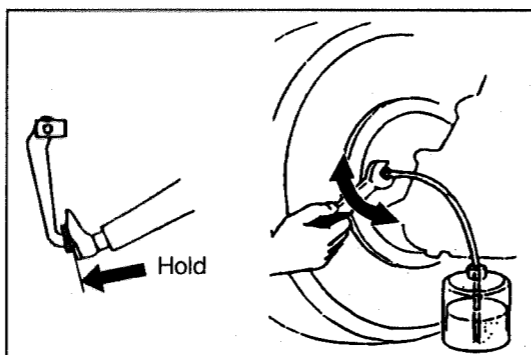

G2MA00009-00006

**BRAKE HOSE & TUBE**

**LEAKAGE, LOOSE CLAMP AND DAMAGE**

Inspect the hose for following points.

- (1) Hoses and tubes for damage, cracks
- (2) Hoses for deformation or swelling
- (3) Tubes for corrosion or rust
- (4) Tube clamps and related parts for tightness, rattle or damage
- (5) Connection for fluid leakage
- (6) Hoses for extreme bending, twisting or pulling

G2MA00010-00000

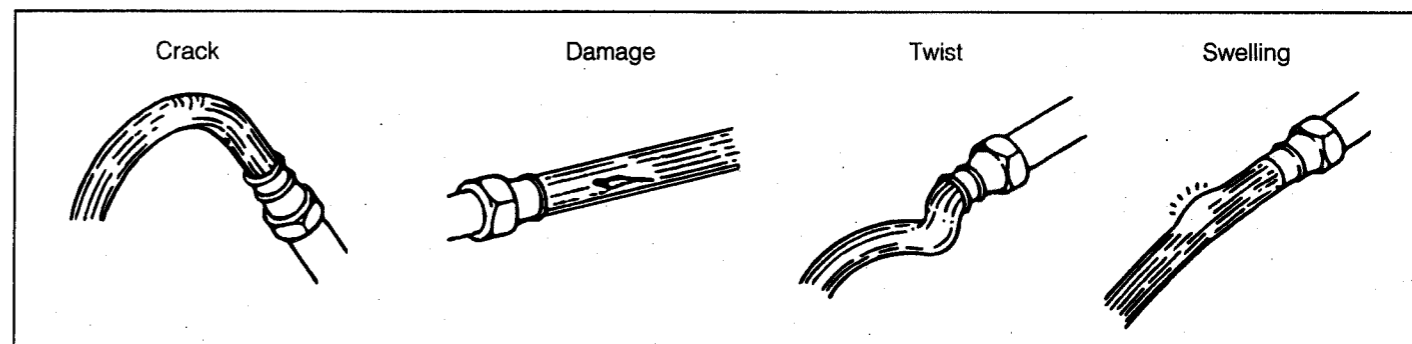

G2MA00000-00007

**HOSE CHANGE**

1. Release the brake fluid from the reservoir tank.
2. Separate the hose from the brake tube, using a brake pipe wrench.
3. Detach the clip.
4. Disconnect the hose from the shock absorber bracket.
5. Disconnect the hose from wheel cylinder (or disc brake caliper).
6. Install in the reverse order of disconnecting.

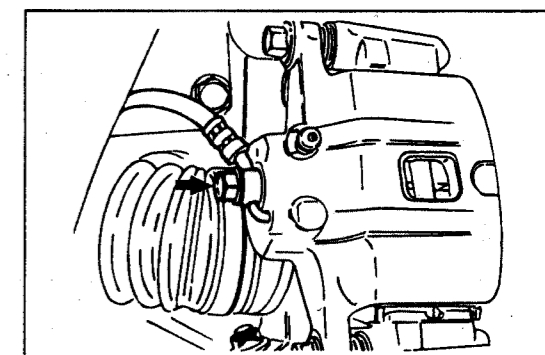

G2MA00011-00008

**NOTE:**

- When install the hose to the wheel cylinder, tighten the specified torque, new gasket interposed. (Front brake)  
Tightening Torque: 27 - 34 N·m (2.7 - 3.5 kgf·m)
- When install the brake hose to the brake tube, tighten the specified torque. (Rear brake)  
Tightening Torque: 13 - 17 N·m (1.3 - 1.8 kgf·m)

7. Perform the operation of air bleeding for the brake piping line. (See brake fluid change.)

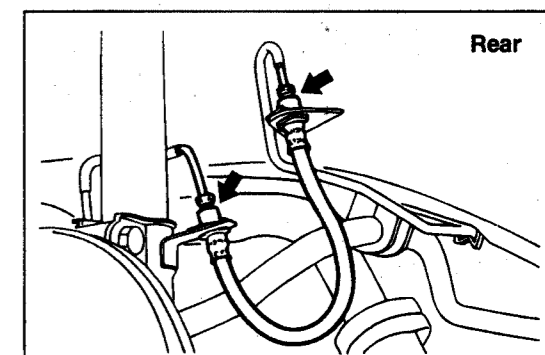

G2MA00012-00009

PARKING BRAKE LEVER

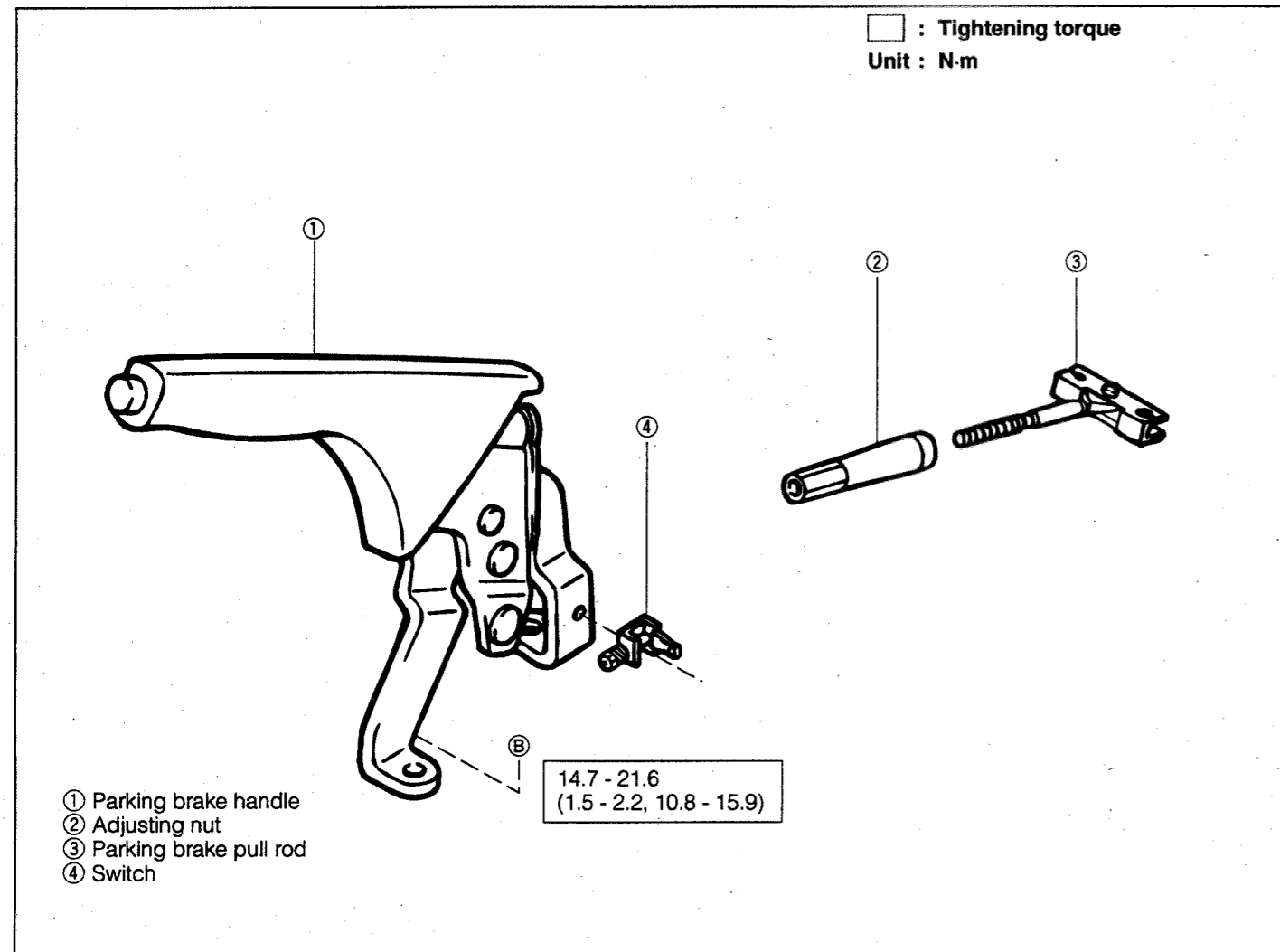

WORKING TRAVEL

1. Pull the lever with 200 N by hand.  
Specified Value: 4 - 7 notches

NOTE:

- If not specified value, adjust the adjusting nut.

2. Check the brake warning lamp for proper operation.

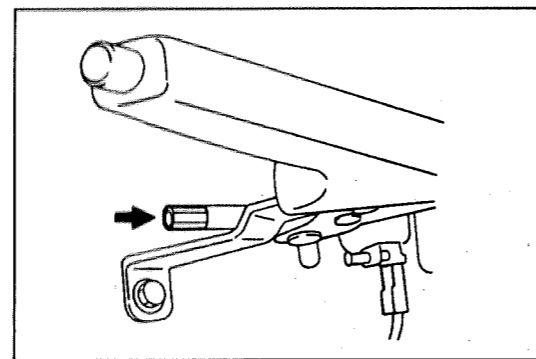

EFFECTIVENESS

1. Check to see if the vehicle can be retained in a stationary state on a dry slope with grade of 1:5 when the parking brake is applied.
2. Check that the ratchet of parking brake lever is functioning properly. Also, check the tooth shape of the ratchet for any abnormality.

G2MA00015-00000

PARKING BRAKE ROD & CABLE

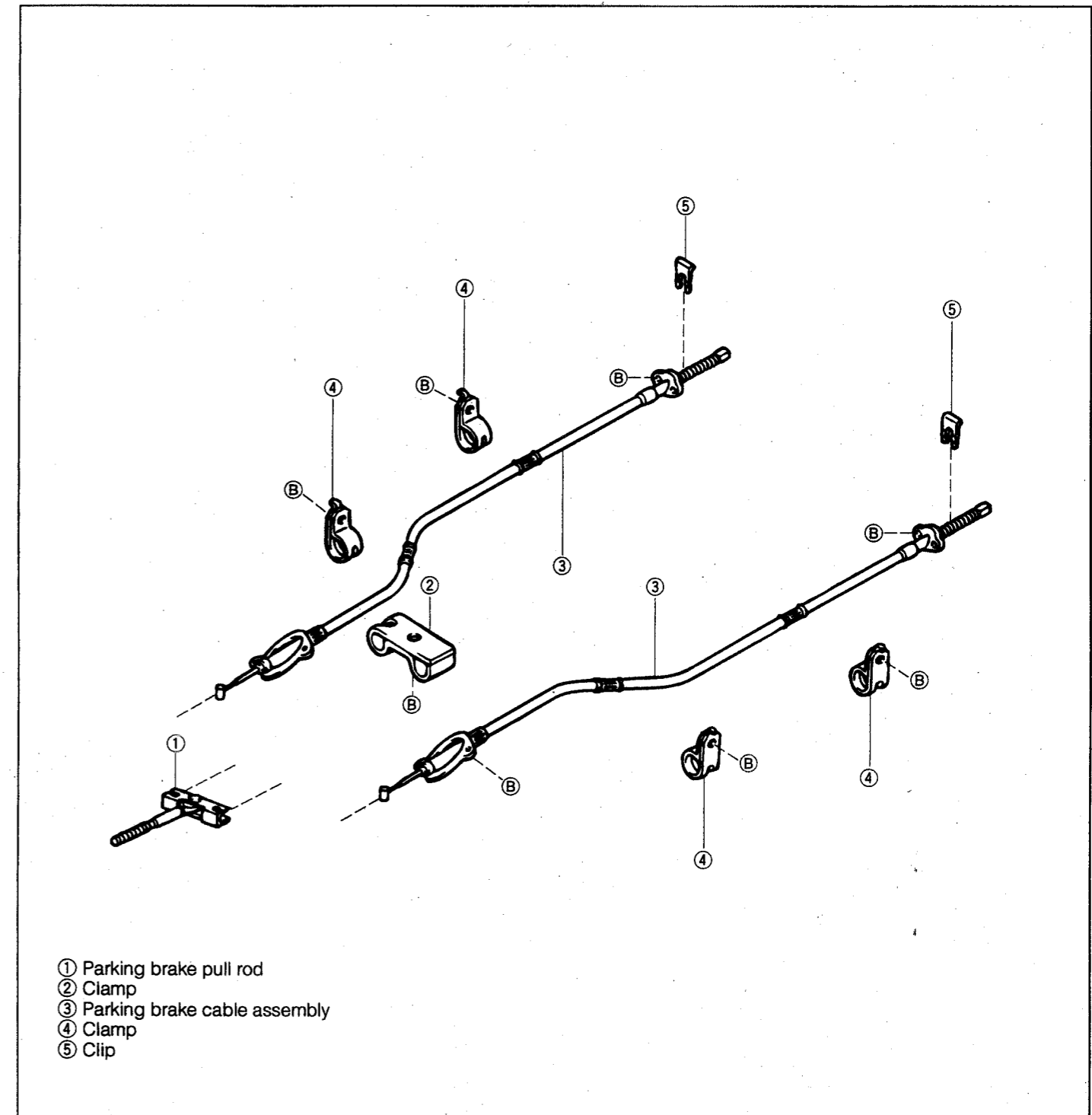

TIGHTNESS, RATTLE OR DAMAGE

1. Inspect the clamp-related parts for tightness, rattle or damage.

Tightening Torque:

4 - 7 N·m (0.4 - 0.7 kgf·m) for all bolts

2. Inspect the rod and cable for damage.

G2MA00017-00000

FRONT BRAKE (Disc brake)

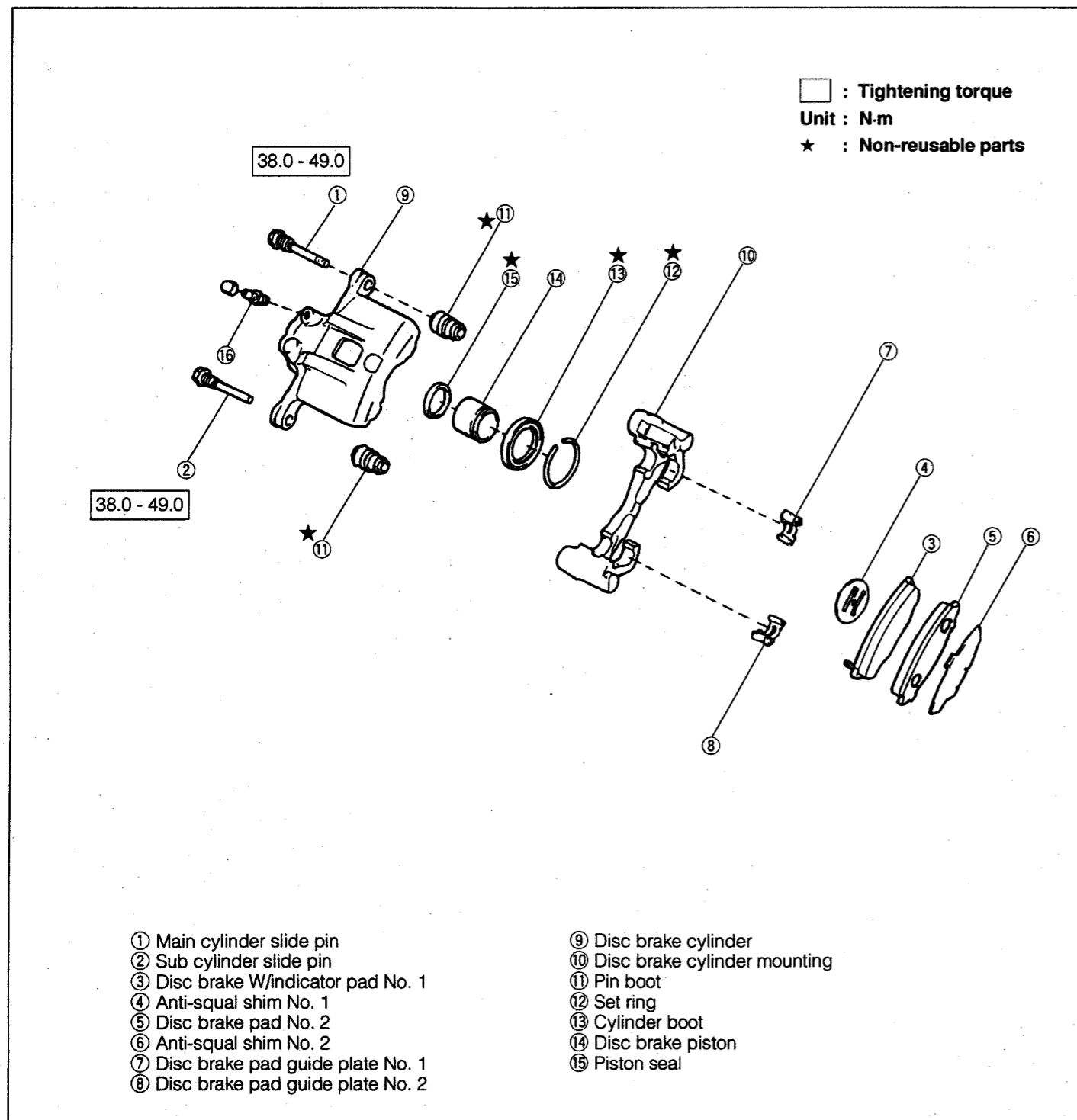

G2MA00018-00013

INSPECTION

1. Jack up the vehicle with safety stands. Remove the wheel.
2. Inspect the pad for damage and uneven wear.
3. Inspect the disk caliper for damage and malfunction.

NOTE:

- Any defective parts must be replaced.

G2MA00019-00000

DISC BRAKE PAD WEAR

1. Inspect the brake pad thickness through the inspection hole **A** provided in the caliper.  
Specified Thickness: 10 mm  
Minimum Limit : 1 mm

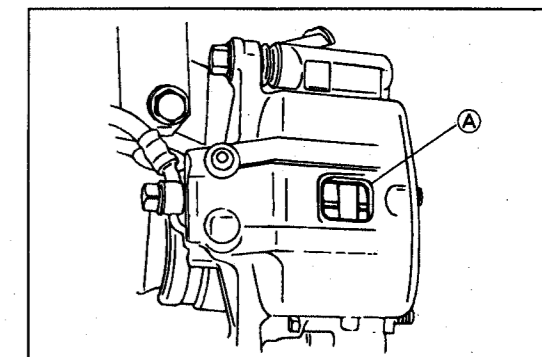

G2MA00020-00014

CUP AND DUST SEAL REPLACEMENT

1. Disconnect the flexible hose from the disc brake caliper.
2. Remove the disc brake cylinder by removing the two attaching bolts.
3. Detach the disc brake pad.  
NOTE:
  - Cut off the brake fluid leakage at the point of flexible hose end by means of suitable stopper.

G2MA00021-00000

4. Detach the cylinder boot set ring and cylinder boot, using a screwdriver.

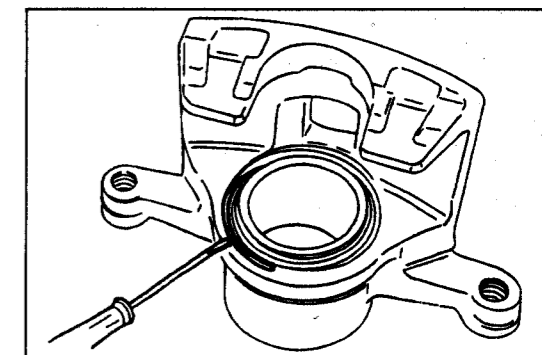

G2MA00022-00015

5. With a wooden piece or a cloth placed at the end of the disc cylinder, as indicated in the illustration. Drive out the piston by applying compressed air.

CAUTION:

- Special caution must be exercised so that no brake fluid may be splashed. Also, be very careful not to allow your finger be pinched.

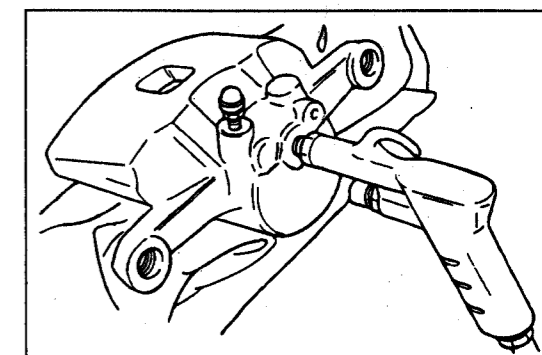

G2MA00023-00016

6. Detach the piston seal, using a screwdriver.

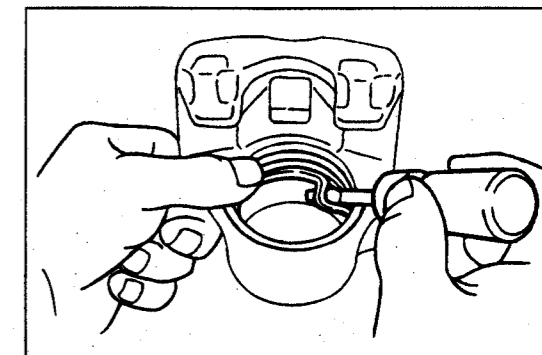

G2MA00024-00017

7. Prepare the following new parts.

- Piston seal
- Cylinder boot
- Set ring
- Bush dust boot

**NOTE:**

- Also, replace any damaged parts.
- Apply grease to those points indicated in the illustration.  
Specified Grease: Brake rubber grease.

8. Assemble the piston seal in the disk brake caliper.

9. Insert the piston into the caliper, making sure that the piston is not tilted during the installation.

10. Assemble the cylinder boot in the caliper.

**NOTE:**

- Make sure that the boot is fitted securely in the groove.

11. Assemble the cylinder boot set ring, making sure not to scratch the boot.

12. Install the anti-squall shim No. 1 ③ to the cylinder. Install the anti-squall shim No. 2 ⑤ to the disk brake pad outer.

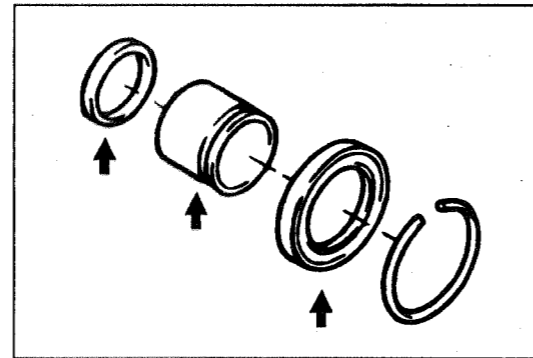

G2MA00025-00018

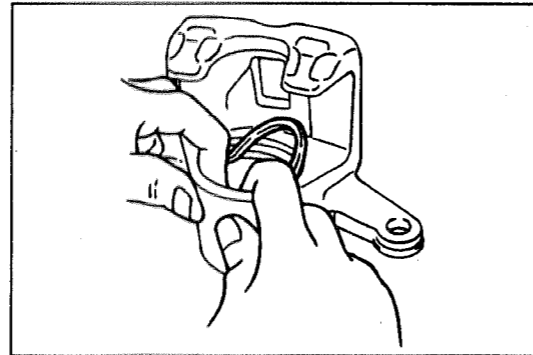

G2MA00026-00019

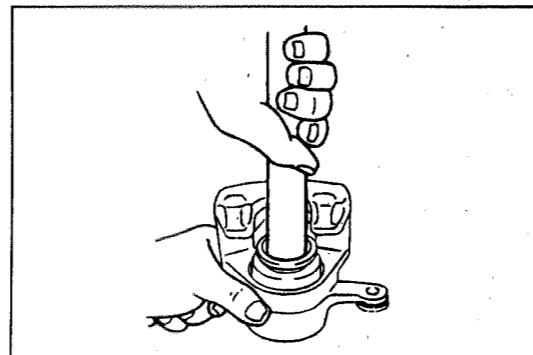

G2MA00027-00020

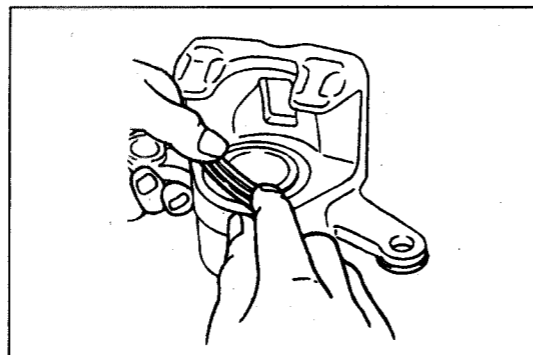

G2MA00028-00021

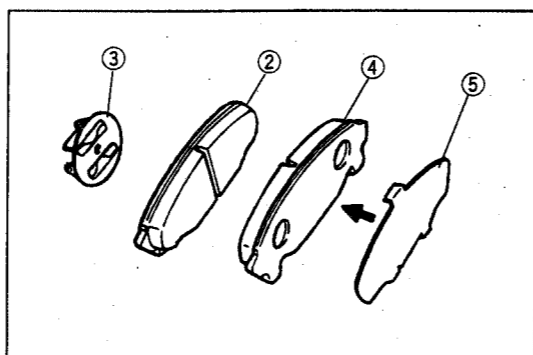

G2MA00029-00022

13. Install the disc brake pad guide plate on the knuckle. Install the brake pad in the caliper. Install the disc brake pad to the disc brake cylinder mounting. Then, install the disc brake cylinder to the disc brake cylinder mounting.

Tightening Torque: 38 - 49 N·m (3.8 - 5.0 kgf·m)

14. Install the flexible hose.

Tightening Torque: 27 - 34 N·m (2.7 - 3.5 kgf·m)

15. Perform air bleeding for the brake system.

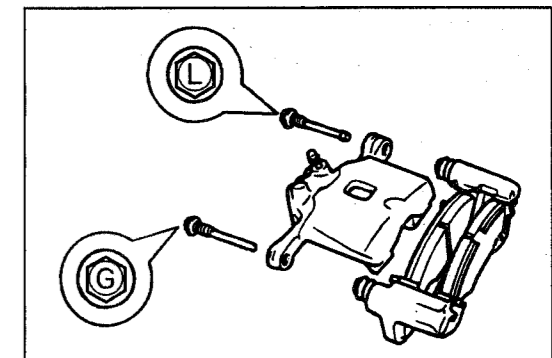

G2MA00030-00023

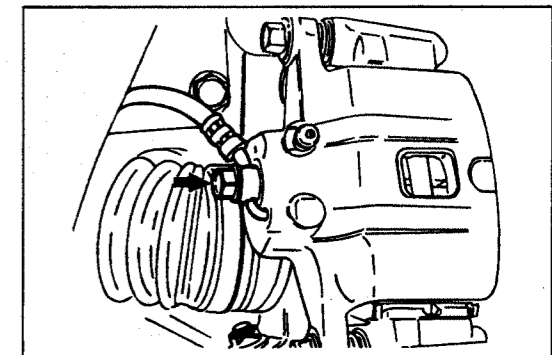

G2MA00031-00008

**DISC TO PAD CLEARANCE**

1. Depress the brake pedal more than 20 times.
2. Check to see if the brake disc can be rotated smoothly.
3. Ensure that no abnormal sound is emitted when the wheel is rotated.

G2MA00032-00000

**FLUID LEAKAGE**

1. Inspect the fluid leakage from the disk brake cylinder portion.
2. Inspect the fluid leakage from the brake hose connecting portion between the cylinder and hose.

G2MA00033-00000

## REAR DRUM BRAKE

### COMPONENT

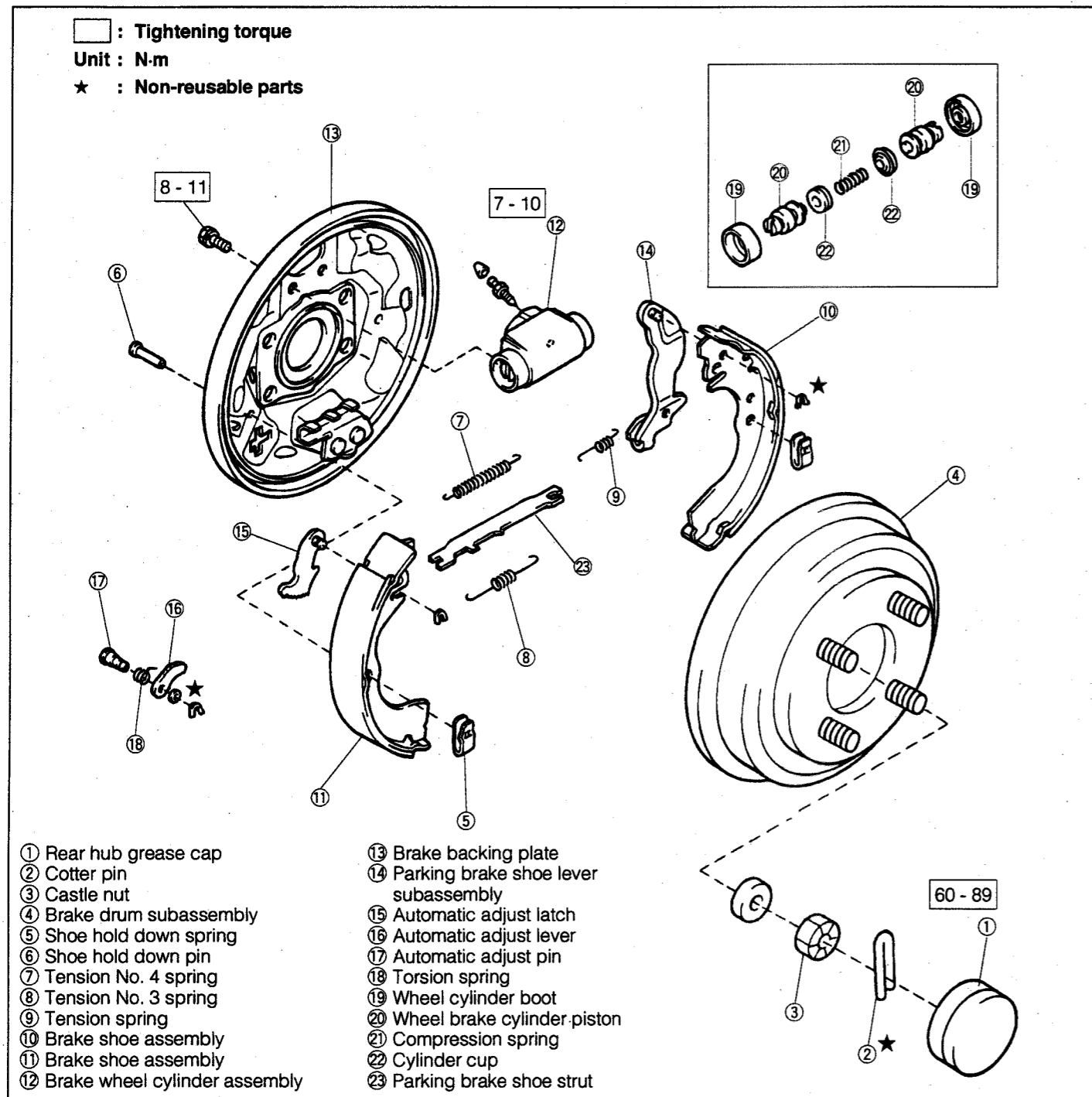

G2MA0034-00025

### INSPECTION

- Remove the gum plug at the inspection hole provided on the backing plate.
- Inspect the brake shoe lining wear through the inspection hole.

Allowable Limit: 1 mm

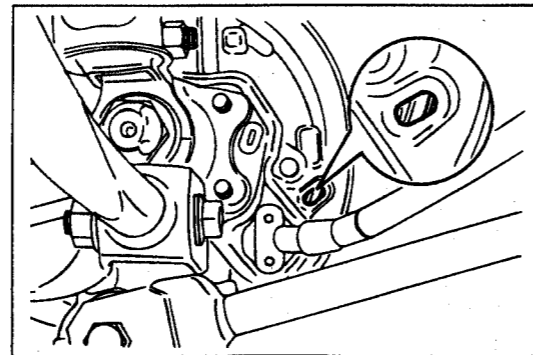

G2MA0035-00026

### BRAKE DRUM AND LINING WEAR

- Remove the grease cap, cotter pin, lock nut and plate washer. Then, remove the brake drum, using the SST.  
SST: 09510-87301-000
- Inspect the brake drum diameter.  
Specified Diameter: 180 mm  
Allowable Limit : 181 mm
- Inspect the brake lining thickness.  
Specified Thickness: 4.0 mm  
Allowable Limit : 1 mm

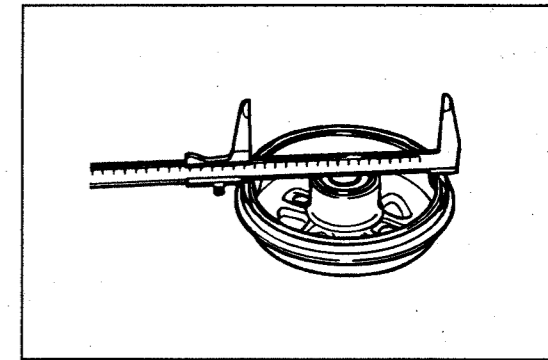

G2MA0036-00027

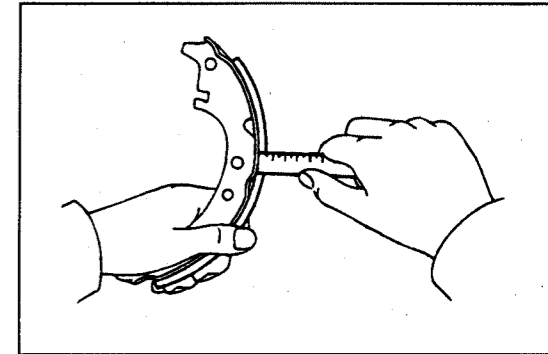

G2MA0037-00028

### WHEEL CYLINDER REPLACEMENT

- Remove the tension springs, using the SST.  
SST: 09703-30010-000
- Disconnect the brake tube from the wheel cylinder, using the brake pipe wrench.
- Remove the attaching bolts of the wheel cylinder. Proceed to remove the wheel cylinder from the backing plate.
- Replace the following parts.
  - Wheel cylinder boot
  - Wheel cylinder piston cups
  - Compression spring
- Assemble the cup on the wheel cylinder piston.  
NOTE:
  - Be sure to install the cup in the correct direction.
  - Apply brake rubber grease to the piston cup.
- Install the two pistons and compression spring to the wheel cylinder.
- Assemble the two wheel cylinder boots.

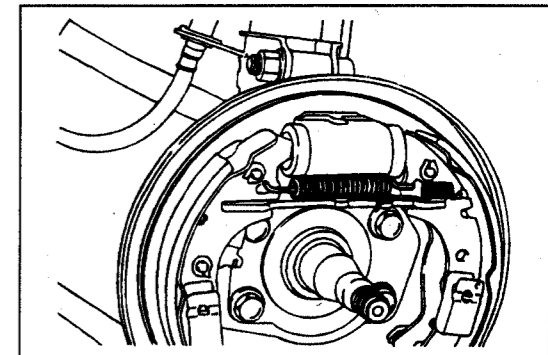

G2MA0038-00029

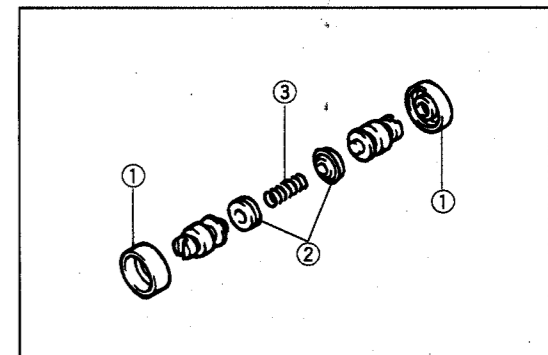

G2MA0039-00030

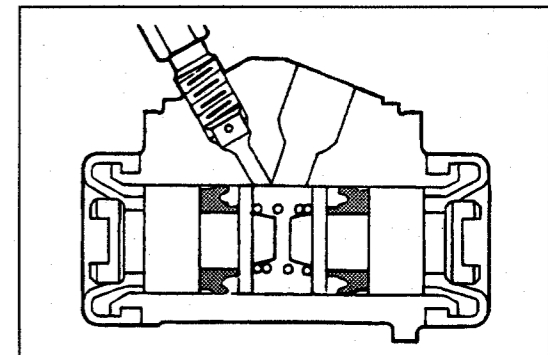

G2MA0040-00031



8. Install the wheel cylinder to the backing plate.  
Tightening Torque: 8 - 11 N-m (0.8 - 1.2 kgf-m)

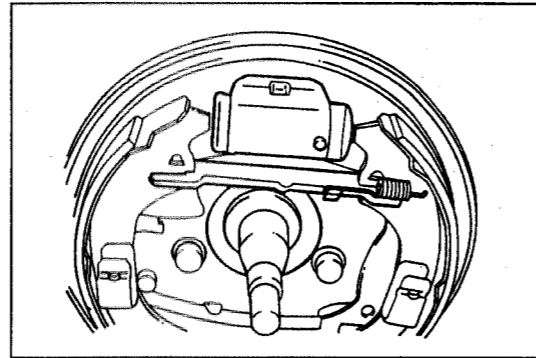

G2MA00041-00032

9. Install the brake pipe to the wheel cylinder temporarily by hand. Then, tighten the nut of brake pipe, using the brake pipe wrench.  
Tightening Torque: 13 - 17 N-m (1.3 - 1.8 kgf-m)

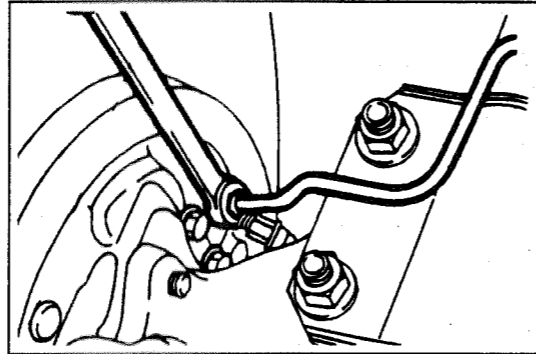

G2MA00042-00033

10. Install the tension spring.  
NOTE:  
• Be careful not to damage the wheel cylinder boot during the installation.

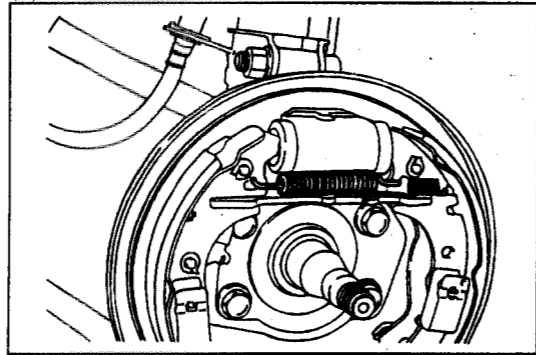

G2MA00043-00029

11. Install the brake drum subassembly, then tighten the lock nut.  
Tightening Torque: 60 - 89 N-m (6.1 - 9.1 kgf-m)

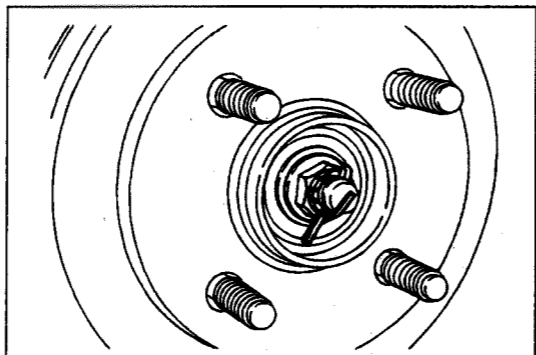

G2MA00044-00035

13. Perform air bleeding for the brakes.  
14. Depress the brake pedal. Ensure that the automatic adjusting mechanism emit operating sound. Continue this operation, until you no longer hear any operating sound.  
15. Adjust the working travel of the parking brake lever.

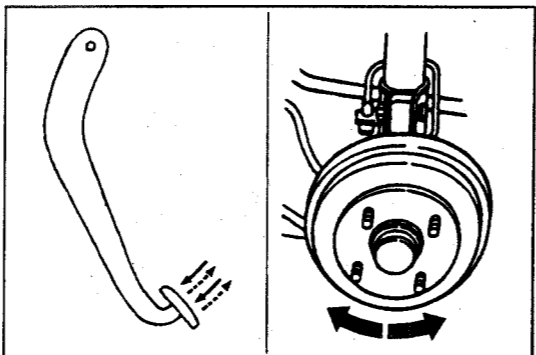

G2MA00045-00036

**FLUID LEAKAGE**  
Inspect the fluid leakage from the brake system.

**BRAKE BOOSTER COMPONENTS**

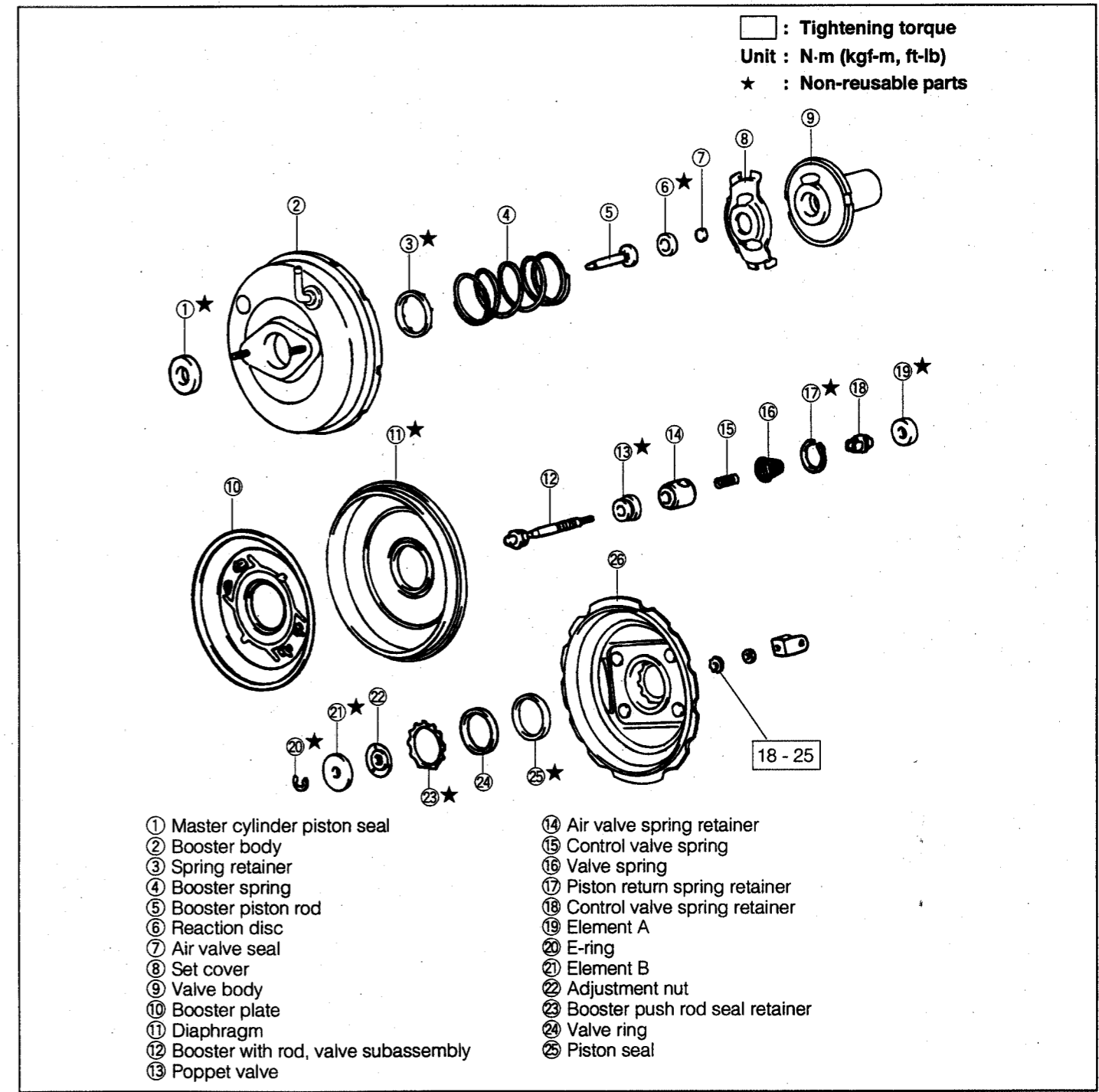

G2MA00046-00037

**FUNCTION CHECK**  
With the engine stopped, depress the brake pedal several times, applying the same force at each brake application. Ensure that the brake pedal height will not vary at each brake application. Then, start the engine while depressing the brake pedal. If the brake pedal moves in slightly, it indicates that the booster is functioning properly.

G2MA00047-00000

**BRAKE BOOSTER REMOVAL**

1. Disconnect the connector of the brake fluid level switch.
2. Drain the brake fluid.
3. Disconnect the brake pipes from the master cylinder.
4. Remove the master cylinder and gasket.
5. Disconnect the vacuum hose.

**NOTE:**

- If the brake fluid is spilled inadvertently over the paint-finish surface of the vehicle, quickly wipe off the brake fluid.

6. Remove the ignition coil. (For LHD vehicle)
7. Remove the air cleaner. (For LHD vehicle)

8. Removal the clutch cable support bracket. (For LHD vehicle)
  - (1) Remove the battery and the engine coolant reservoir tank.
  - (2) Disconnect the clutch cable from the transmission side and the clutch pedal.

- (3) Remove the clutch cable support bracket.

9. Remove the instrument finish lower panel.

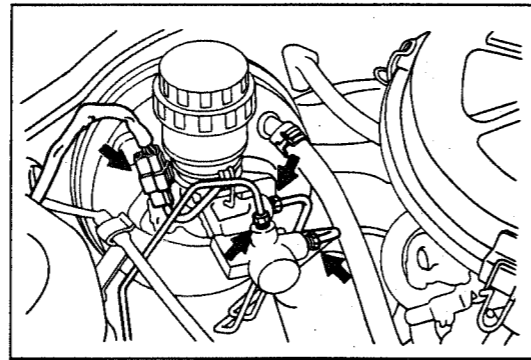

G2MA00048-00038

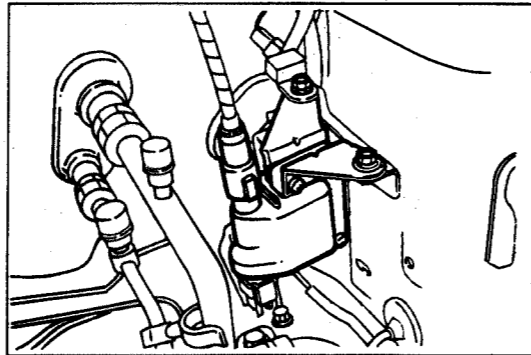

G2MA00049-00200

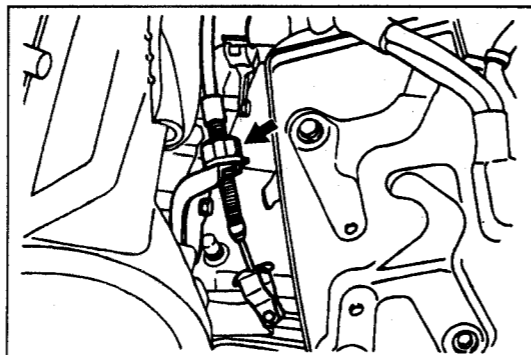

G2MA00050-00039

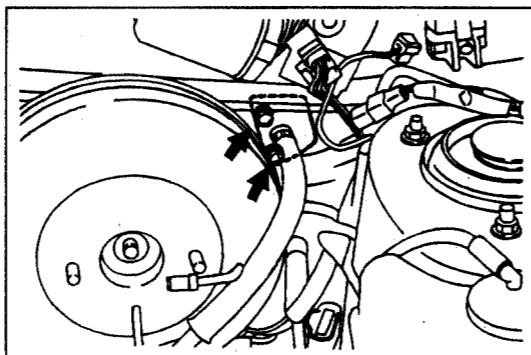

G2MA00051-00040

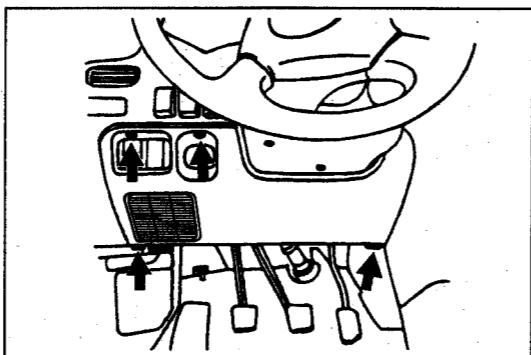

G2MA00052-00041

10. Disconnect the connector for the multi-use lever switch and key switch.
11. Remove the steering column assembly from the reinforcement, by removing the two nuts and four bolts.

12. Remove the clip and the with-hole pin at the brake pedal. Separate the master cylinder push rod clevis and from the brake pedal.
13. Remove the brake booster assembly and gasket from the vehicle, by removing the four nuts.

**REPLACEMENT OF RUBBER PARTS**

1. Remove the booster push rod clevis and lock nut.
2. Separate the booster housing from the booster body as follows:
  - (1) Secure the brake booster on the following SST. SST: 09753-87701-000

- (2) Put mate marks on the booster body and booster housing.

**NOTE:**

- Be certain to evenly tighten the SST nuts at the right and left sides. Also, be very careful not to tighten the SST nuts excessively.

- (3) Turn the SST screw clockwise so as to disengage the booster housing from the booster body.

- (4) Remove the brake booster from the SST.

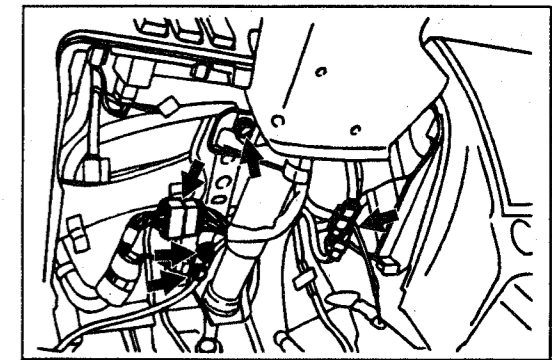

G2MA00053-00042

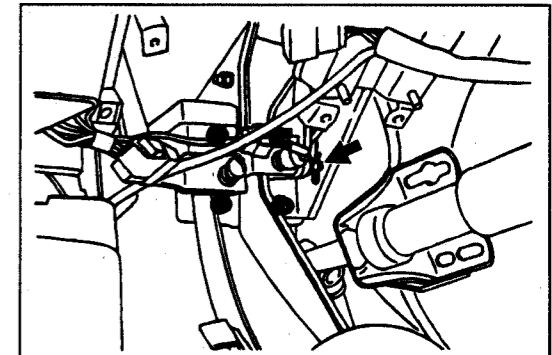

G2MA00054-00043

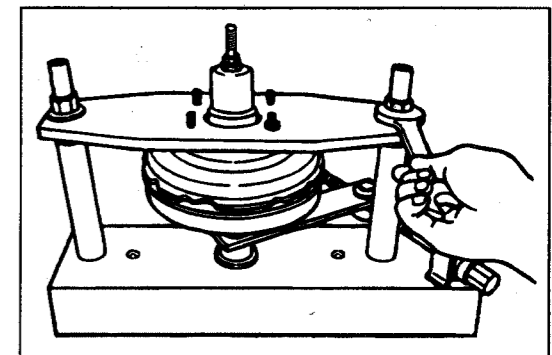

G2MA00055-00044

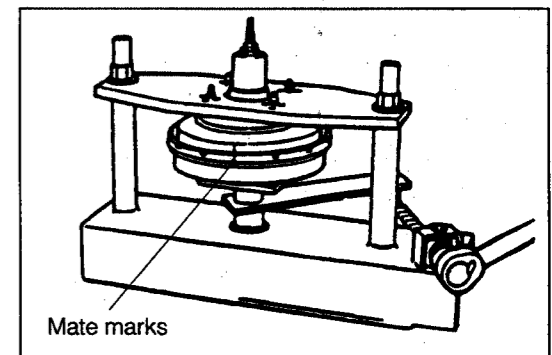

Mate marks

G2MA00056-00045

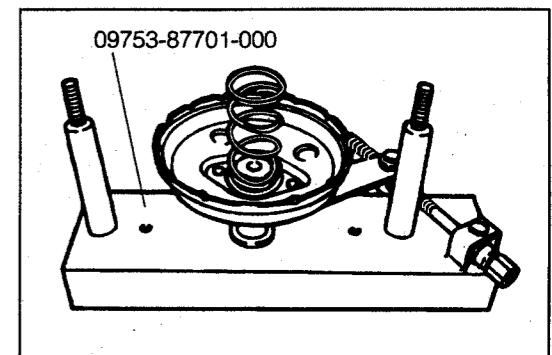

09753-87701-000

G2MA00057-00046

3. Disassembly of booster

- (1) Remove the booster spring and spring retainer.
- (2) Disassembly of set cover as following
  - (a) Slide the claw section of the set cover using a screwdriver.
  - (b) Disassemble the set cover from booster plate.

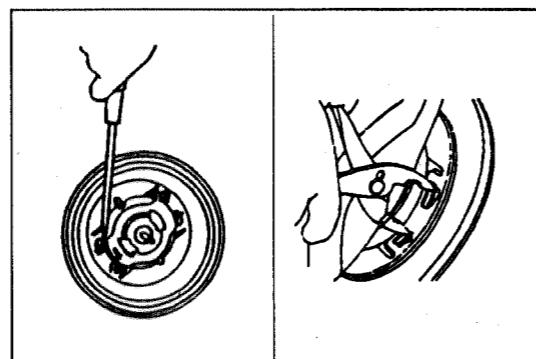

G2MA00058-00047

(3) Removal of following parts

- (a) Booster piston rod
- (b) reaction disc
- (c) Air valve seal
- (d) Valve body assembly
- (e) Booster plate
- (f) Diaphragm

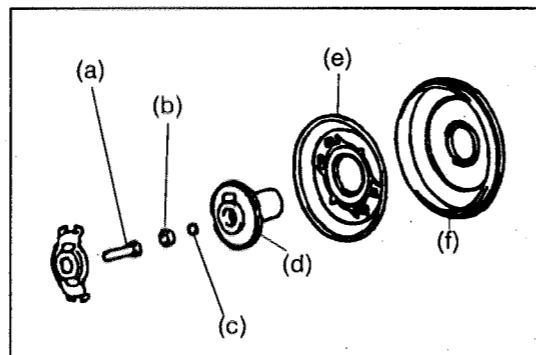

G2MA00059-00048

(4) Removal of following parts

- (a) Lock nut
- (b) Adjusting nut
- (c) Element B

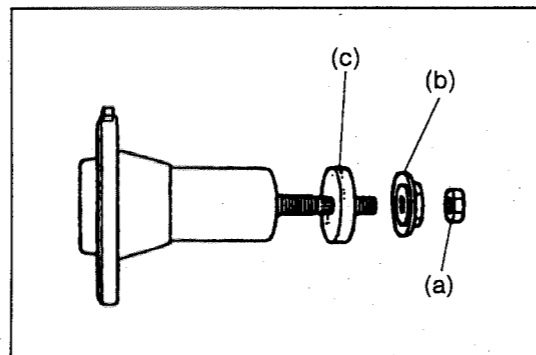

G2MA00060-00049

(5) Disassembly of air valve spring retainer in conjunction with the following parts from the valve body as following.

NOTE:

- Remove the piston return spring retainer. Then, push the valve body in combination with the booster piston rod by hands as indicated in the illustration.

- (a) Piston return spring retainer
- (b) E-ring
- (c) Element A
- (d) Control valve spring retainer
- (e) Valve spring
- (f) Control valve spring
- (g) Air valve spring retainer
- (h) Poppet valve
- (i) Booster valve subassembly with rod

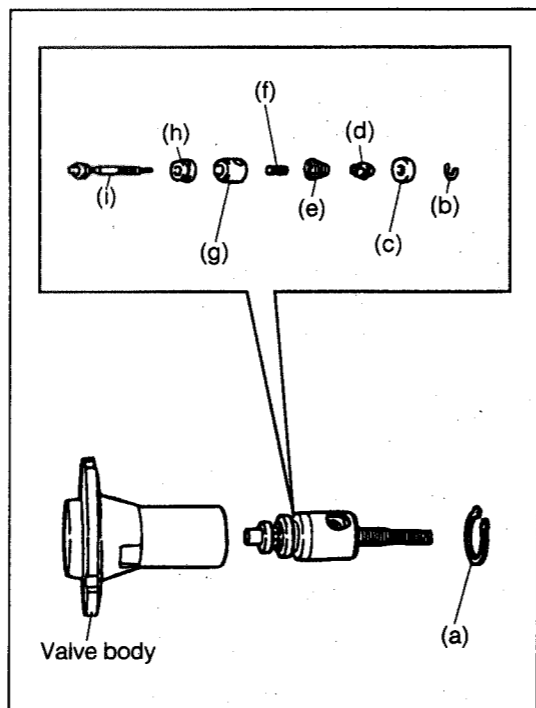

G2MA00061-00050

4. Prepare following new parts.

- Master cylinder piston seal
- Spring retainer
- Reaction disc
- Diaphragm
- Poppet valve
- Element A
- Piston return spring retainer
- E-ring
- Element B
- Booster push rod seal retainer
- Piston seal

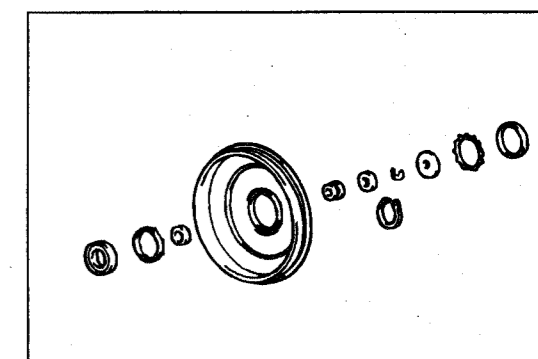

G2MA00062-00051

5. Assembly of air valve spring retainer

- (1) Assemble a new poppet valve and the valve spring retainer.
- (2) Install the booster valve subassembly with rod into the valve spring retainer.
- (3) Install the control valve spring and valve spring into the rod.

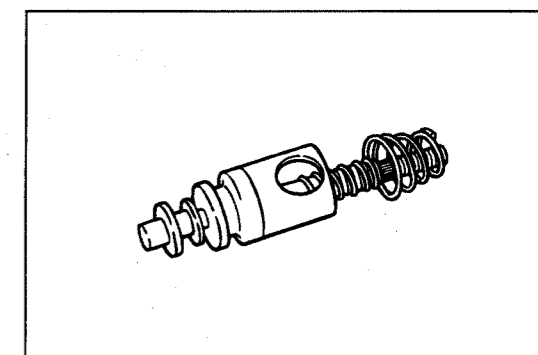

G2MA00063-00052

- (4) Assemble a new element A and the new control valve spring retainer.
- (5) Install them into the rod.
- (6) Attach the new E-ring in place of the rod while pushing the control valve spring retainer with finger. Then, install the E-ring with a pliers.

NOTE:

- Make sure to installation direction of the control valve spring retainer that its long side faces spring side and short faces element side.

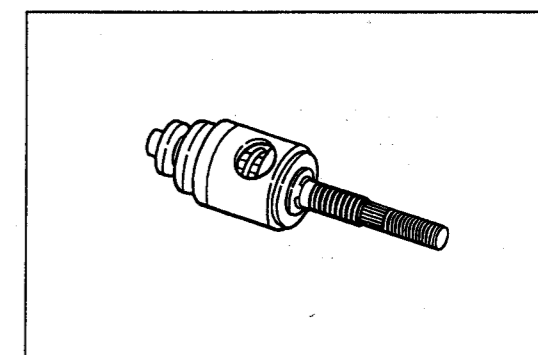

G2MA00064-00053

6. Assembly of valve body

- (1) Apply silicon grease around the poppet valve. Then, install them into the valve body.
- (2) Place the piston return spring retainer into the valve body with a snap ring pliers.

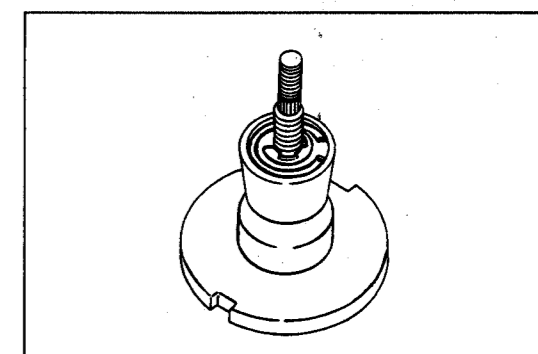

G2MA00065-00054

- (3) Install a new element ③, adjusting nut ② and lock nut ① into the rod as temporarily.

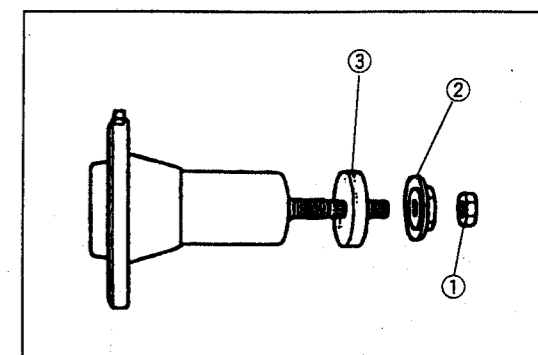

G2MA00066-00055

7. Apply silicon grease to the inner and outer periphery of the piston seal 25 as well as to the inside of the groove. Insert the piston seal into the booster housing. also, insert the valve ring 24. Secure them with the booster push rod seal retainer 23.

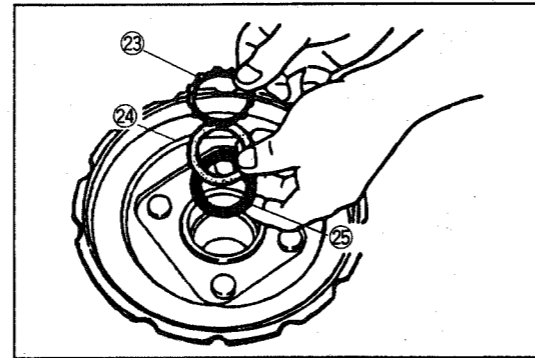

G2MA00067-00056

8. Assemble the new diaphragm 11 and booster plate 10. Then, attach them into the booster housing.
9. Apply silicone grease to the outer periphery of the valve body. Then, assemble them into the booster housing.

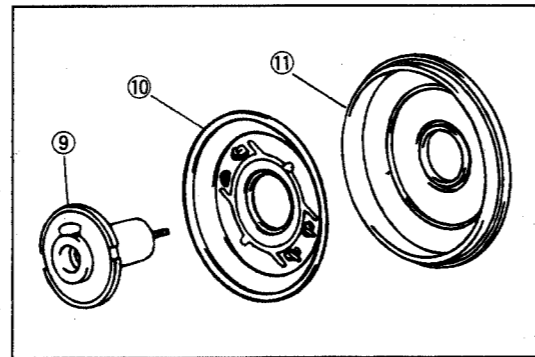

G2MA00068-00057

10. Installation of following parts in the valve body.

- (a) Reaction plate 7
- (b) New reaction disc 6
- (c) Booster piston rod 5

NOTE:

- Install the reaction plate in such a direction that its flat side faces upward.
- Apply silicone grease to the reaction disc.

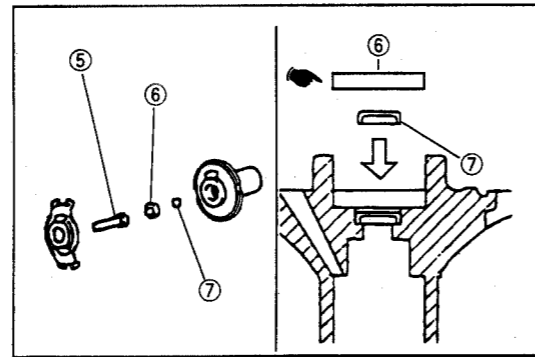

G2MA00069-00058

11. Installation of set cover 1 as follows

- (1) Temporarily install the set cover on the booster plate.

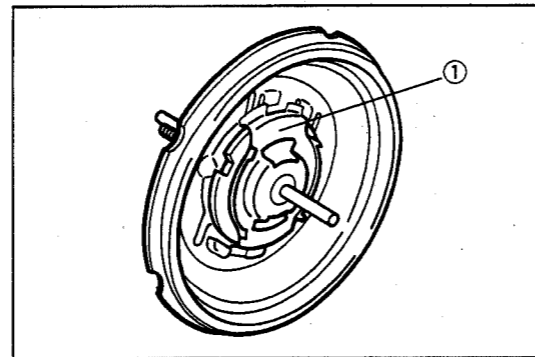

G2MA00070-00059

- (2) Assemble the set cover by pinching the joint section of the booster plate with the claw section of the set cover, using pliers.
- (3) Slide the claw section of the set cover using a screwdriver, until it touched the stopper.

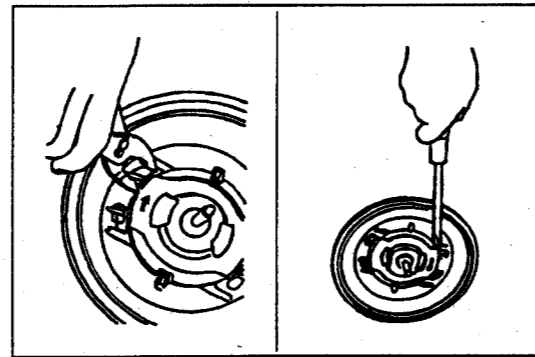

G2MA00071-00060

12. Assemble the booster body and booster housing as follows:

- (1) Place the booster housing in the SST. Place the booster body, spring retainer and booster piston return spring in the following SST. SST: 09753-87701-000

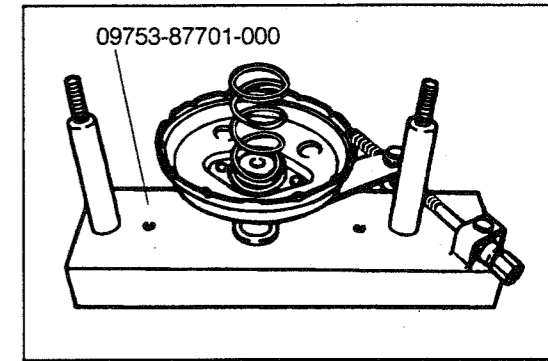

G2MA00072-00046

- (2) Place the new spring retainer and booster piston return spring on the booster body.

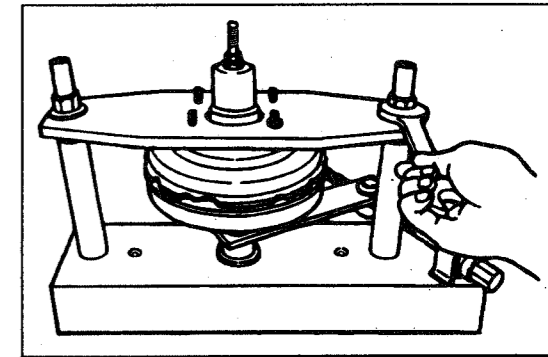

G2MA00073-00044

- (3) Align the cut-out section of the booster body with projected section. Join the booster body with the booster housing in the SST and tighten the SST nuts until booster housing and booster body will be contacted.

NOTE:

- Be certain to evenly tighten the SST nuts at the right and left sides. Also, be very careful not to tighten the SST nuts excessively.
- Furthermore, care must be exercised to ensure that the diaphragm will not be pinched.

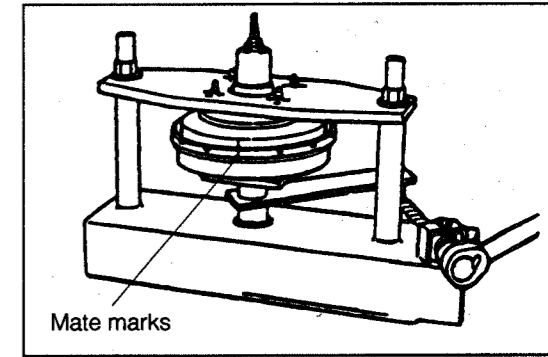

G2MA00074-00045

- (4) Turn the SST screw counterclockwise so that the mating marks may be lined up.

NOTE:

- If the force required for turning is great, apply a small amount of silicon grease to the portion where the booster body is making contact with the booster housing.

- (5) Remove the brake booster from the SST.

13. Install the master cylinder piston seal in the brake booster.
14. Temporarily install the master cylinder push rod clevis and nut.

G2MA00075-00000

**BRAKE BOOSTER PUSH ROD CLEARANCE ADJUSTMENT**

1. Set the SST in such a way that the SST rod makes a light contact with the piston of the master cylinder by turning the SST rod, as indicated in right figure.  
SST: 09737-87002-000

**NOTE:**

- Be sure to carry out this adjustment with the gasket attached in position of the master cylinder.

2. Turn over the SST and set the SST on the booster as indicated in the illustration.
3. Apply a vacuum of 500 mmHg to the booster housing, using a MityVac.
4. Measure the piston rod height by turning the SST rod so that it may make a contact with the booster piston rod and SST rod.

**NOTE:**

- The SST rod employs a screw of 1 mm pitch. Therefore, one turn of the rod makes a movement of 1 mm.
- When the booster piston rod makes an excessive contact with the SST rod, back off the SST itself.

5. Adjust the height of the booster piston rod by turning the adjusting nut provided at the booster valve with rod, until the SST rod and booster piston rod will contact so that the clearance between the booster piston rod and the master cylinder piston may become the specified value. Then, tighten the lock nut.

Specified Value: 0.1 - 0.5 mm  
Tightening Torque: 18 - 25 N·m

**NOTE:**

- The SST 09737-87002-000 has been newly adopted. The dimension of the SST rod is 0.2 mm longer than the SST leg. Therefore, under the condition above, the clearance between the master cylinder piston and the booster piston rod will become the specified clearance of 0.2 mm when the SST is set and the clearance becomes zero.

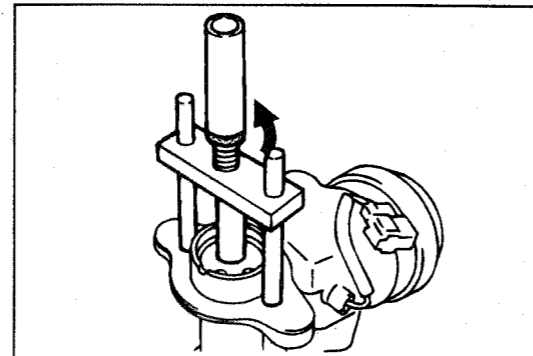

G2MA00076-00064

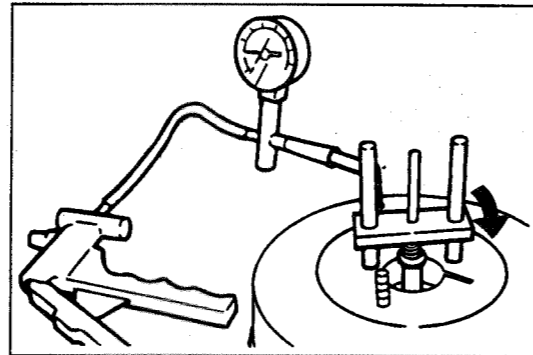

G2MA00077-00065

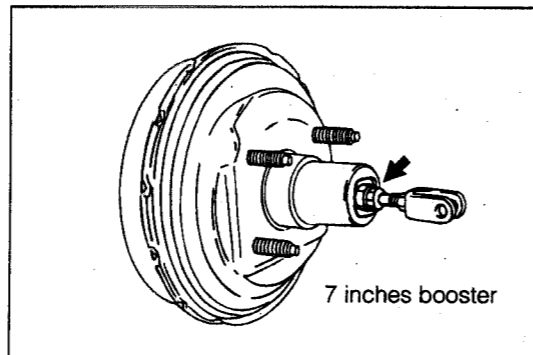

G2MA00078-00066

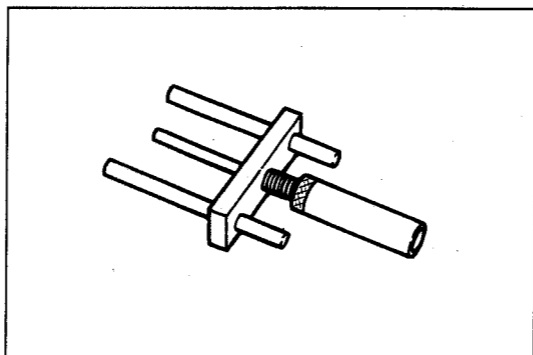

G2MA00079-00067

**BRAKE BOOSTER INSTALLATION**

1. Install the brake booster in the engine compartment with a new gasket interposed between booster and the vehicle body, using the four nuts.  
Tightening Torque: 10 - 15 N·m (1.0 - 1.6 kgf·m)

2. Install the clip and the with-hole pin at the brake pedal.

3. Install the steering column assembly to the reinforcement.  
Tightening Torque

Bolt: 15 - 21 N·m (1.5 - 2.2 kgf·m)  
Nut: 10 - 15 N·m (1.0 - 1.6 kgf·m)

4. Connect the connector for the multi-use lever switch and key switch.
5. Install the instrument finish lower panel.

6. Install the clutch cable. (For LHD vehicle)  
Adjust the clutch pedal free play and reserve travel.
7. Install the air cleaner and the ignition coil. (For LHD vehicle)
8. Connect the new vacuum hose.

9. Install the master cylinder with a new gasket interposed.  
Tightening Torque: 12.7 N·m (1.3 kgf·m)

10. Connect the brake pipes to the master cylinder.  
Tightening Torque: 13 - 17 N·m (1.3 - 1.8 kgf·m)

11. Connect the terminal of the brake fluid level switch.
12. Perform the air bleeding for the brake system.

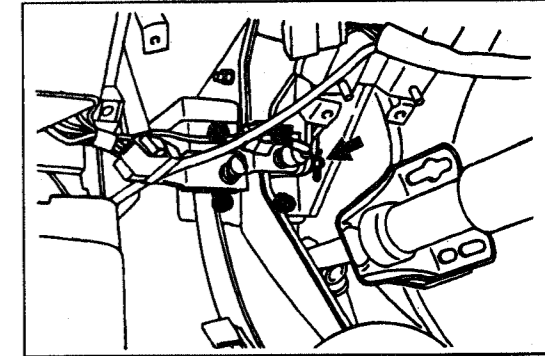

G2MA0080-00043

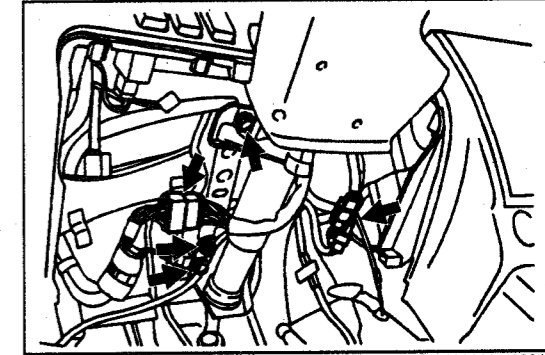

G2MA0081-00042

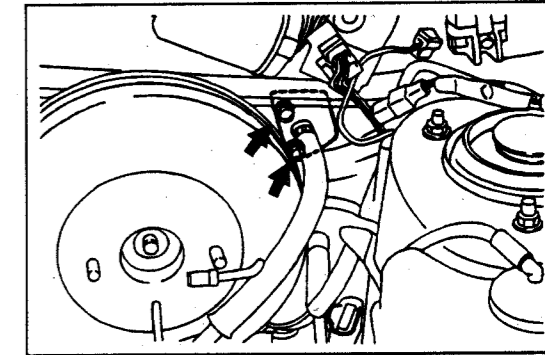

G2MA0082-00040

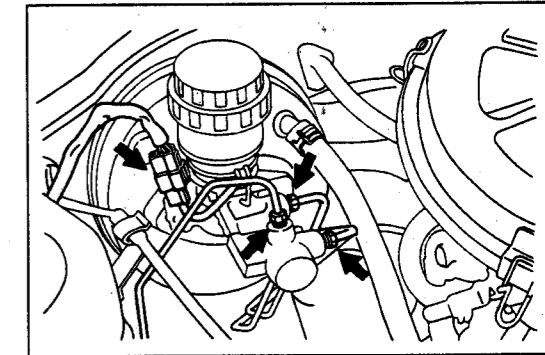

G2MA0083-00038

**BBRAKE MASTER CYLINDER COMPONENTS**

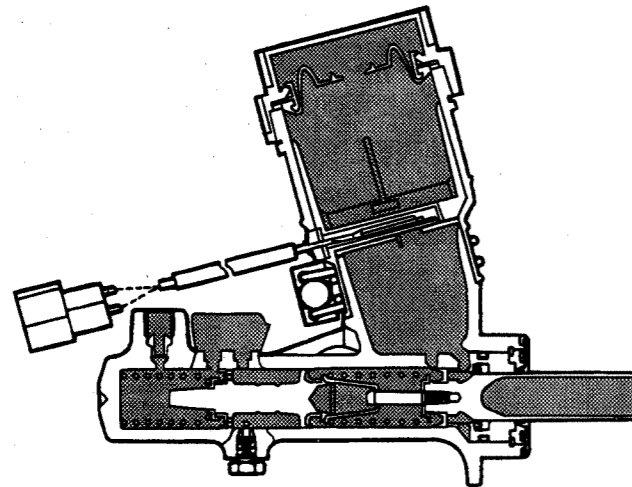
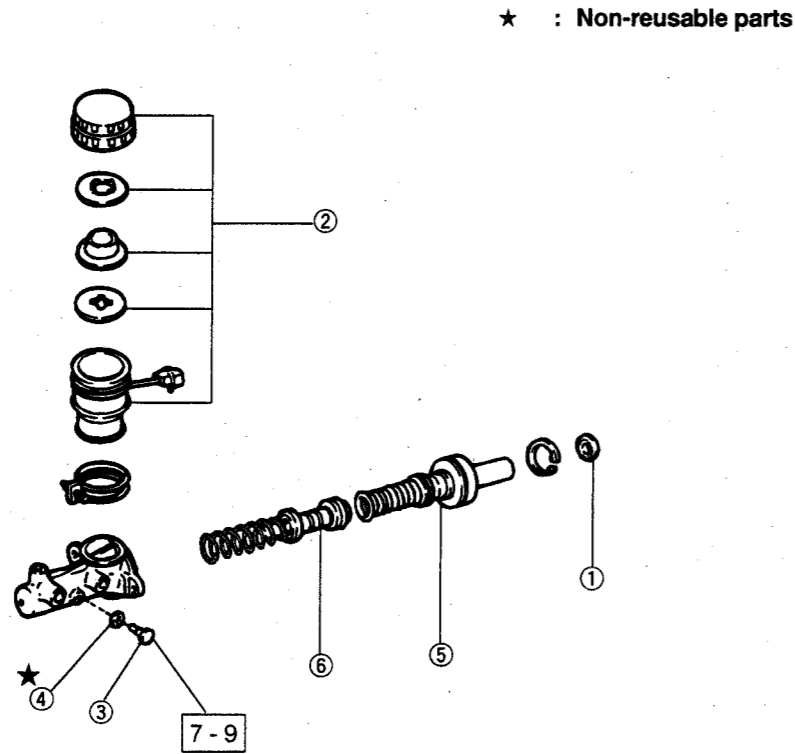

- ① Brake master cylinder piston seal
- ② Brake master cylinder reserve tank
- ③ Set bolt
- ④ Gasket
- ⑤ Brake master cylinder piston assembly No. 1
- ⑥ Brake master cylinder piston assembly No. 2

G2MA00084-00071

**REMOVAL OF BRAKE MASTER CYLINDER**

1. Disconnect the connector of the brake fluid level switch.
  2. Drain the brake fluid.
  3. Disconnect the brake pipes from the master cylinder.
  4. Remove the master cylinder and gasket.
- NOTE:
- If the brake fluid is spilled inadvertently over the paint-finish surface of the vehicle, quickly wipe off the brake fluid.
5. Remove the cylinder piston seal.

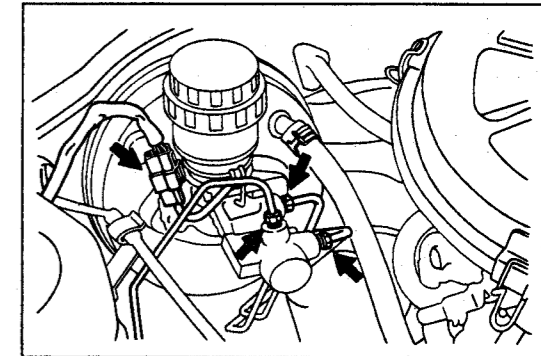

**Inner parts replacement**

1. Remove the set bolt and gasket while the pistons are being pushed fully by means of a suitable bar.
- NOTE:
- During the removal, be sure to push the piston slowly so as to prevent the brake fluid from splashing.

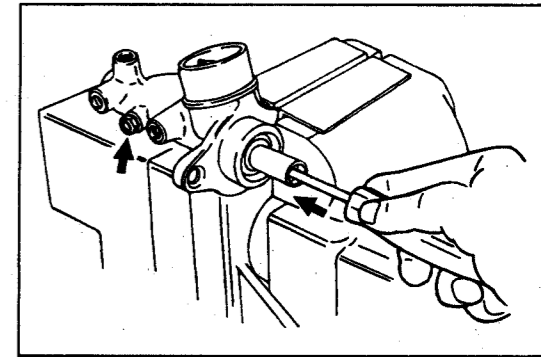

2. Using a snap ring pliers, detach the snap ring while the pistons are being pushed by means of a suitable bar.
  3. Remove the piston No. 1 from the master cylinder.
- NOTE:
- Remove the piston straight, being very careful not to scratch the cylinder bore.

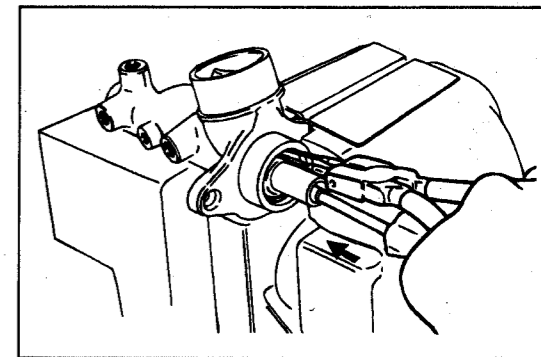

4. Remove the piston No. 2 by lightly tapping the flange surface.
- NOTE:
- Remove the piston straight, being very careful not to scratch the cylinder bore.

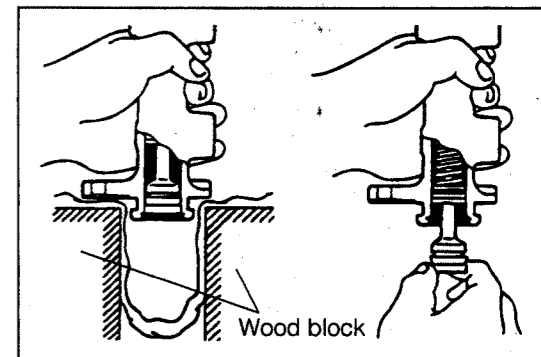

5. Prepare the following parts.
  - Brake master cylinder piston seal
  - Gasket
  - Brake master cylinder piston assembly No. 1
  - Brake master cylinder piston No. 2

- NOTE:
- Apply rubber grease to those points indicated in the illustration.

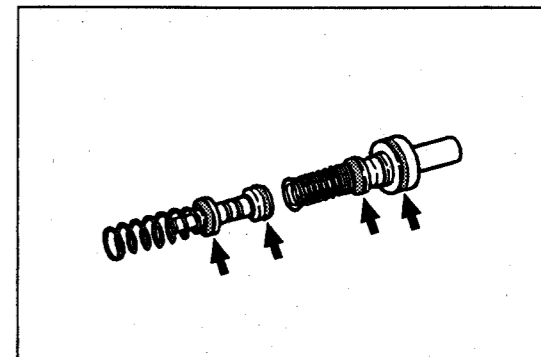

6. With the pistons in their fully pushed in state, install a new snap ring.

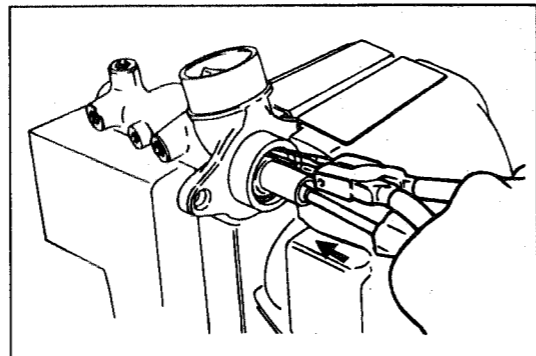

G2MA00090-00073

7. While pushing the pistons fully with a screwdriver, assemble the set bolt with a new gasket.

Tightening Torque: 7 - 11 N·m (70 - 110 kgf·cm)

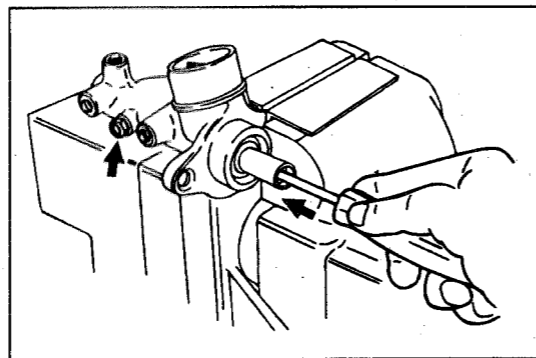

G2MA00091-00072

8. Install the master cylinder piston seal.  
 9. Check and adjust the brake booster push rod clearance.  
 10. Install the master cylinder to the brake booster with a new gasket.

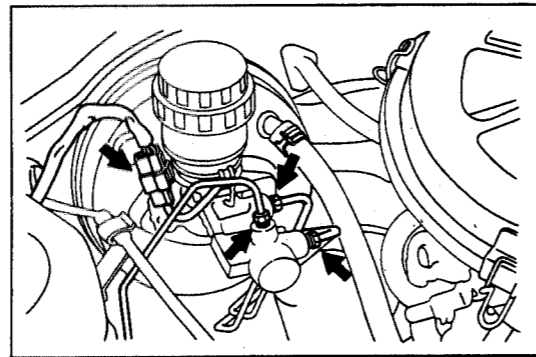

G2MA00092-00038

11. Connect the brake pipes to the master cylinder.  
 Tightening Torque: 13 - 17 N·m (1.3 - 1.8 kgf·m)

12. Connect the terminal of the brake fluid level switch.  
 13. Perform the air bleeding for the brake system.

G2MA00093-00000

PROPORTIONING VALVE

□ : Tightening torque  
 Unit : N·m

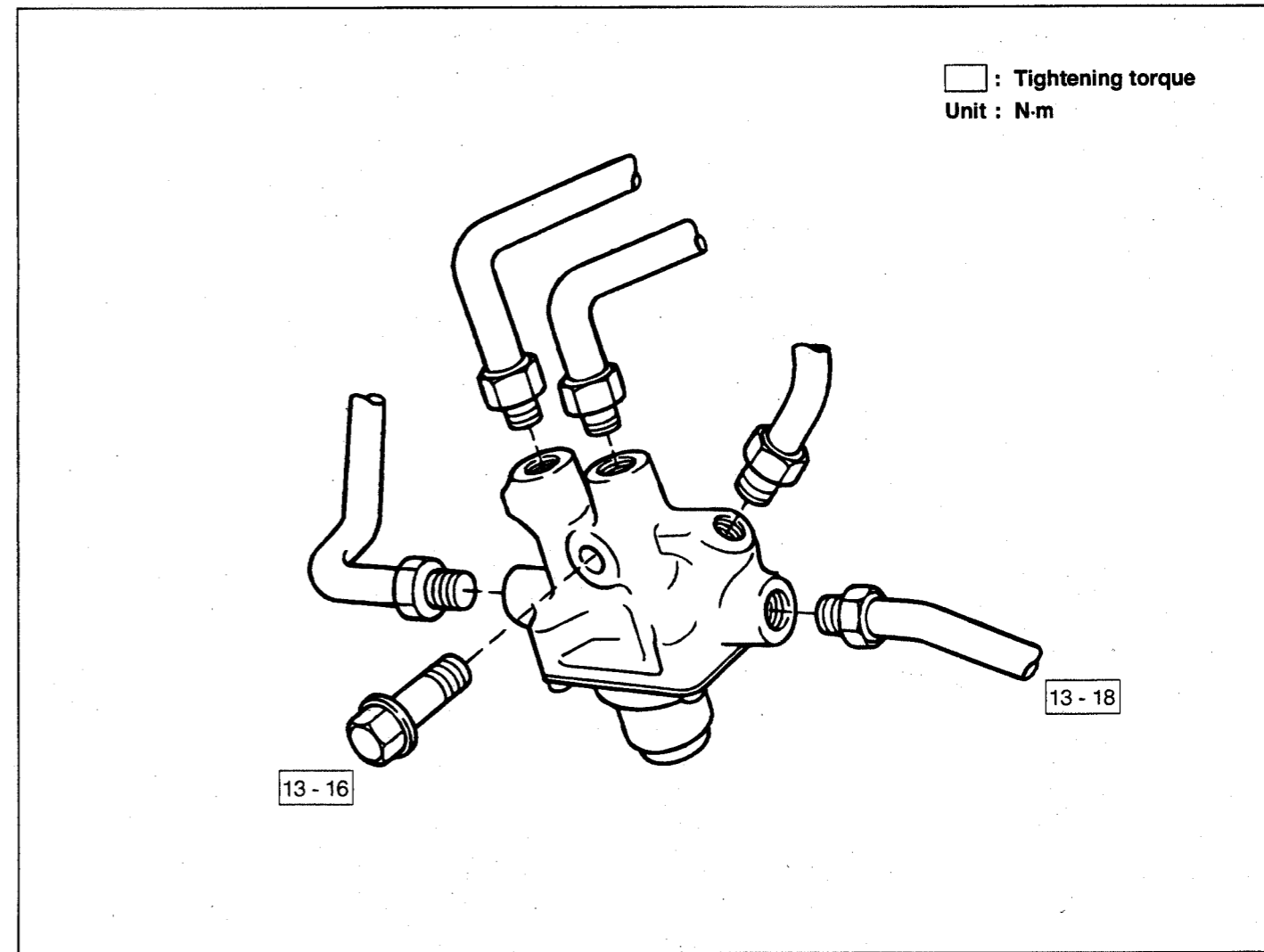

G2MA00094-00078

Replacement

1. Disconnect the brake pipes from the proportioning valve.
2. Remove the bolt from the body.

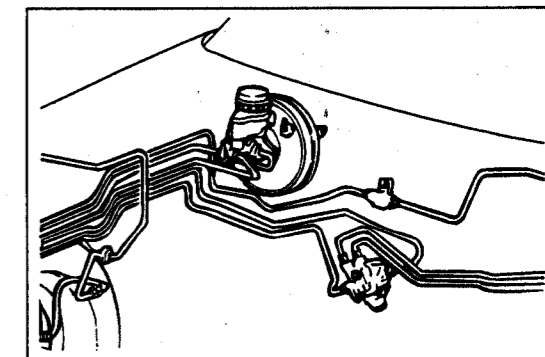

G2MA00095-00079

Installation

1. Install new proportioning valve with the bolt.  
 Tightening Torque: 13 - 15 N·m (1.3 - 1.6 kgf·m)
2. Install the brake pipes to the proportioning valve.  
 Tightening Torque: 13 - 17 N·m (1.3 - 1.8 kgf·m)
3. Perform the air bleeding for the brake system.

G2MA00096-00000

FUEL HOSE AND CHECK VALVE

COMPONENTS

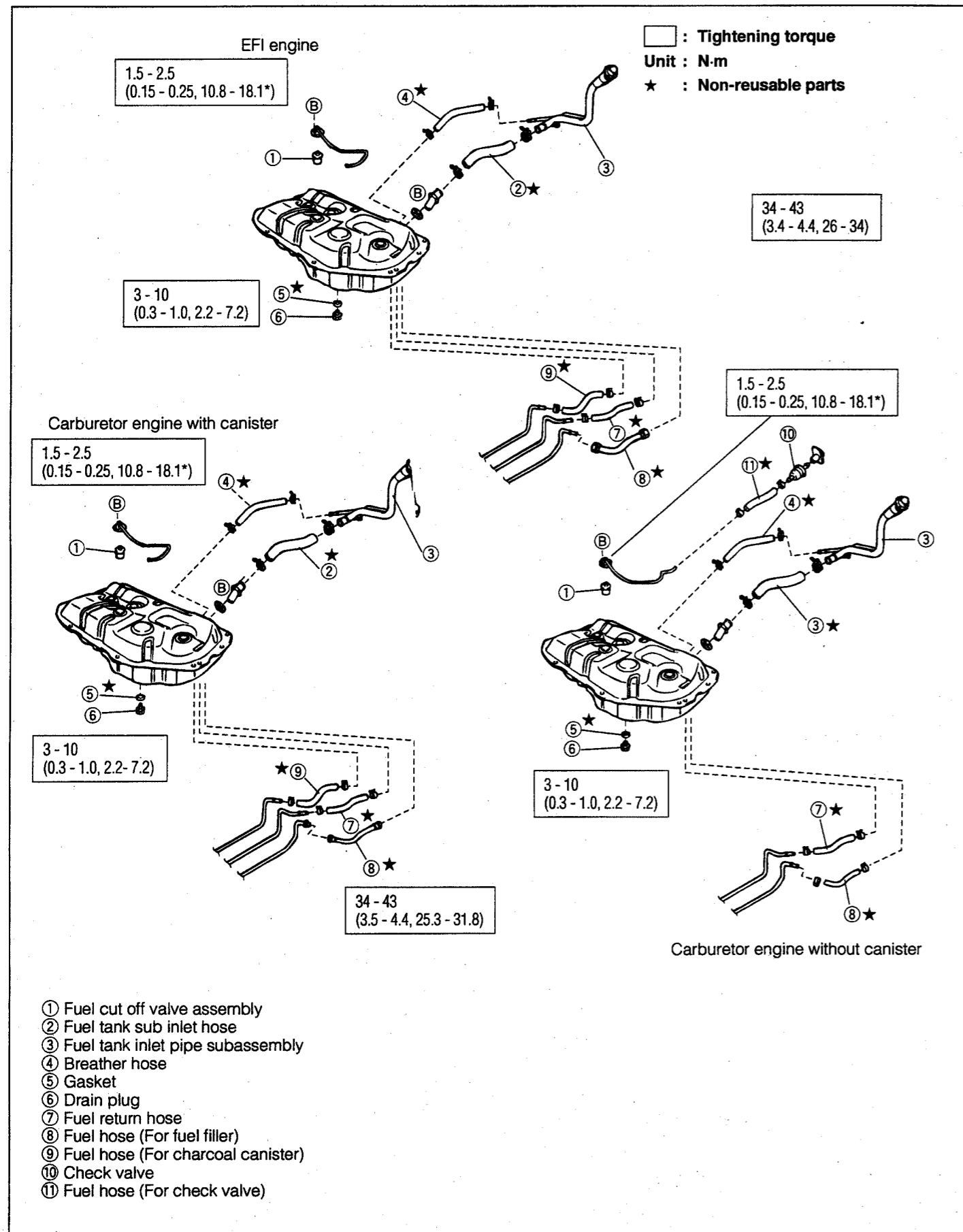

G2MA00097-00080

FUEL TANK REMOVAL

1. Jack up the vehicle and support it with safety stand.
2. Drain the fuel from the tank by removing the drain plug. After the fuel has been drained, install the drain plug with a new gasket.

Tightening Torque: 3 - 10 N·m (0.3 - 1.0 kgf·m)

3. Disconnect the negative terminal from the battery.

G2MA00098-00000

4. Disconnect the fuel sender gauge and fuel pump connector under the rear seat cushion.

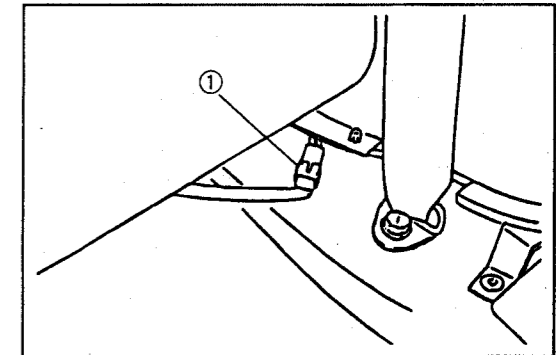

5. Remove the fuel tank inlet pipe and the breather hose.
6. Remove the check valve.

(For carburetor engine without canister)

WARNING:

- Never allow any fire to be brought near the working site.

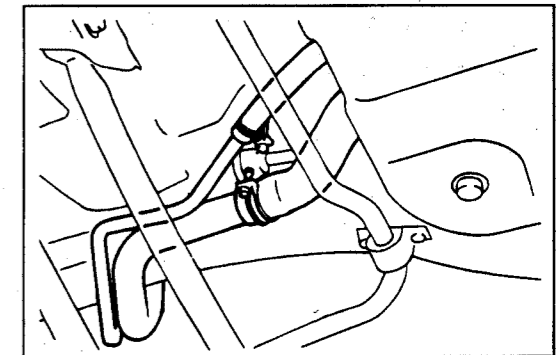

7. Remove the fuel hose for fuel filter.
8. Remove the fuel return hose.
9. Remove the fuel hose for canister.

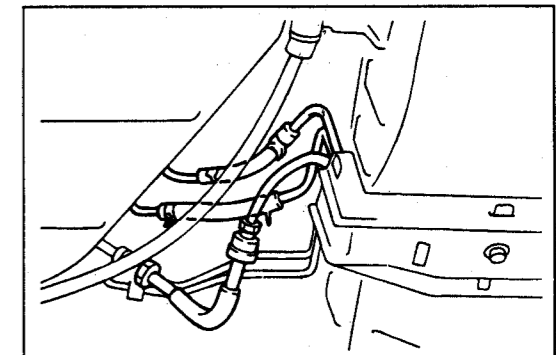

10. Remove the fuel tank by removing the attaching bolts.

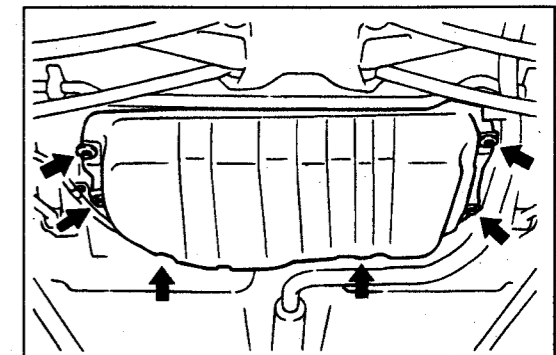

G2MA00102-00084



**FUNCTION CHECK OF CHECK VALVE**

1. Remove the fuel cut off valve, by removing the fuel tank breather pipe subassembly.

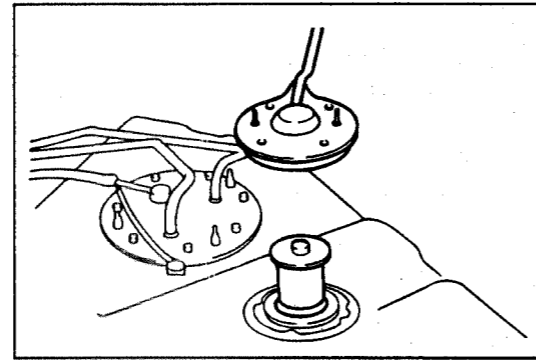

G2MA00103-00085

2. Ensure that the air continuity is present, as indicated in the illustration.

Tightening Torque: 1.2 - 1.5 N·m (0.15 - 0.25 kgf·m)

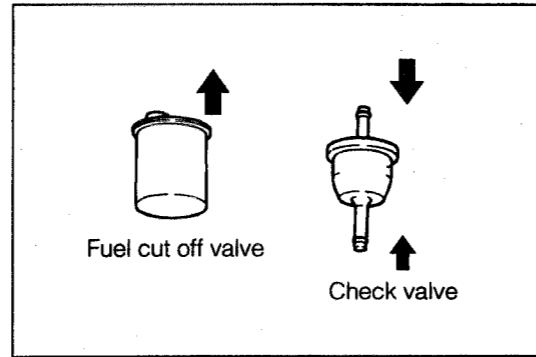

G2MA00104-00086

3. Install the fuel cut off valve, a new gasket and fuel tank breather tube subassembly.

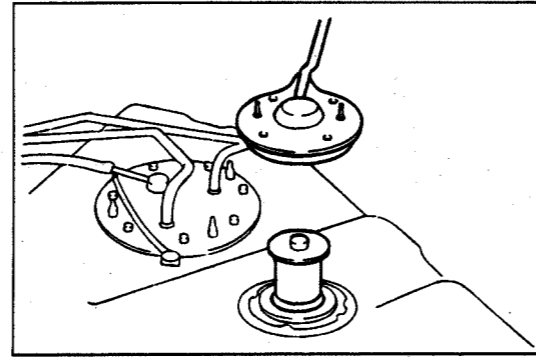

G2MA00105-00087

**FUEL TANK INSTALLATION**

Reverse the removal procedure to install the fuel tank assembly.

G2MA00106-00000

**CHASSIS GREASE & OIL**

**CONDOTION**

Visually check that the grease and oil condition is adequate on the following chassis various parts.

- Steering related parts
- Knuckle, king pin related parts
- Suspension related parts
- Door related parts
- Hood lock related parts

G2MA00107-00000

**DOOR & HOOD**

**LOCK OPERATION**

1. Check that the door lock operates properly.
2. Check that the key lock and inner lock (including child safety) operate properly.
3. Check the doors for opening/closing, alignment and tightness.

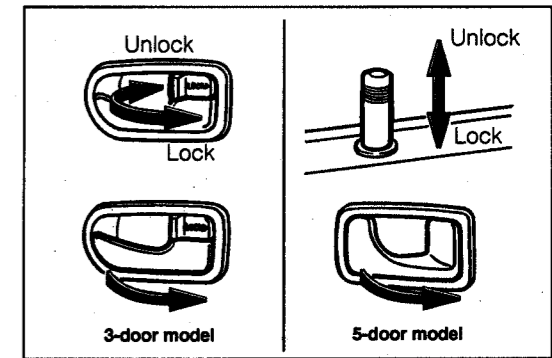

G2MA00108-00088

**DAMAGE & TIGHTNESS**

1. Check each hinge provided on the side doors and back door for looseness, moving by hand.
2. Check the hinge of the engine hood for looseness, moving by hands. Also, visually check the hinges for damage.

G2MA00109-00000

**MUFFLER AND EXHAUST PIPE**

**DAMAGE & TIGHTNESS**

1. Check that the attaching section of the exhaust pipe and muffler as well as their connecting section for looseness, using a spanner or moving them by hand.
2. Visually check the exhaust pipes and mufflers for damage and leak of exhaust gas. Also ensure that there is no possibility of interference with any other parts.

**WARNING:**

- Never perform this check when the exhaust system is hot. Be careful not to burn yourself.

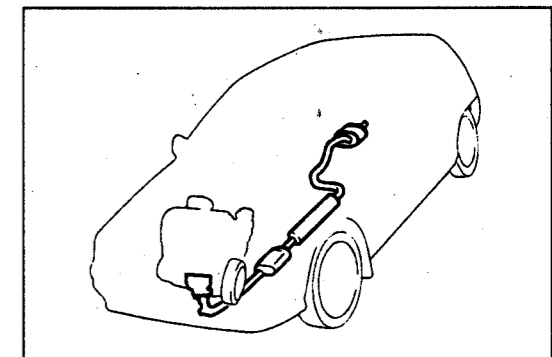

G2MA00140-00089

**FUNCTION OF MUFFLER**

Ensure that the muffler functions properly by changing the engine revolution speed.

G2MA00111-00000

**SEAT BELTS**

**OPERATION**

Visually check the seat belts for damage. Also, check that the tongue plate can be buckled properly.

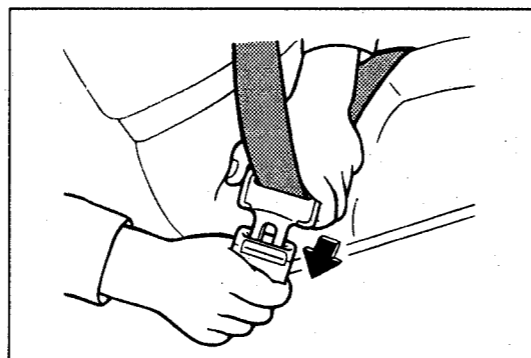

G2MA00112-00090

**TIGHTNESS**

Check the seat belt attaching bolts for tightness.  
Tightening Torque: 29 - 53 N·m (2.9 - 5.4 kgf·m)

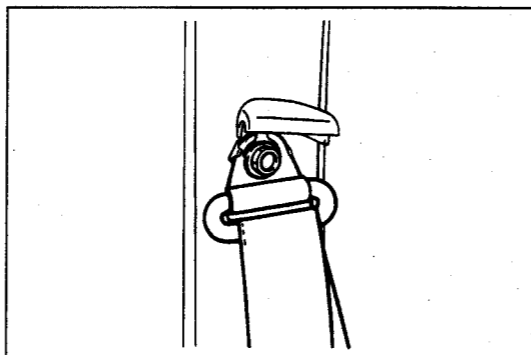

G2MA00113-00091

**BATTERY**

**CONNECTION OF TERMINAL SECTION**

Check the terminal connections for cracks, corrosion or looseness. Check the hold-down clamps for looseness.

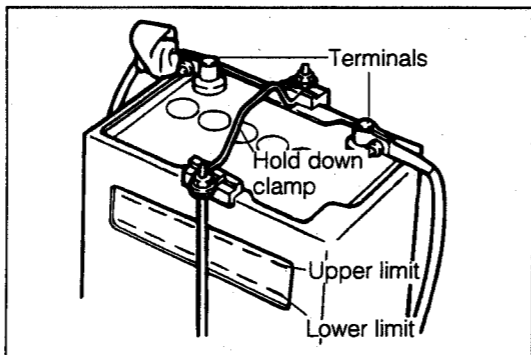

G2MA00114-00092

**SPECIFIC GRAVITY (Except for Delco Freedom battery)**

Check that the gravity should be more than 1.25 (20 °C)

**ELECTROLYTE LEVEL (Except for Delco Freedom battery)**

Check the electrolyte level, if it is between the upper and lower limits.

**NOTE:**

For Delco Freedom battery

1. It is impossible to add the electrolyte, for it is permanently sealed.
2. It is possible to check the battery condition on the Hydrometer provided in the battery.
  - Green dot is visible:  
The battery is adequately charged.
  - Dark (The green dot is invisible):  
The battery must be charged.
  - Clear or light yellow:  
Replace the battery.

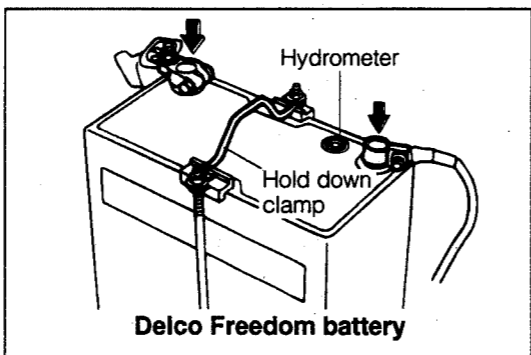

G2MA00115-00093

G2MA00116-00000

**HORN, WIPER, WINDSHIELD WASHER & DEFROSTER**

**FUNCTION**

**Horn**

1. Ensure that the horn functions properly when any position of the horn button are pushed while turning the steering wheel.
2. Check horn volume and tone.

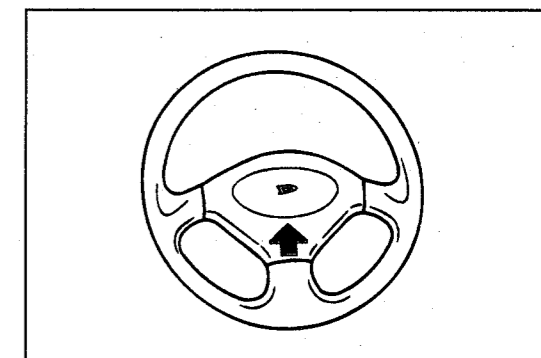

G2MA00117-00094

**Wiper switch**

1. When the wiper switch is operated with the engine switch turned to the "ON" position, ensure that the wiper operates properly at each position of "INT", "LO" and "Hi" positions.
2. When the wiper is operated, check that the wiping condition is good.
3. When the wiper switch is turned to the "OFF" position, ensure that the wiper is returned to the original position automatically.

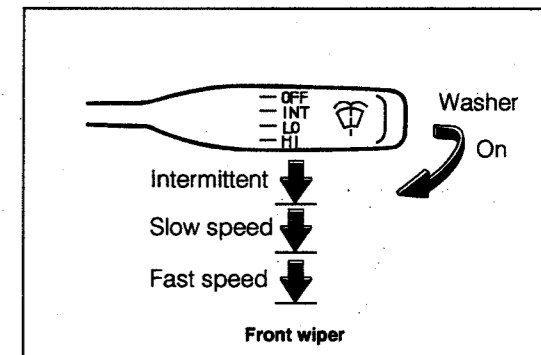

G2MA00118-00095

**Windshield washer**

Squirt the washer, then check its direction and height.

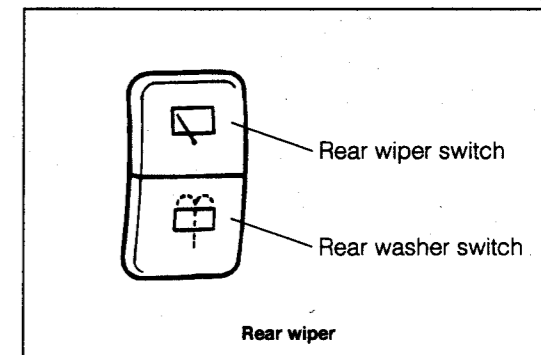

G2MA00119-00096

**Defroster**

1. When the blower fan switch is "ON" and the air outlet control lever is moved to the E position with the engine switch turned to the "ON" position, ensure that the air is directed from the defroster outlet ports.
2. Check that the air amount is changed in accordance with the operation of the blower fan switch.

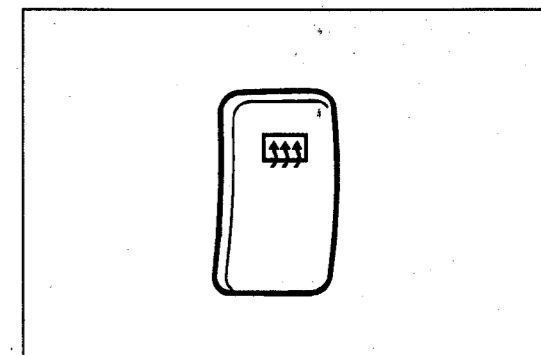

G2MA00120-00097

**LIGHTING SYSTEM**

**FUNCTION**

**Light control switch**

1. Ensure that each lamp goes on when the lever is operated.
2. Check lightness of the headlamps and the headlamp aiming.

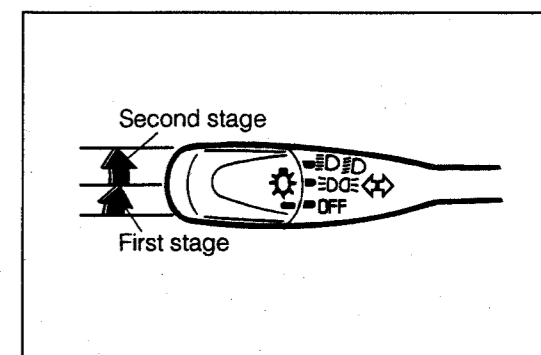

G2MA00121-00098

**Dimmer switch and passing light**

1. Check the dimmer switch and passing light for operation.
2. Ensure that the indicator lamp glows when the head-lamps are upper beam.

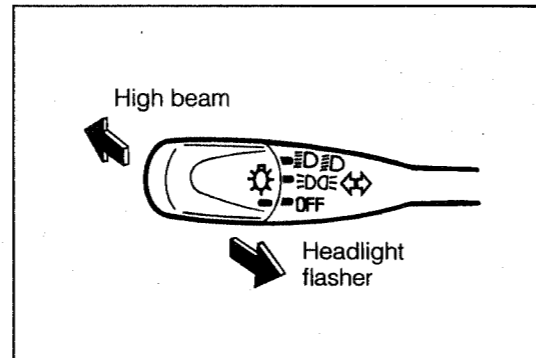

G2MA00122-00099

**Turn signal switch**

1. Ensure that the following lamps at the side where the switch is operated flash. The front, rear, side turn signal lamps and the indicator lamp.
2. Ensure that the self cancel mechanism operates properly.

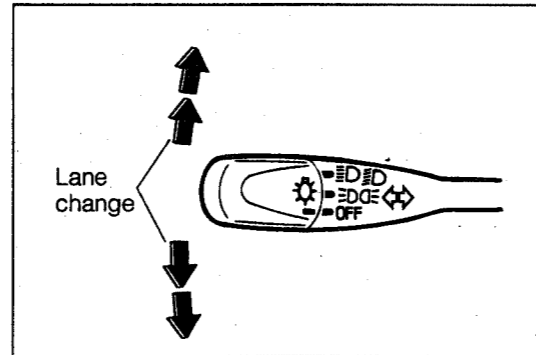

G2MA00123-00100

**Hazard warning signal switch**

Ensure that the turn signal lamps and the signal indicator lamps flash when the switch is operated.

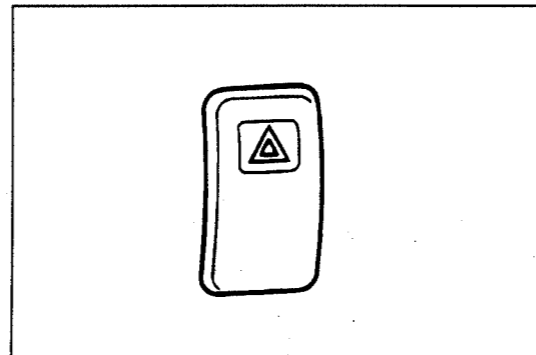

G2MA00124-00101

**Room lamp**

1. Ensure that the room lamp always glows when the switch is at the "ON" position.
2. Move the switch to the "DOOR" position, then ensure that the room lamp glows only when the side door is opened.

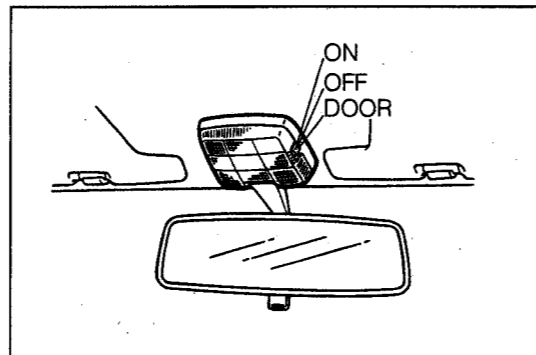

G2MA00125-00102

**Stop lamp**

When the brake pedal is depressed, ensure that the stop lamp goes on. Also check that the stop lamp goes out when the brake pedal is released.

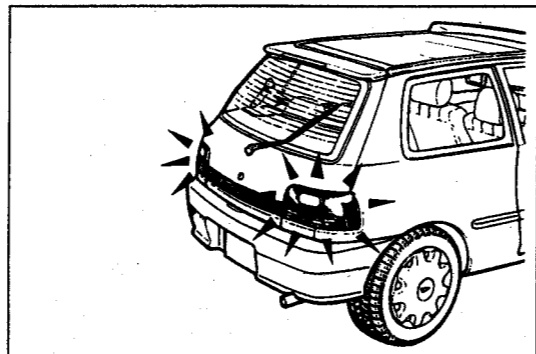

G2MA00126-00103

**Back-up lamp**

When the shift lever is shifted into the reverse position with the engine switch turned to the "ON" position, ensure that the back-up lamp goes on.

**METER & GAUGE**

**FUNCTION**

**Speedometer**

1. Check that the pointer complies smoothly in accordance with the vehicle speed.
2. Check that the pointer does not fluctuate remarkably.

**Tachometer**

Check that the pointer complies smoothly in accordance with the engine revolution speed.

**Water temperature gauge**

Check that the pointer is at the starting point when the engine is cold and it is moved in accordance with warming-up the engine.

**Fuel gauge**

Ensure that the pointer always indicates the fuel amount even when the engine switch is turned to the "OFF" position.

**Warning light**

Ensure that the warning lights glow with the engine switch turned to the "ON" position. And go out when the engine has been started and the parking brake lever is released.

**WIRE HARNESS**

Check the wire harness and clamps for damage.

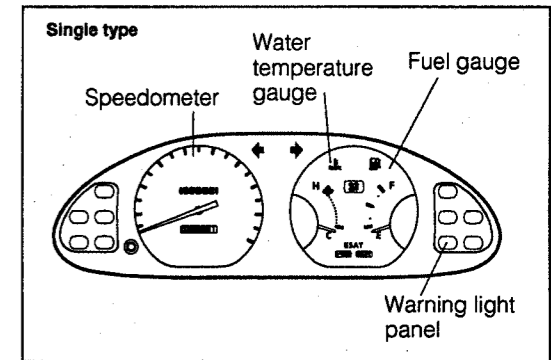

G2MA00127-00104

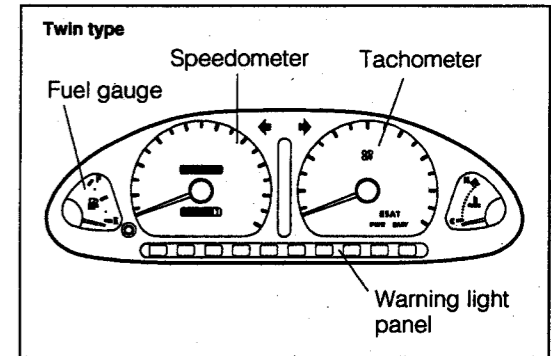

G2MA00128-00105

G2MA00129-00000

G2MA00130-00000

**CLUTCH**

**FREE PLAY**

1. Lightly depress the clutch pedal by hand, until you feel resistance. Then, measure the free travel.  
Specified Clutch Pedal Free Travel: 15 - 30 mm

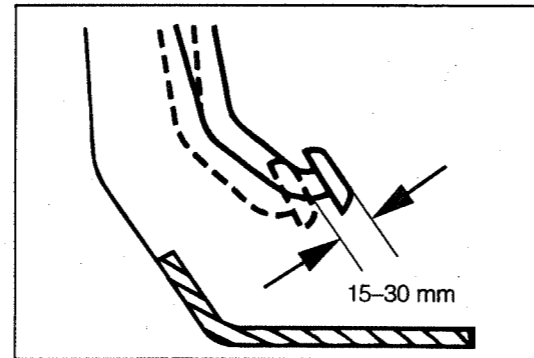

G2MA00131-00106

2. If the free travel does not conform to the specification, turn the adjusting ring of the clutch cable so as to conform to the specification.

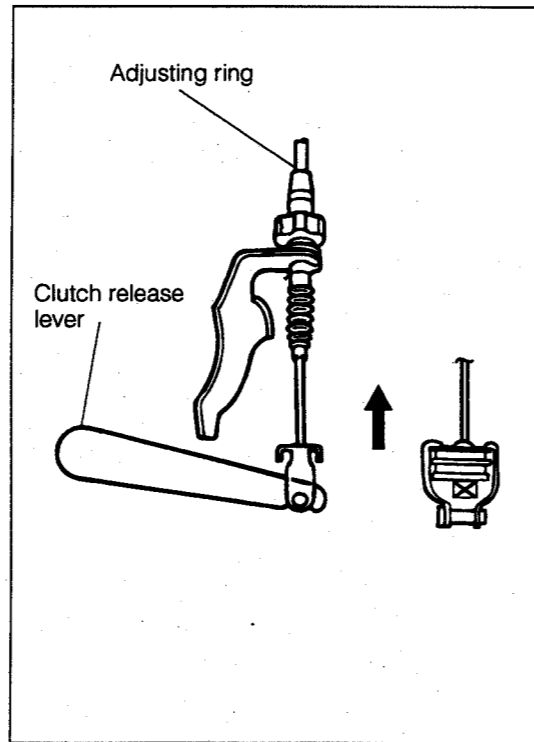

G2MA00132-00107

**RESERVE TRAVEL**

1. Start the engine.
2. When the clutch is completely disengaged, ensure that the clearance between the clutch pedal and the dash panel conforms to the specification.  
Specified Reserve Travel: 25 mm or more

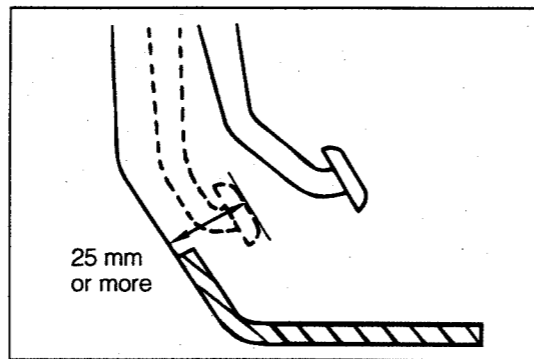

G2MA00133-00108

**OPERATION**

1. While the engine is running at idle speed, depress the clutch pedal. Ensure that no abnormal noise is emitted and the gear shift can be made smoothly into the first gear or the reverse position.
2. Move off the vehicle while releasing the clutch pedal gradually. Ensure that the vehicle exhibits no slippage and that the clutch engagement is smooth.

G2MA00134-00000

**MANUAL TRANSMISSION**

**OIL LEVEL**

1. Park the vehicle on a level road and apply the parking brake.
2. Turn the ignition switch OFF.
3. Remove the filler plug and check to see if the transmission oil level is in the limits.
4. Reinstall the filler plug with new gasket after checking.  
Tightening Torque: 30 - 49 N·m (3.0 - 5.0 kgf·m)

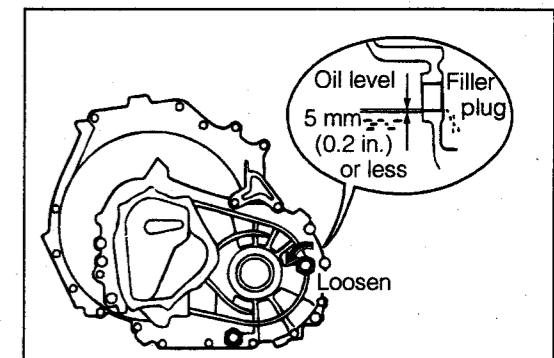

G2MA00135-00109

**OIL LEAKAGE**

Inspect the transmission for oil leakage.

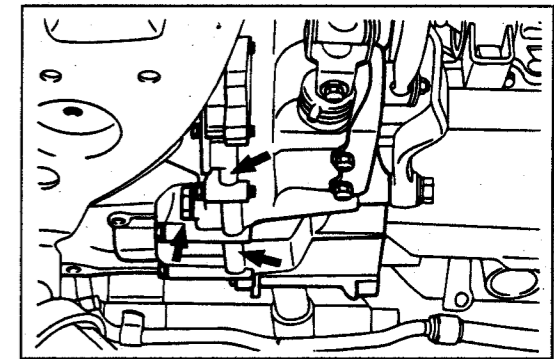

G2MA00136-00110

**OIL CHANGE**

1. Remove the drain plug and filler plug. Drain the transmission oil.
2. Reinstall the drain plug with new gasket.  
Tightening Torque: 30 - 49 N·m (3.0 - 5.0 kgf·m)
3. Replenish the transmission oil, until it begins to overflow from the filler hole.  
Manual Transmission Oil  
Grade: API GL-3  
Viscosity: SAE 75W-85 or 75W-90  
Capacity: 2.25 liters
4. Reinstall the filler plug with new gasket.  
Tightening Torque: 30 - 49 N·m (3.0 - 5.0 kgf·m)

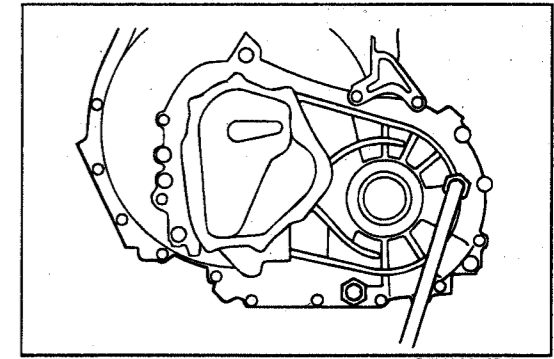

G2MA00137-00111

G2MA00138-00000

**RATTLE OF OPERATION MECHANISM**

1. Move the shift lever to the neutral position as well as to each gear position.
2. Check that the shift lever has a proper play and the gear engagement takes place smoothly when shifted. Also, check that shift lever moves smoothly.

G2MA00139-00000

**DRIVE SHAFT**

**JOINT DUST BOOT**

1. Inspect that the dust boot is free from damage or cracks.
2. Inspect that the dust boot band is secured in position.

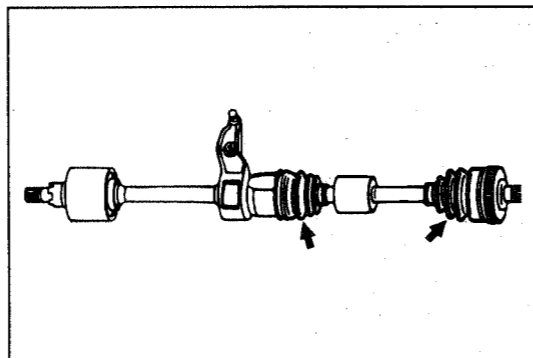

G2MA00140-00112

**CONNECTING SECTION**

1. Check to see if any looseness is present at the attaching nut of the drive shaft at the knuckle side.
2. Check that the cotter pin is not missing.

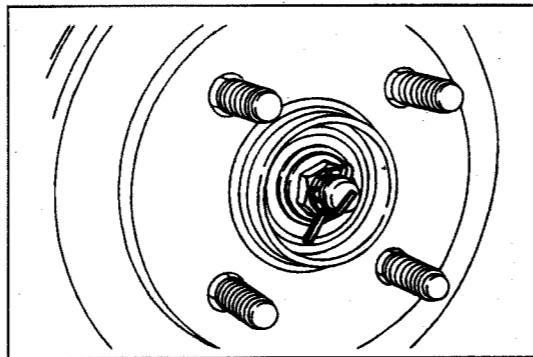

G2MA00141-00035

**JOINT SECTIONS**

1. Move the drive shaft by hand in an up-and-down direction as well as in a right-and-left direction.
2. Inspect that the joint section exhibits no excessive rattle.

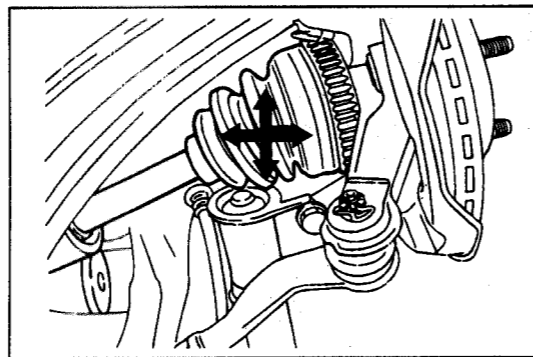

G2MA00142-00114

**SPLINE SECTION**

1. Check the spline section for excessive play by turning the drive shaft by hand.

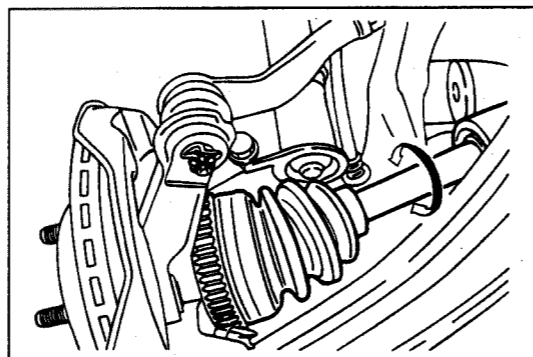

G2MA00143-00115

**TIRE**

**CLACKS AND DAMAGE**

Inspect the tread section and side wall section for cracks and damage.

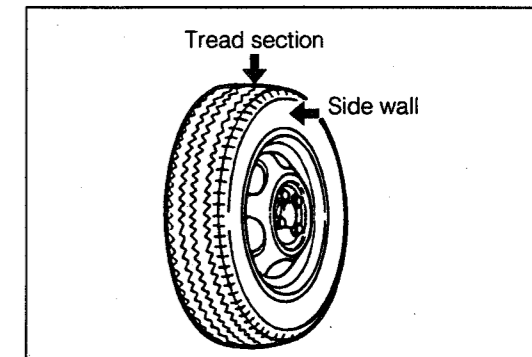

G2MA00144-00116

**OBJECTS CAUGHT IN THE TIRE PATTERN**

Ensure that no nail, metal chip, gravel or other foreign matters lodge at the grooves of each tire, or none of them sticks into the tire.

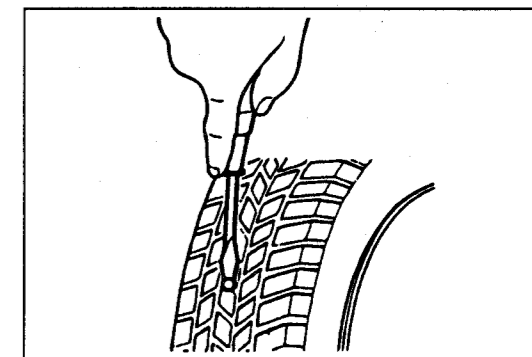

G2MA00145-00117

**PRESSURE**

1. Check to see if the tire air pressure conforms to the specification, using a tire gauge.
2. Ensure that no air leaks from the tire valve and that the valve cap is attached.

**NOTE:**

- For the specified air inflation pressure, see the caution plate attached to the vehicle. Be very careful not to over inflate the tires excessively.

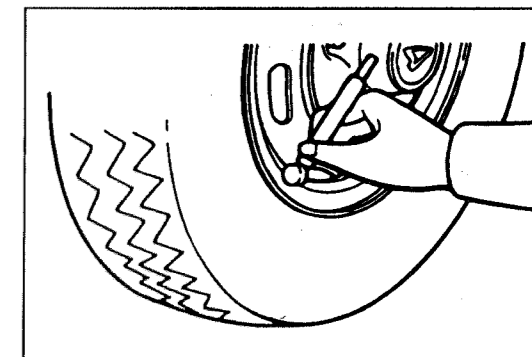

G2MA00146-00118

**WEAR**

Inspect the tread section for wear. Ensure that the groove depth is at least 1.6 mm.

**NOTE:**

- Care must be exercised as to the wear indicator mark. (When the remaining groove depth is reduced to less than 1.6 mm, the wear indicator mark will become visible.)
- Inspect the tire for uneven wear, ridge and other abnormal wear.
- If the tires exhibit an uneven wear pattern, check the wheel balancing and front wheel alignment.

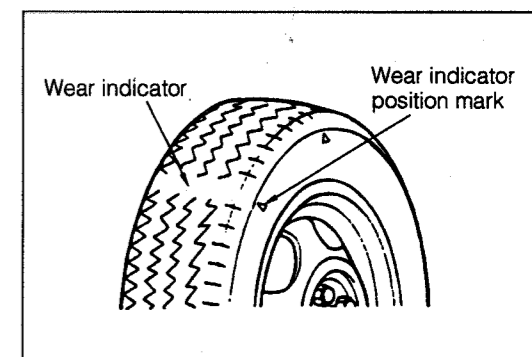

G2MA00147-00119

**ROTATION**

1. Rotate the tires in the order shown in the illustration.
  - Note 1 Vehicle with 4 steel wheels and one steel spare wheel or 4 aluminum wheels and one aluminum spare wheel.
  - Note 2 Vehicle with compact spare wheel or 4 aluminum wheels and one steel spare wheel.
  - Note 3 Vehicle with 175/60 R14 tires. (Original factory-installed tires)

Tire Rotation Interval: every 10,000 km (6000 miles)

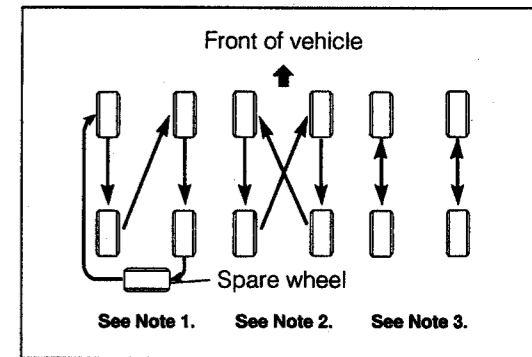

G2MA00148-00120

2. Adjust the tire air pressure after rotation.

**WHEEL**

**WHEEL DISC**

Rim and wheel disc  
 Inspection of damage  
 Inspect that the rim and wheel disc exhibit no corrosion, deformation, cracks nor runout.

Reference

Runout Limit:

Not to exceed 3 mm

(Measured at outer peripheral section of wheel)

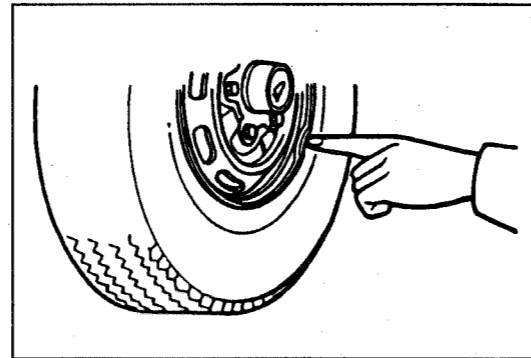

G2MA00149-00121

**WHEEL HUB NUTS**

Inspection of looseness  
 Inspect the wheel hub nuts and bolts for looseness, using a wheel nut wrench.

Tightening Torque: 90 - 120 N·m (9.0 - 12.0 kgf·m)

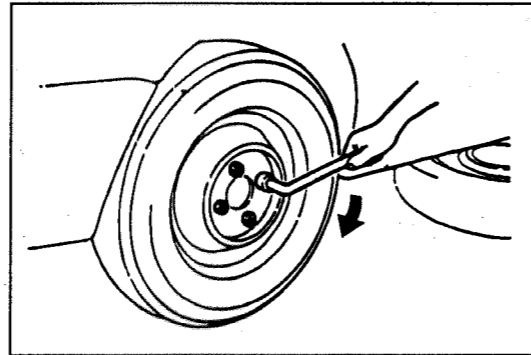

G2MA00150-00122

**WHEEL BEARING**

**RATTLE**

1. Move the tire up and down while holding it at the top and bottom sections by your hands. Ensure that the rear wheel bearing exhibits no excessive play.
2. Ensure that no abnormal sound is emitted when the wheel is rotated.
3. Remove the rear wheel bearing and inspect the bearing, etc. for wear and damage, as required.
4. If excessive rattle is found, perform the check while the brake pedal is being depressed. If the rattle disappears, it indicates that the wheel bearing is loose. If the rattle persists, it indicates that the knuckle section or other suspension parts are loose.

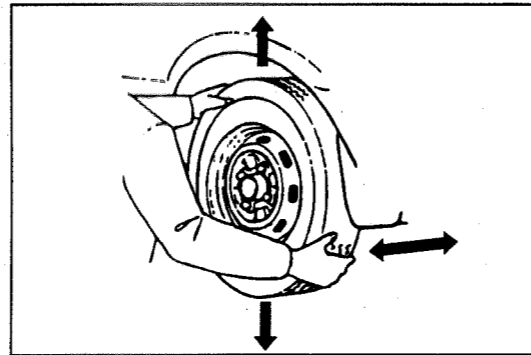

G2MA00151-00123

G2MA00152-00000

**STEERING BALL JOINT DUST BOOT**

**DAMAGE**

Inspect the dust boot of tie rod end ball joint for crack or damage.

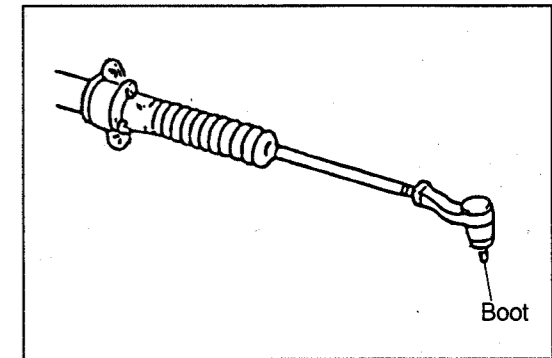

G2MA00153-00124

**GEAR BOX**

**LEAKAGE**

1. Inspect the power steering device for fluid leakage.
2. Inspect the tightness of power steering device.

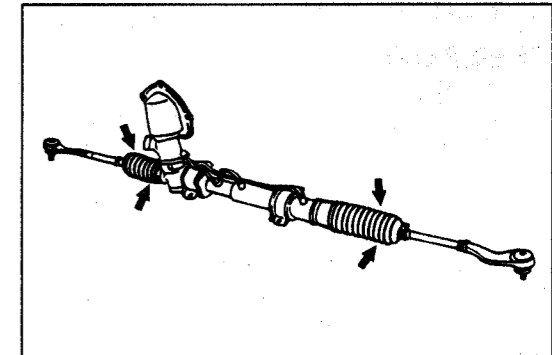

G2MA00154-00125

**TIGHTNESS**

Inspect the bolts of the gear box for looseness.  
 Tightening Torque: 32 - 47 N·m (3.2 - 4.8 kgf·m)

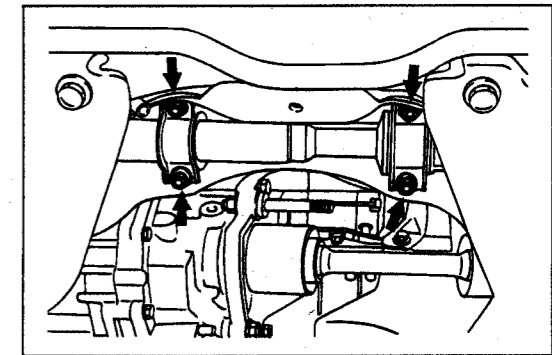

G2MA00155-00126

**KNUCKLE**

**RATTLE OF LINKAGE**

Inspect the linkage of the knuckle for rattle.

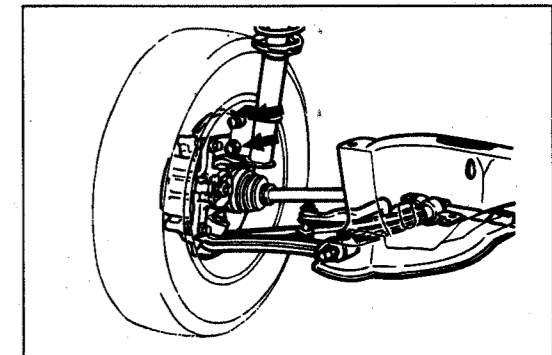

G2MA00156-00127

**TIE ROD AND ARM**

**DAMAGE**

Inspect the tie rod end, lock nuts and arm for damage.

**TIGHTNESS**

Inspect the nuts of the tie rod for looseness.  
 Tightening Torque: 26 - 38 N·m (2.7 - 3.9 kgf·m)

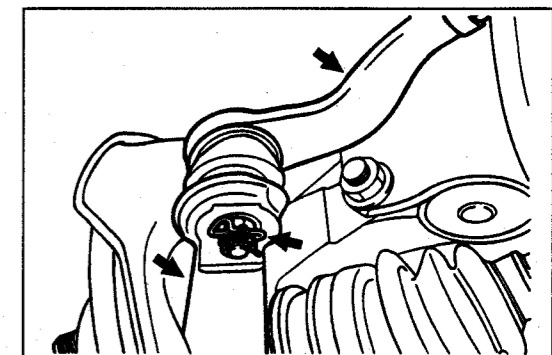

G2MA00157-00128

**RATTLE**

Inspect the tie rod end, lock nuts and arm for rattle.

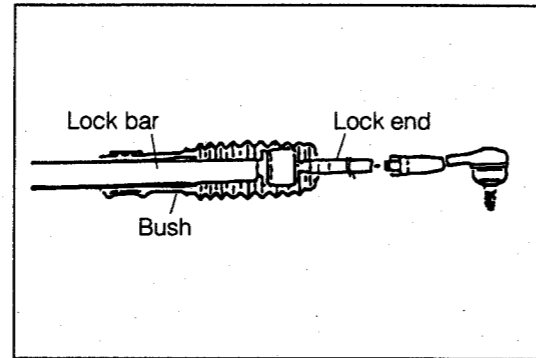

G2MA00158-00129

**STEERING WHEEL**

**FREE PLAY**

1. Set the vehicle in a straight-ahead condition.
  2. Inspect the steering wheel play by turning it lightly with your fingers.
- Specified Value: 10 mm Max.

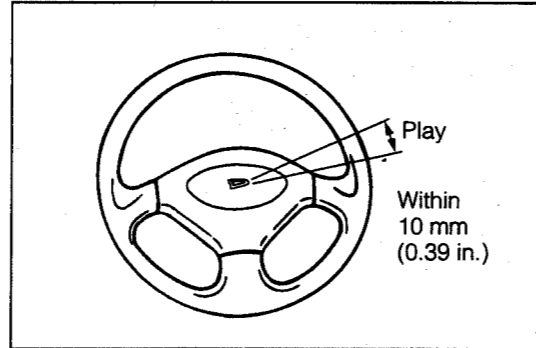

G2MA00159-00130

**OPERATION**

Take road test. Ensure that the steering wheel exhibits no excessive shimmy motion.

**RATTLE**

Hold the steering wheel by your hands. Ensure that the steering wheel exhibits no excessive looseness or play by moving it in an up-&-down direction, a right-&-left direction as well as in a fore-&-aft direction.

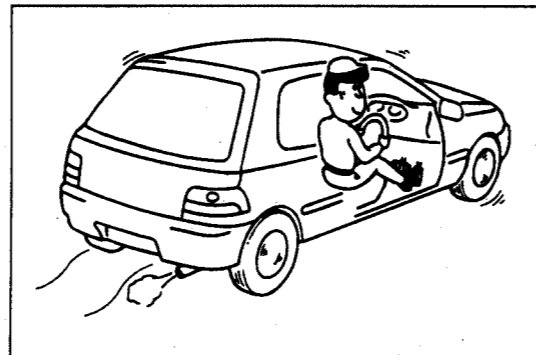

G2MA00160-00131

**TIGHTNESS**

Inspect the attaching sections for tightness or damage.

**Tightening Torque**

- Steering Wheel / Steering Main Shaft: 28 - 41 N·m (2.8 - 4.2 kgf-m)
- Steering Main Shaft / Universal Joint: 25 - 34 N·m (2.5 - 3.5 kgf-m)
- Universal Joint / Steering Pinion: 25 - 34 N·m (2.5 - 3.5 kgf-m)

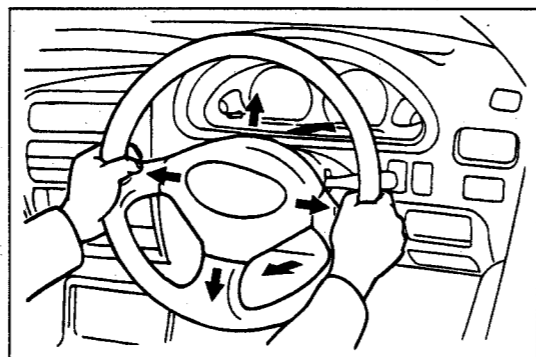

G2MA00161-00132

**WHEEL ALIGNMENT**

**SIDE SLIP TEST**

Check the sideslip, using a sideslip tester.  
Specified Value: 0 ± 3 mm per 1 m

G2MA00162-00000

**TURNING ANGLE**

1. Measure the wheel turning angle, using a turning radius gauge.  
Specified Value: Inner side: 39° 45' ± 2°  
Outer side: 34° 30' ± 2°
2. If the wheel turning angle differs between the right and left sides, correct the turning angle.

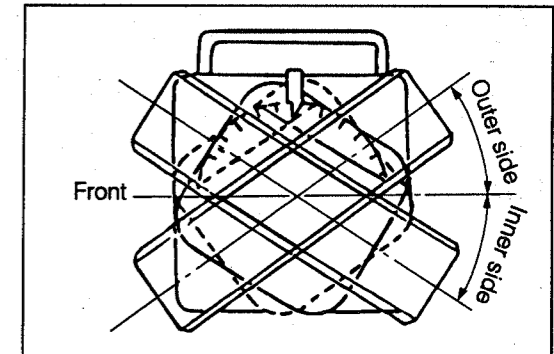

G2MA00163-00133

**CORRECTION OF WHEEL TURNING ANGLE**

- (1) Loosen the lock nuts of the tie rod ends.
- (2) Make the length (a) indicated in the illustration, equal between the right and left sides length.

**NOTE:**

- Make sure that the boot is not twisted during this correction.
  - Make sure that the tie rods at the right and left sides are turned by the same amount.
- Tightening Torque: 38 - 56 N·m (3.9 - 5.7 kgf-m)

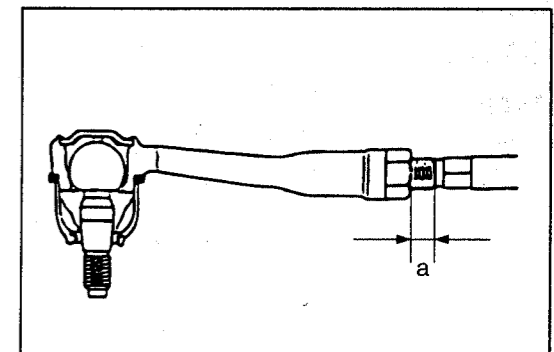

G2MA00164-00134

**SUSPENSION & LINKAGE**

**DAMAGE**

Visually inspect each coil spring for breakage and cracks.

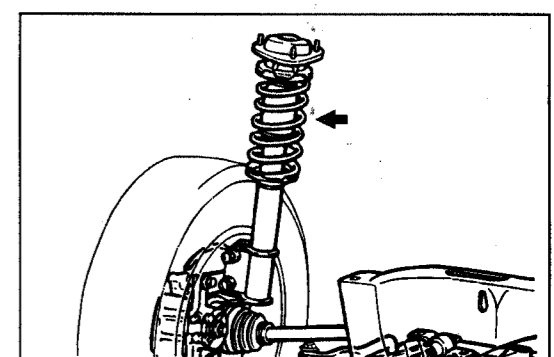

G2MA00165-00135

**RATTLE**

Check the arm connecting section for rattle by rocking it by hand.

**TIGHTNESS**

Inspect the attaching sections for tightness.

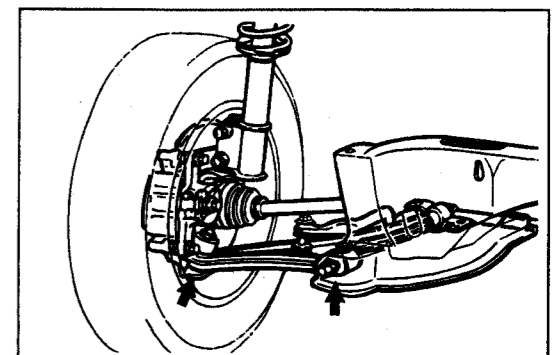

G2MA00166-00136

# MA-46

## SHOCK ABSORBER

### DAMAGE AND OIL LEAKAGE

Visually inspect each shock absorber for damage and oil leakage.

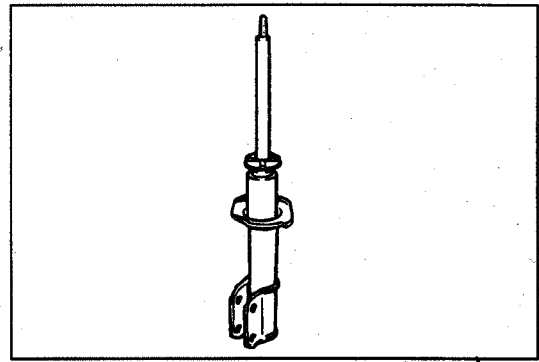

G2MA00167-00137

### RATTLE

Check each shock absorber installation section for excessive play by rocking it by hand.

Check the installation section for looseness with a spanner.

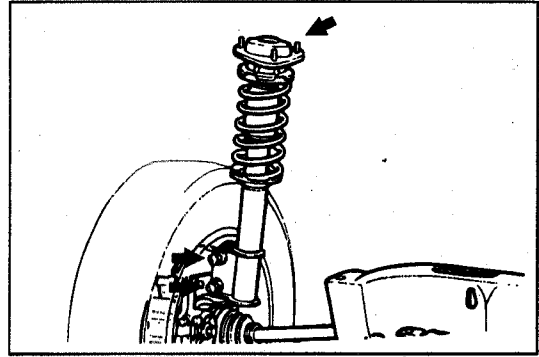

G2MA00168-00138

### FUNCTION

Rock the vehicle in up-&-down direction. Ensure that the vehicle emits no abnormal noise.

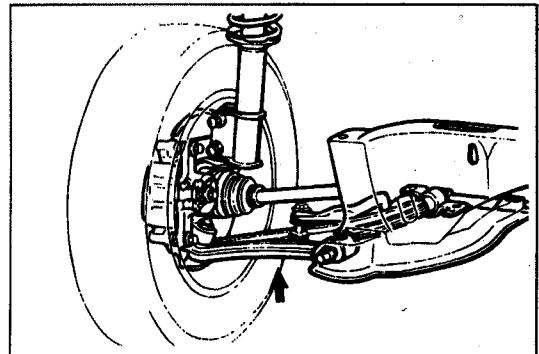

G2MA00169-00139

## SUSPENSION ARM, CONTROL ARM & DUST COVER

### DAMAGE

Visually inspect the suspension arms and strut rod for damage.